

Victorian Electricity Distributors

# Service & Installation Rules 2014

Incorporating Amendment 1 - April 2017 (A1)

Incorporating Amendment 2 - July 2019 (A2)

Incorporating Amendment 3 - October 2022 (A3)

These Service & Installation Rules form the following Distributors  
“Reasonable Technical Requirements” for the connection of  
electrical installations to their Victorian electricity networks:

- AusNet Services
- CitiPower Pty
- Jemena Electricity Networks
- Powercor Australia Ltd
- United Energy



**AusNet**

  
**CITIPOWER**

  
**Jemena**

  
**Powercor**  
AUSTRALIA

**united  
energy** 



## Acknowledgment

The Victorian Service and Installation Rules Management Committee wishes to thank the following organisations for their valuable assistance in the preparation of these rules.

Energy Safe Victoria (ESV)

National Electrical and Communications Association (NECA)

Institute of Electrical Inspectors Australia (IEI)

Master Electricians Australia (MEA)

Clean Energy Council (CEC)

A2 |

## Frequently Asked Questions

The 3rd Amendment to the Victorian Service & Installation Rules (VSIR's) was released in October 2022. Frequently Asked Questions (FAQ's) and answers have been developed by the VSIR Management Committee to explain some of the issues which have been raised by users of the Rules.

These are available on the VSIR website, [www.victoriansir.org.au](http://www.victoriansir.org.au)

The FAQ's are noted throughout the document by **FAQ**

## Foreword

The Service & Installation Rules, 2014, have been developed by the Victorian Electricity Distributors Service and Installation Rules Management Committee and supersede the 2005 edition.

A2 |

This edition of the Rules will commence operation on 1 January 2014 and apply to all connections to the electricity supply networks operated by the Victorian Electricity Distributors, namely CitiPower, Jemena Electricity Networks, Powercor Australia Ltd, AusNet Services and United Energy.

The Rules form the major part of Victorian Electricity Distributors' "reasonable technical requirements" as referred to in the Electricity Distribution Code. The Electricity Distribution Code is applied under the Electricity Industry Act 2000 (Vic) and is administered by the Essential Services Commission Victoria.

The Rules have been subject to extensive industry consultation during their development and offer users with industry agreed specifications intended to assist Distributors, Retailers, customers and customers' agents to meet their regulatory and electricity supply obligations. The Rules lessen the need to reference the complex, extensive and expanding range of regulations and documentation relating to connection of installations to Victorian electricity networks.

A2 |

All installations connected, or to be connected, to the Victorian Electricity Distribution networks shall comply with the Rules as a condition to acquiring and maintaining an electricity supply.

A2 |

The Rules may not cover all circumstances. These may include unusual connections, inadvertent omissions or changes to legislation and codes. The Victorian Electricity Distributors SIR Management Committee does not accept responsibility where this occurs. The relevant Victorian Electricity Distributor shall be consulted in these circumstances.

*Peter Allan*  
**Chairman**  
**Victorian Service and Installation Rules**  
**Management Committee**

# Section 1

## General

## 1.1 Document Contents Summary

A2

<b>Section 1</b>	<b>General</b>	<b>Page</b>
1.1	Document Contents Summary	1-2
1.2	References	1-5
1.3	Definitions	1-6
1.4	Abbreviations	1-10
1.5	Symbols	1-12
<b>Section 2</b>	<b>Introduction</b>	
2.1	Disclaimer	2-3
2.2	Copyright	2-3
2.3	Innovation	2-3
2.4	Objective	2-3
2.5	Users	2-3
2.6	Publication and Revision	2-4
2.7	SIR Management Committee Contact	2-5
2.8	Dispute Resolution	2-5
2.9	Scope	2-5
2.10	Application & Application Responsibilities	2-5
2.11	Failure to Comply with These Rules	2-5
2.12	Exceptional Circumstances	2-6
2.13	Offences	2-6
2.14	Necessity for Employing a Licensed Person	2-6
2.15	Basic Industry Relationship	2-7
<b>Section 3</b>	<b>Distribution Areas and Contact Details</b>	
	Victorian Distribution Companies	3-3
	CitiPower	3-4
	Jemena Electricity Network	3-5
	Powercor Australia	3-6
	AusNet Services	3-7
	United Energy	3-8
<b>Section 4</b>	<b>Supply Application, Connection &amp; Disconnection</b>	
4.1	Conditions of Supply	4-3
4.2	Negotiations for Obtaining / Altering an Electricity Supply and Warning against Premature Expenditure	4-3
4.3	Typical Connection Process	4-4
4.4	Application for Supply Availability	4-4
4.5	Notification of Electrical Work	4-5
4.6	Charges	4-7

A1

	<b>Section 4</b>	<b>Supply Application, Connection &amp; Disconnection</b>	<b>Page</b>
A3	Form	Electrical Work Request (EWR)	4-9
	Form	Field Works Order	4-10
	Form	Application for Abolishment of Electrical Supply	4-11
	Form	Deleted	4-12
	<b>Section 5</b>	<b>General Rules</b>	
	5.1	Safety	5-3
	5.2	Compliance with Regulations, Codes of Practices and these Rules	5-5
	5.3	Equipment Acceptance	5-6
	5.4	Labelling	5-6
	5.5	Access to Distributors' Equipment	5-7
	5.6	Sealing and Locking	5-7
	5.7	Private Electric Lines on Public Land	5-9
	5.8	Multiple Occupancy Buildings and Subdivisions (General)	5-12
	<b>Section 6</b>	<b>Supply Types, Use and Protection</b>	
A2	6.1	Network Supply	6-7
	6.2	Point of Supply	6-8
	6.3	Consumer's Terminals	6-10
	6.4	Supply Arrangement Diagrams	6-11
	6.5	Supply Use Obligations	6-11
	6.6	Type of Supply and Load	6-14
	6.7	Supply Capacity (Maximum Demand Limitation)	6-15
	6.8	Installation & Supply Protection	6-16
	6.9	Sources of Alternative Supply	6-22
	<b>Section 7</b>	<b>Connecting to the Low Voltage (LV) Network</b>	
A2	7.1	Distributor's LV Network/Electrical Installation Connection	7-6
	7.2	Service Pits	7-8
	7.3	Underground Service Cables	7-10
	7.4	Overhead Services	7-16
	7.5	Un-metered Consumer's Mains & Sub Mains	7-31
	7.6	Builder's Supply in a Permanent Position	7-43
	7.7	Builder's Supply Pole in a Non-Permanent Position	7-44
	7.8	Equipment other than Consumer's Mains on a Distributor's Pole	7-45
	7.9	Electrical Installations on Public Land	7-46
	7.10	Multiple Occupancy Buildings and Subdivisions (Supply Arrangements)	7-46

<b>Section 8</b>	<b>Low Voltage Metering</b>	<b>Page</b>
8.1	Scope	8-6
8.2	Tariffs & Metering	8-6
8.3	Metering Obligations	8-6
8.4	Metering Facilities	8-7
8.5	Access	8-13
8.6	Location	8-14
8.7	Protection against Damage to and Interference with Metering Equipment, and Injury to Persons	8-16
8.8	Metering Equipment - Limits of Operation	8-16
8.9	Direct Connected Metering	8-17
8.10	Specific Situation Requirements	8-21
8.11	LV Current Transformer Metering	8-56
8.12	Metering Communications Equipment	8-70
<b>Section 9 - High Voltage Electrical Installations</b>		
9.1	Scope	9-4
9.2	Contractual Arrangements	9-4
9.3	Systems of Supply	9-4
9.4	Preliminary Information	9-5
9.5	Installation Design	9-5
9.6	Conversion from Low Voltage to High Voltage Supply	9-5
9.7	General Design	9-6
9.8	Protection	9-8
9.9	Insulation Co-ordination	9-8
9.10	Short Time Withstand Current	9-8
9.11	Earthing	9-10
9.12	Distributor's Acceptance Requirements	9-11
9.13	Metering	9-11
9.14	Testing and Commissioning	9-19
9.15	Customer's HV Installation Operation and Maintenance	9-19
<b>Appendix A Considerations for High Voltage Installations</b>		

A2



## 1.2 References

The following list of reference documents and organisations have been compiled for information purposes only. The documents and organisations referred to within the table are considered current at the time of publication of these rules. As these references are subject to change, it is the users' responsibility to confirm the particular organisations or documents referenced are current.

### Acts include:

- Electricity Industry Act 2000
- Electricity Safety Act 1998
- Essential Services Commission Act 2001
- National Electricity (Victoria) Act 2005
- Occupational Health & Safety Act 2004
- Trade Practices Act 1974 (Cth)
- Owners Corporation Act 2006

### Regulations include:

- Electricity Safety:
- (General) Regulations
  - (Management) Regulations
  - (Electric Line Clearance) Regulations
  - (Bushfire Mitigation) Regulations
  - (Cathodic Protection) Regulations

### Orders and licenses provided by the Regulators under the Acts include:

- Orders in Council made under the Acts
- Licences issued to Distributors and Retailers by the ESC under the Electricity Industry Act

### Statements, Codes and Guidelines published by Regulators under the Acts include:

- National Electricity Rules
- Electricity Distribution Code
- Electricity System Code
- Electricity Retail Code
- Electricity Customer Metering Code
- Public Lighting Code
- VESI Metrology Procedure
- Guidelines published by the ESC
- Codes of Practice and Guidelines published by ESV
- No Go Zone (Framework for Undertaking Work Near Overhead and Underground Assets)

#### Codes of Practice:

- for Safe Electrical Work Low Voltage Electrical Installations

### Other references include:

- Distribution Company's List of Approved Charges
- Specification for Indoor Substation on Customers Property
- Guide to the Permanent Earthing of Distribution System Assets
- Standards Australia
- Codes of Practice:
  - for Overhead Power and Telecommunications In-span Crossings
  - of Electrical Safety for Work on or Near High Voltage Electrical Apparatus (The Blue Book)
  - Shared Use of Poles Code
  - for Low Voltage Fuse Removal and Reinsertion
  - Electrical Installation Regulation Review Meeting, Notes

### References Administrators and their Contact Details include:

Australian Energy Market Commission	<a href="http://www.aemc.gov.au">www.aemc.gov.au</a>
Australian Energy Regulator	<a href="http://www.aer.gov.au">www.aer.gov.au</a>
Electricity Retailers	<a href="http://www.esc.vic.gov.au">www.esc.vic.gov.au</a> – Licences Issued
Energy Safe Victoria	<a href="http://www.esv.vic.gov.au">www.esv.vic.gov.au</a>
Essential Services Commission	<a href="http://www.esc.vic.gov.au">www.esc.vic.gov.au</a>
Australian Energy Market Operator	<a href="http://www.aemo.com.au/">www.aemo.com.au/</a>
Standards Australia	<a href="http://www.standards.org.au">www.standards.org.au</a>
Victorian Electricity Distributors	– See Section 3 of these Rules.
Victorian WorkCover Authority	<a href="http://www.workcover.vic.gov.au">www.workcover.vic.gov.au</a>
Victorian Electricity Supply Industry	<a href="http://www.vesi.com.au/">www.vesi.com.au/</a>

## 1.3 Definitions

The definitions contained herein apply to these Service & Installation Rules and may vary from definitions contained in other documents.

**Accessible, readily** - has the same meaning as it has in the Australian/New Zealand Wiring Rules

**Advanced Metering Infrastructure (AMI)** – The infrastructure associated with the installation and operation of electricity metering and communications including interval meters designed to transmit data to and receive data from a remote locality.

**Allocated Maximum Demand** – the demand of the electrical installation as assessed by the Responsible Officer and specified in writing.

**Authorised Person** – the person in charge of the premises, or the registered electrical contractor or licensed electrical installation worker or other person appointed or selected by the person in charge of the premises, to perform certain duties associated with the electrical installation on the premises, as defined in the Wiring Rules

**Battery Energy Storage System (BESS)** - Consists of Power Conversion Equipment (PCE), battery system(s), protection devices and all the necessary additional equipment. (Examples include d.c./a.c., inverters, d.c./d.c. converters, charge controllers, etc)

**Carriageway** - that part of a road which carries vehicles.

**Certificate of Electrical Safety (CoES)** - a certificate of compliance as required by the Electricity Safety Act for electrical installation work carried out by a licensed electrical installation worker

**Child** – A child metering point is a metering point which has a relationship to a parent metering point such that the arithmetical difference between the energy measured at the parent metering point and the child metering point represents the energy consumption for one or more other connection points.

**Common Area** – an area within a multiple occupancy premises used by the occupiers of the premises and visitors. Note, Common Areas typically become Common Property in the event a property subdivision occurs.

**Common Property (CP)** – land shown as common property on a plan of subdivision or a plan of strata or cluster subdivision.

**Consumer’s Mains** – The conductors installed between the point of supply/consumer’s terminals and the main switchboard.

**Consumer’s Terminals** – the electrical junction at which the Distributor cable or supply conductors connect to the customer's installation or consumer's mains within the customer's property.

**Customer** – a person or organisation whose electrical installation is connected to the Distributor’s distribution system or who may want to have its electrical installation connected to the Distributor’s distribution system.

**Customer Agent/s** - Customer agents are parties representing the customers. Such parties may include registered electrical contractors, licensed electrical workers, licensed electrical inspectors, consulting engineers, architects, and equipment manufacturers.

**Deemed** - regarded, considered or judged.

**Deemed Distribution Contract** – as defined in the Electricity Distribution Code.

**Distributor** – a person who holds a Distribution Licence, or who is exempted from holding a licence of the Electricity Industry Act.

- “Distributor” is also known as the Local Network Service Provider (LNSP).
- “relevant Distributor” is the Distributor who operates the Network in the area associated with an electrical installation.

**Distribution Licence** – a licence to distribute and supply electricity granted under the Electricity Industry Act.

A2

**Electrical Work Request (EWR)** – A notification document as required by Section 4

**Electricity Distribution Code** – the Electricity Distribution Code administered by the Essential Services Commission.

**Electricity Safety Act 1998 (ESA)** - The Act is to make further provision relating to—

A2

- (a) the safety of electricity supply and use; and
- (b) the reliability and security of electricity supply; and
- (c) the efficiency of electrical equipment.

A3

**Electricity Safety (General) Regulations 2019 ES(G)R** – Regulations prescribed by the Electricity Safety Act

**Electrical Installation** – The consumer’s terminals, their enclosure, and all wiring and equipment downstream and supplied from those terminals, except for the Distributor’s network assets and where applicable, the metering assets.

An electrical installation does not include Distributors network assets including:

- The meter equipment located within an electrical installation including the service and distribution equipment upstream of the consumer’s terminals.
- The Network assets on land occupied by a Distributor that are not used for the consumption of electricity on that land or incidental to that consumption.
- Fuse cartridges for a Supply Protection Device and/or Occupancy Disconnection Device

**Embedded generator** - Any electrical energy source that can connect to the distribution network.

**Embedded Network (EN)** – An embedded network is a distribution network which has a connection point to another distribution network and does not have a connection point to a transmission network.

**Embedded Network Manager (ENM)** - is a service provider accredited by the Australian Energy Market Operator (AEMO). The purpose of the ENM is to facilitate the transfer of a customer from off-market to on-market (and back again if required).

A2

**Embedded Network Operator (ENO)** – Although not a registered participant in the National Electricity Market, a person or body that is responsible for and authorised by the relevant Regulators, to operate an electrical installation with multiple electricity customers, and to convey electricity through the electrical installation of the person or body after the electricity leaves a supply facility owned or operated by a distribution company and before being supplied to the customer.

**Embedded Network Operator Customer (ENOC)** – A customer within and connected to an ENO electrical installation that chooses to purchase electrical energy from the Embedded Network Operator rather than the National Electricity Market.

**Field Works Order (FWO)** - Where the Customer or Customers agent who requests Distributor work to take place and re-assigns Distributor charges to another party.

A2	<p><b>High Voltage (HV)</b> - has the same meaning as it has in the Australian/New Zealand Wiring Rules</p>
A3	<p><b>Informative</b> - has the same meaning as it has in the Australian/New Zealand Wiring Rules</p> <p><b>Inverter Energy System (IES)</b> – has the same meaning as it has in AS/NZS 4777 Series</p> <p><b>LEI</b> – Licensed Electrical Inspector</p> <p><b>LEIW</b> – Licensed Electrical Installation Worker</p> <p><b>Licensed electrician</b> – an Licensed Electrical Installation Worker (LEIW) holding an electrician’s licence under Part 3 of the Electricity Safety (Registration and Licensing) Regulations.</p>
A2	<p><b>Local Network Service Provider (LNSP)</b> is the distribution network provider that is normally adjacent to the embedded network.</p> <p><b>Low Voltage (LV)</b> - has the same meaning as it has in the Australian/New Zealand Wiring Rules</p>
A3	<p><b>Metal Clad Switchgear</b> - Switchgear and control gear assemblies with an external metal enclosure intended to be earthed and completely assembled, except of external connections</p> <p><b>Metering Code</b> – the laws, codes, or other regulatory instruments about metrology applicable to a particular customer which may include one or more of the:</p> <ul style="list-style-type: none"><li>(a) National Electricity Rules;</li><li>(b) Metrology Procedure; and</li><li>(c) Electricity Customer Metering Code.</li></ul> <p>These documents cover Embedded Network metering for the Parent and Child meter types, accuracy, maintenance, records and responsibilities and stipulates that the Parent Meter shall be an Interval meter. The LNSP will provide metering to NEMC child supply points less than 160MWh as required by the expiry of derogation from the NER in Victoria.</p> <p><b>Metering Coordinator (MC)</b> - is a registered participant role within the National Electricity Market (NEM), with the overall responsibility for metering services at a customer's connection point within a distribution or transmission system</p>
A2	<p><b>Metering Marshalling Point (MMP)</b> – the location where the wiring from the high voltage current and voltage transformers, terminate behind the meter panel.</p> <p><b>Metering Provider (MP)</b> – A person who meets the requirements listed in the National Electricity Rules and has been accredited by and registered by AEMO as a Metering Provider.</p> <p><b>Metering Terminal Point (MTP)</b> – the location where the wiring from the high voltage current and voltage transformers terminate in the LV area of the high voltage switchboard</p> <p><b>National Electricity Market Customer (NEMC)</b> is a customer who is allocated a National Metering Identifier (NMI) and purchases electrical energy through the National Electricity Market from a licensed electricity Retailer.</p> <p><b>Occupancy</b> – an electrical installation or part thereof, which is supplied with electricity through a specific meter or meters and for which an individual electricity consumption account is rendered.</p> <p><b>Occupancy Disconnection Device (ODD)</b> – A device provided for the purpose of disconnection and reconnection of individually metered occupancies within multiple occupancy premises.</p> <p><b>Occupancies Multiple or Multiple Occupancies</b> – more than one Occupancy connected to the same electrical installation.</p>

**Owners Corporation (OC)** – a body corporate which is incorporated by registration of a plan of subdivision or a plan of strata or cluster subdivision;

**Parent Metering Point** – A parent metering point is a metering point through which the energy measured is supplied to more than one connection point.

**Point of Attachment (POA)**– The point at which an overhead aerial service cable is attached.

**Point of Supply (POS)** – the point at which the electricity Distributors service cable or supply main connects to the consumer’s terminals. Refer to Section 6 (Point of Supply). (The Electricity Safety Act regulates Points of Supply locations)

**Private Electric Line (PEL)** – has the same meaning as the ES Act.

**Private Aerial Line (PAL)** – has the same meaning as the ES Act.

**Property** – “Property” is defined in clause 6.2 (Point of Supply).

**Public Land** – “Public Land” is defined in Section 5 (Private Electric Lines in Public Land)

**REC** – Registered Electrical Contractor.

**Readily Accessible** – See Accessible, Readily

**Responsible Officer (RO)** – the officer appointed by the relevant Distributor to be responsible for the administration of these Rules.

Dependent on a Distributor’s structure, there may be multiple Responsible Officers with specific responsibilities, eg, negotiation for supply, provision of substations, specification of points of supply, types of supply, servicing and metering etc.

**Retailer** – a holder of a Retail Licence, or a person who has been exempted from the requirement to obtain a Retail Licence under the Electricity Industry Act.

**Retail Licence** – a licence to sell electricity otherwise than through the Pool granted under the Electricity Industry Act.

**Service Cable / Line** – the final span or section of a Distributor’s low voltage aerial or underground network asset that is connected to the consumer’s terminals.

**Service Connection Facility (SCF)** – A facility containing consumer’s terminals provided for the connection of a Distributor’s service cable, eg, pillar, cubicle, switchboard or CT enclosure.

**Service Equipment** – equipment owned by the Distributor and used to connect supply to an Electrical Installation

**Shall** – is to be understood as mandatory.

**Should** – is to be understood as a recommendation

**Subdivision** – the division of land into two or more parts which can be disposed of separately.

**Suitable (or suitably)** – to the satisfaction of the Distributor’s Responsible Officer.

**Supply, Alternative** - A supply system intended to maintain the functioning of an electrical installation or a part or parts thereof, in case of interruption of the normal supply.

**Supply Capacity Control Device (SCCD)**– a device other than a fuse cartridge to limit the maximum demand of an Electrical Installation as per Section 6 of these rules

**Supply, Normal** - The source of supply that the electrical installation is supplied from under normal conditions of operation.

NOTE: The normal supply is usually from a distribution network, but may instead be from a generation system

A2

**Supply Protection Assembly (SPA)** - assembly for the purpose of accommodating the Supply Protection Device eg; Fused Overhead Line Connector Box, Panel Mounted Fuse or Fused Switch Disconnecter

**Supply Protection Device (SPD)** – a device required by the Electricity Safety (General) Regulations and Section 6 of these Rules.

**Supply, Supplementary** - A supply system intended to operate in conjunction with the normal supply.

**Uninterruptible Power Supply (UPS)** – A combination of convertors, switches and energy storage devices (for example batteries) constituting a power system for maintaining continuity of load power in case of input power failure.

**Wiring Rules** – the Wiring Rules published by Standards Australia as applied under the Electricity Safety Act and Regulations.

## 1.4

### Abbreviations

**ACB** – Air Circuit Breaker

**AEMO** – Australian Energy Market Operator

**AER** – Australian Energy Regulator

**AMI** – Advanced Metering Infrastructure

**BESS** – Battery Energy Storage System

**CB** – Circuit Breaker

**CFA** – Country Fire Authority

**CoES** - Certificate of Electrical Safety

**CP** – Common Property

**CT** – Current Transformer

**EN** – Embedded Network

**ENO** – Embedded Network Operator

**ENOC** – Embedded Network Operator Customer

**ENM** – Embedded Network Manager

**ESA** - Electricity Safety Act 1998

**ESC** – Essential Service Commission

**ES(G)R** - Electricity Safety (General) Regulations 2019

**ESV** – Energy Safe Victoria

**EWR** - Electrical Work Request

**FOLCB** – Fused Overhead Line Connector Box

**FSD** – Fused Switch Disconnecter

**FWO** - Field Works Order

**HV** - High Voltage

**ILAC** - International Laboratory Accreditation Cooperation

**IES** – Inverter Energy System

**LEI** – Licensed Electrical Inspector

**LEIW** – Licensed Electrical Installation Worker

**LNSP** – Local Network Service Provider

	<b>LPG</b> - Liquid Petroleum Gas
	<b>LV</b> - Low Voltage
	<b>MC</b> – Metering Coordinator
	<b>MCB</b> – Miniature Circuit Breaker
A2	<b>MCCB</b> – Moulded Case Circuit Breaker
	<b>MEN</b> – Multiple Earthed Neutral
	<b>MMP</b> - Metering Marshalling Point
	<b>MP</b> - Metering Provider
	<b>MSATS</b> – Metering Settlement and Transfer Solution
A3	<b>NATA</b> - National Association of Testing Authorities
	<b>MTP</b> - Metering Terminal Point
	<b>NEM</b> - National Electricity Market
	<b>NEMC</b> – National Electricity Market Customer
	<b>NER</b> – National Electricity Rules
	<b>NGZ</b> – No Go Zone
A2	<b>NMI</b> – National Metering Identifier
	<b>ODD</b> - Occupancy Disconnection Device
	<b>O/H</b> - Overhead
	<b>OC</b> - Owners Corporation
	<b>POA</b> - Point of Attachment
	<b>POS</b> - Point of Supply
	<b>PEL</b> - Private Electric Line
	<b>PAL</b> - Private Aerial Line
	<b>PVC</b> - Polyvinyl Chloride
	<b>U/G</b> - Underground
	<b>UPS</b> – Uninterruptible Power Supply
	<b>REC</b> – Registered Electrical Contractor
	<b>RO</b> - Responsible Officer
	<b>SFC</b> - Service Connection Facility
	<b>SCCD</b> - Supply Capacity Control Device
	<b>SPA</b> – Supply Protection Assembly
	<b>SPD</b> - Supply Protection Device
	<b>SWER</b> – Single Wire Earth Return
	<b>SWL</b> – Safe Working Load
	<b>UPS</b> - Uniteruptable Power Supply
	<b>VESI</b> – Victorian Electricity Supply Industry
	<b>VPI</b> – Victorian Power Industry
	<b>VSIR</b> – Victorian Service & Installation Rules
	<b>XLPE</b> - Cross-linked Polyethylene

## 1.5 SYMBOLS



SWITCH



TRANSFORMER



DISCONNECTOR



GENERATOR



SWITCH  
DISCONNECTOR



PV ARRAY



CIRCUIT BREAKER



INVERTER



FUSED SWITCH  
DISCONNECTOR

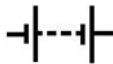

BATTERY

A2

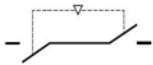

INTERLOCKED  
CHANGEOVER SWITCH

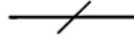

SINGLE PHASE



FUSE



TWO PHASE

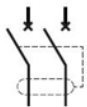

RCD



THREE PHASE



EARTH OR NEUTRAL  
BAR



EARTH



# Section 2

## Introduction

<b>Section 2 – Contents</b>		<b>Page</b>
<b>2.1</b>	<b>Disclaimer</b>	<b>2-3</b>
<b>2.2</b>	<b>Copyright</b>	<b>2-3</b>
<b>2.3</b>	<b>Innovation</b>	<b>2-3</b>
<b>2.4</b>	<b>Objective</b>	<b>2-3</b>
<b>2.5</b>	<b>Users</b>	<b>2-3</b>
<b>2.6</b>	<b>Publication and Revision</b>	<b>2-4</b>
2.6.1	Administration	2-4
2.6.2	Publication	2-4
2.6.3	Revision	2-4
Figure 2.6-A	Revision Process	2-4
<b>2.7</b>	<b>SIR Management Committee Contact</b>	<b>2-5</b>
<b>2.8</b>	<b>Dispute Resolution</b>	<b>2-5</b>
<b>2.9</b>	<b>Scope</b>	<b>2-5</b>
<b>2.10</b>	<b>Application &amp; Application Responsibilities</b>	<b>2-5</b>
<b>2.11</b>	<b>Failure to Comply with These Rules</b>	<b>2-5</b>
<b>2.12</b>	<b>Exceptional Circumstances</b>	<b>2-6</b>
<b>2.13</b>	<b>Offences</b>	<b>2-6</b>
<b>2.14</b>	<b>Necessity for Employing a Licensed Person</b>	<b>2-6</b>
<b>2.15</b>	<b>Basic Industry Relationship</b>	<b>2-7</b>
2.15.1	Scope	2-7
Figure 2.15-A	Stakeholders	2-7
2.15.2	Electricity Customer Metering Code Definitions	2-7
2.15.3	Responsibilities	2-8
2.15.3.1	Distributors	2-8
2.15.3.2	Retailers	2-8
2.15.3.3	Customer Agents	2-8

## 2.1 Disclaimer

A1 | These Rules have been published by CitiPower, Jemena Electricity Networks, Powercor Australia, AusNet Services and United Energy. The document has been compiled using drawings, guidelines and information that comply with the relevant Acts and Regulations of the State of Victoria at the date of publication. It is the responsibility of the end user to determine the suitability of material contained herein to the particular application or purpose of which it is used. Electricity supply publications are revised when necessary by the issue of either revised pages or complete new editions. It is important that users of such publications ascertain they are in possession of the latest issue.

A2 | **WARNING:** Printed copies of this document may not be the latest. The most up to date version is located on the VSIR website. [www.victoriansir.org.au](http://www.victoriansir.org.au)

CitiPower, Jemena Electricity Networks, Powercor Australia, AusNet Services and United Energy each expressly disclaim any liability, joint or several, to anyone including, without limitation, any end-user of this document, in respect of anything done by them in reliance in whole or in part upon the contents of this document.

## 2.2 Copyright

A1 | COPYRIGHT © 2013 CitiPower, Jemena Electricity Networks, Powercor Australia, AusNet Services and United Energy.

All rights are reserved, although the above Distributors will not object to the reproduction or copying of this document or sections of the document for the purpose of education or enhancing the Rules application.

A1 | However, no part of this document may be reproduced or copied for financial gain in any form without first obtaining the express written permission of the Service and Installation Rules Management Committee on behalf of CitiPower, Jemena Electricity Networks, Powercor Australia, AusNet Services and United Energy.

Inquiries concerning copyright should be directed to the Rules Management Committee.

## 2.3 Innovation

These Rules do not preclude other methods, innovation, or technology that achieves the same outcomes as the specifications detailed in this document. Any such proposal should be put to the relevant Distributor or the Rules Management Committee for acceptance prior to commencement of work.

## 2.4 Objective

The objective of these Rules is to provide Victorian electricity customers with industry agreed Distributor reasonable technical requirements (Rules) that meet all legislative and code requirements for the supply and metering related aspects of any connection to the Victorian electricity supply networks.

This is intended to result in significant economies of scale and industry efficiencies due to relatively consistent application of common electricity supply Rules across Victoria.

## 2.5 Users

The main users of this document are Distributors and Retailers, their customers, the customer's agents, and associated industry parties and personnel.

These include registered electrical contractors, licensed electrical workers, licensed electrical inspectors, consulting engineers, architects, electricity Distributor's personnel, electricity Retailer's personnel, Metering Providers, equipment manufacturers, representative organisations such as unions, associations, training providers and students,

the industry ombudsman, and other persons associated with the connection of customer electrical installations to electricity supply networks.

## 2.6 Publication and Revision

### 2.6.1 Administration

The revision, development and publication of these Rules is administered by the Victorian Service and Installation Rules Management Committee. The committee comprises of representatives from CitiPower, Jemena Electricity Networks, Powercor Australia, AusNet Services and United Energy.

Committee advisers at the time of publication include representatives from Energy Safe Victoria, Institute of Electrical Inspectors, the National Electrical and Communications Association and Master Electricians & the Clean Energy Council.

A2 |

### 2.6.2 Publication

The Victorian Service and Installation Rules were first published in 1987 by the SECV and Local Government Electricity Suppliers. Amended rules were published in 1988, 1991 and 1994 by those authorities. Additional amendments were made in 1996, 1999, 2001, 2003 and 2005 by electricity Distributors CitiPower, Jemena Electricity Networks, Powercor Australia, AusNet Services and United Energy and their predecessors. This edition is applicable from 1 January 2014 with subsequent amendments (A1) April 2017, (A2) July 2019 and (A3) October 2022.

A3 |

### 2.6.3 Revision

Although changes to regulations are usually the catalyst for revisions, users and interested parties are invited to provide comment and suggestions to assist further development of the Rules at any time. Correspondence for this purpose should be forwarded to the Service & Installation Rules Management Committee in accordance with clause 2.7 (SIR Management Committee Contact).

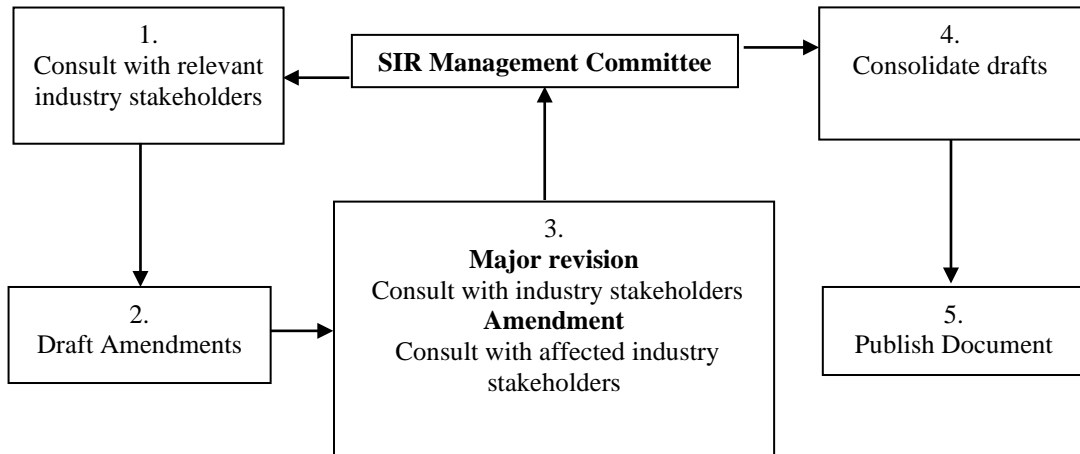

Figure 2.6-A Revision Process

## 2.7 SIR Management Committee Contact

Contact for any matter related to these Rules may be made through correspondence to the SIR Management Committee's web site [www.victoriansir.org.au](http://www.victoriansir.org.au)

Alternatively, contact may be made through the relevant Distributor.

## 2.8 Dispute Resolution

Where a customer has a complaint involving these Rules they should firstly contact the relevant Distributor's Responsible Officer and register their concern.

If not resolved, the complaint may be referred to a higher level person than the Responsible Officer within the Distributor's management structure. Where this does not result in a resolution, the complaint will be resolved in accordance with the Distributor's complaints and dispute resolution procedure as detailed within the individual company's charter.

## 2.9 Scope

A1 | These Service and Installation Rules form the major part of CitiPower, Jemena Electricity Networks, Powercor Australia, AusNet Services and United Energy "reasonable technical requirements" referred to in the Electricity Distribution Code.

A1 | The Rules apply in respect to all electrical installations that are connected or that are to be connected to CitiPower, Jemena Electricity Networks, Powercor Australia, AusNet Services and United Energy Victorian electricity supply networks.

However, there may be situations the Rules do not cover. These may include unusual connections, situations that have been inadvertently omitted, and alterations to legislation and codes. The relevant Distributor shall be consulted where these situations are encountered.

## 2.10 Application & Application Responsibilities

A2 | These Rules are applicable from 1 January 2014 and the publication date of subsequent amendments.

Transitional arrangements or exemptions may be able to be made with the relevant Distributor where it is deemed necessary to do so.

The relevant Distributor is responsible to administer all supply and metering related rules for connections to their electricity network.

A2 | Metering Coordinators are responsible for compliance with the metering requirements contained within these Rules.

Each Customer has an initial and ongoing responsibility to ensure their electrical installation complies with these Rules and any other conditions for supply. This is normally accomplished through their agents, eg, their Registered Electrical Contractor.

## 2.11 Failure to Comply with These Rules

Should the installation not satisfy these Rules, connection of electricity supply may be delayed, and installations on supply may be disconnected until such time as the non-compliance/s have been rectified

Re-inspection due to a failure to comply with these Rules may be undertaken by the Distributor and an Approved Charge for this service may apply.

Refer to the relevant Distributor for current fees.

## 2.12 Exceptional Circumstances

**FAQ 021**

In exceptional circumstances the stated requirements contained in these Rules may be waived or modified by submission of a written request.

The written request shall be accompanied by:

- i) a detailed statement of the reasons why non-compliance with these Rules is sought: and
- ii) a Statement of Consent from the owner or controlling body of the installation.

No action should be taken until a written reply to such a request has been received.

Any request in this regard shall be directed to the Nominated Officer of the relevant Distributor responsible for supply.

Contact information can be found at [www.victoriansir.org.au](http://www.victoriansir.org.au)

## 2.13 Offences

The Electricity Safety Act, the Electricity Industry Act and regulations, codes and guidelines enabled under those Acts include regulation for protection of Distributor assets and qualification of persons who may work on those assets. Offences under these regulations include:

- Any work on a Distributor's network assets unless authorised by the relevant Distributor
- Unauthorised interference with any Network Asset:
  - Fuse cartridge removal or insertion
  - Make or break of a connection, seal or lock
  - Dismantle or detach any Distributor's cables or equipment
  - Interference with electricity meters, time switches, equipment and/or service cables
  - Obtaining electricity by fraud
- Unauthorised access to a Distributor's sub-station or assets

If a person is found guilty of an offence, it could result in the imposition of substantial fines together with an order for damages to compensate the Distributor for any loss and court costs. It may also cause that person to have a criminal record.

## 2.14 Necessity for Employing a Licensed Person

Necessity for Employing a Licensed Person in Victoria, regulations only permit suitably licensed and/or qualified persons to work on electrical installations. In addition, registration requirements apply to the actual undertaking, or contracting to perform such work.

Enquiries regarding licensing, the qualifications to work, to undertake work, and/or to contract to perform electrical work on electrical installations should be referred to the Licensing Department, Energy Safe Victoria, Level 5, Building 2, 4 Riverside Quay, Southbank, 3006. Telephone (03) 9203 9700. or 1800 815 721 (free call). Licensing information is also available at [www.esv.vic.gov.au](http://www.esv.vic.gov.au)

## 2.15 Basic Industry Relationship

### 2.15.1 Scope

This section is intended to provide an understanding of the basic relationships of industry stakeholders, (regulators and Distributors, Retailers, Metering Providers, customers and their agents), in respect to connection of installations to Victorian electricity networks.

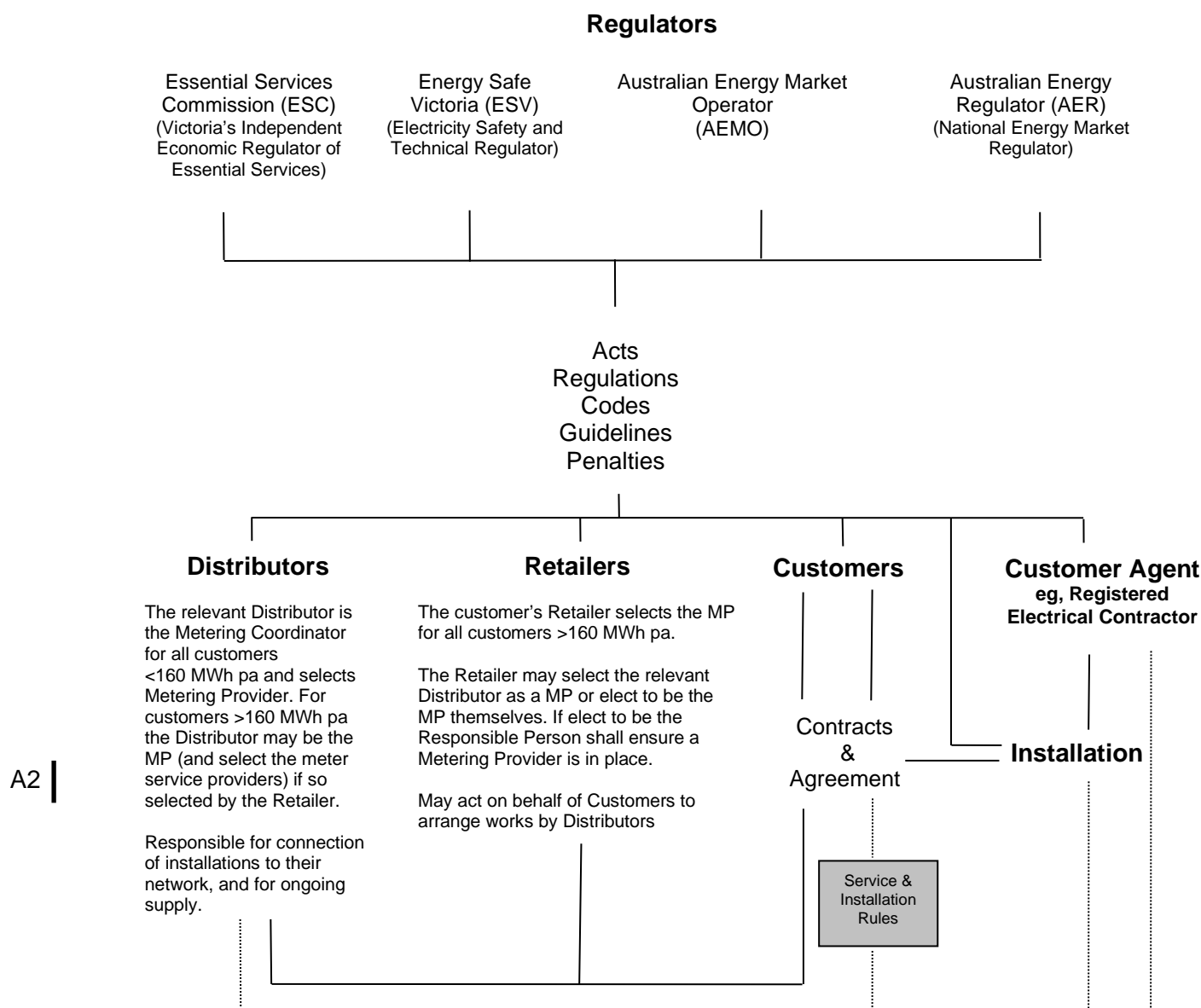

Figure 2.15-A Stakeholders

### 2.15.2 National Electricity Rules Definitions

Refer to the most recent versions of the National Electricity Rules and the Electricity Customer Metering Code for the relevant definitions.

## **2.15.3 Responsibilities**

### **2.15.3.1 Distributors**

- Negotiate provision of supply directly with customers
- Transport and deliver electricity purchased by Retailers and sold to customers.
- Connect customer installations to Distributor supply mains, administer technical supply aspects of the connection.
- Are the Metering Provider for first tier customers, and second tier customers where requested or agreed for second tier customers.
- A Distributor cannot energise a customer's installation unless the customer has selected a Retailer, and the Retailer has requested the Distributor to connect the customer.
- Are responsible for matters such as electricity supply quality and reliability.

### **2.15.3.2 Retailers**

- Purchase electricity and retail the electricity (transported by Distributors) to customers.
- Nominate tariffs and arrange customers contract for the purchase of electricity
- Provides the Distributor with details of the Metering Provider where the Distributor is not responsible for the metering.
- Request Distributors to connect or disconnect the customer installations to the Distributor's network in accordance with the customer's contract with the Retailer.

### **2.15.3.3 Customer Agents**

Customer agents are parties representing the customers. Such parties may include registered electrical contractors, licensed electrical workers, licenced electrical inspectors, consulting engineers, architects, and equipment manufacturers.



# Section 3

## Distributor Areas and Contact Details

A1 |

<b>Section 3 – Contents</b>	<b>Page</b>
<b>CitiPower</b>	<b>3-4</b>
<b>Jemena Electricity Network</b>	<b>3-5</b>
<b>Powercor Australia</b>	<b>3-6</b>
<b>AusNet Services</b>	<b>3-7</b>
<b>United Energy</b>	<b>3-8</b>

A2

# VICTORIAN DISTRIBUTION COMPANIES

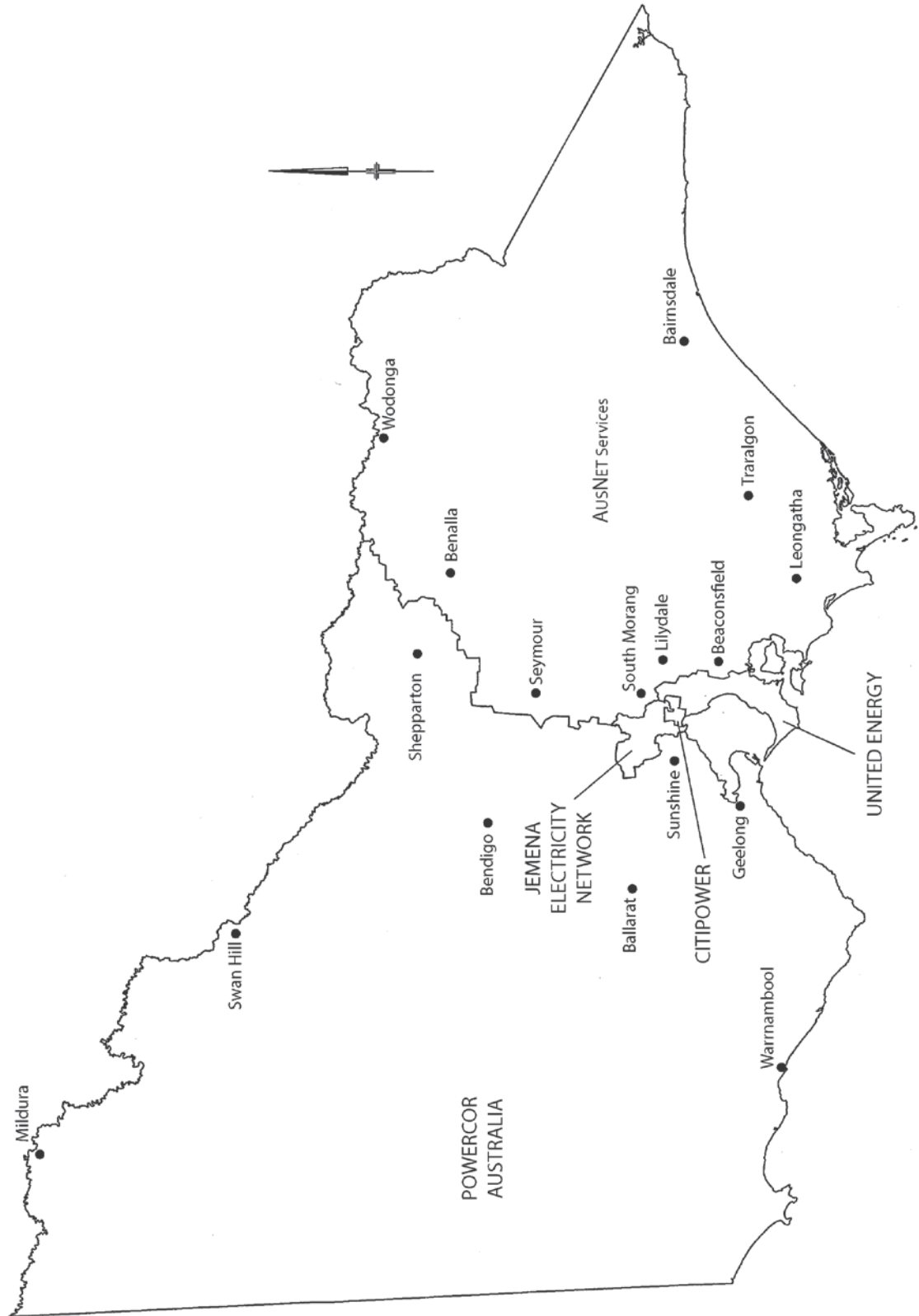

A3

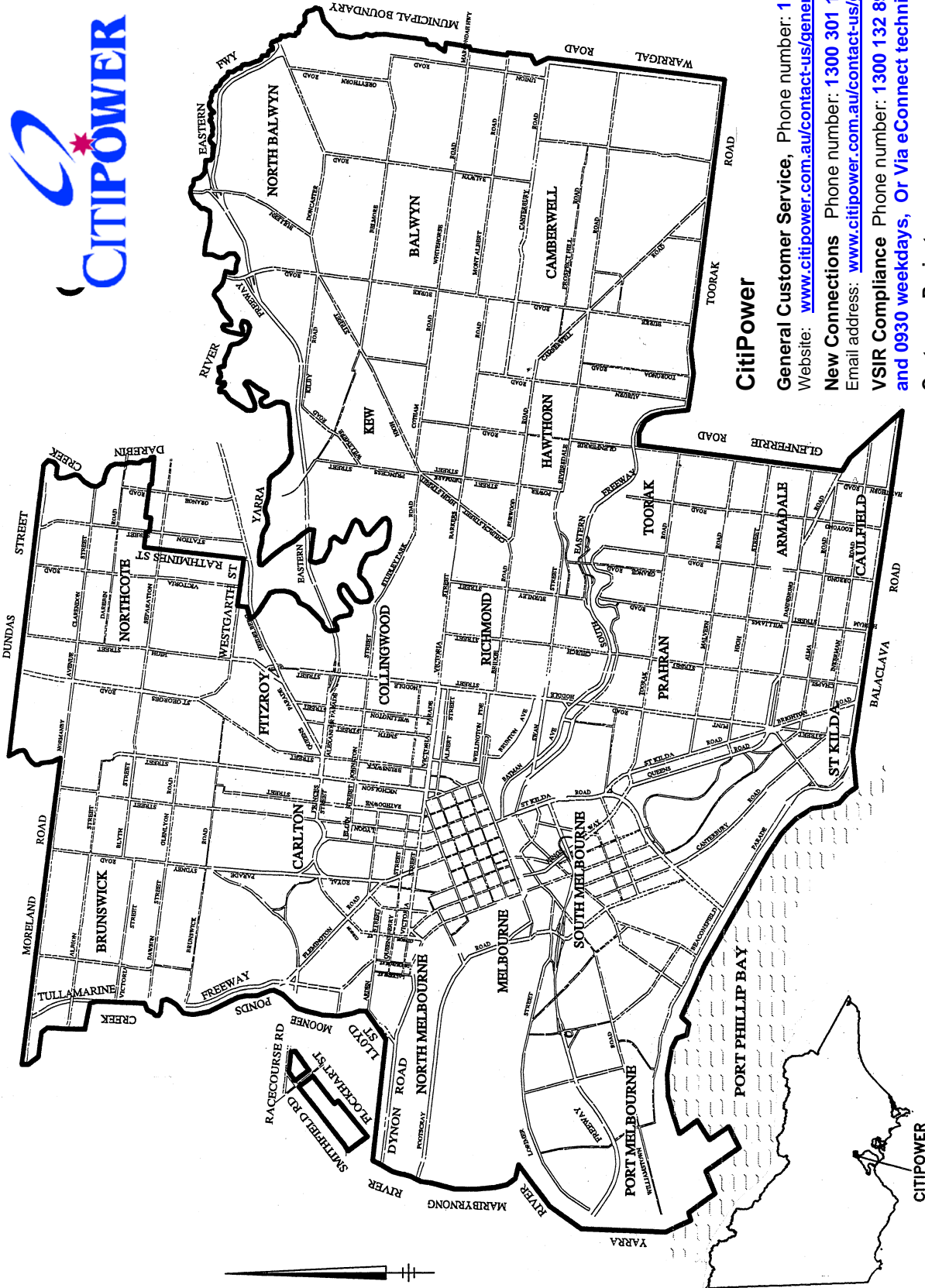

**CitiPower**

General Customer Service, Phone number: 1300 301 101

Website: [www.citipower.com.au/contact-us/general-enquiry/](http://www.citipower.com.au/contact-us/general-enquiry/)

New Connections Phone number: 1300 301 101

Email address: [www.citipower.com.au/contact-us/general-enquiry/](mailto:www.citipower.com.au/contact-us/general-enquiry/)

VSIR Compliance Phone number: 1300 132 894 between 0800 and 0930 weekdays, Or Via eConnect technical enquiries:

Customer Projects

Via: [customer.portal.powercor.com.au/mysupply/CIAWQuickCalculator](http://customer.portal.powercor.com.au/mysupply/CIAWQuickCalculator)

Faults & Emergencies Phone number 24hrs: 13 12 80



**Jemena**

**MELWAY REFERENCE**

361	362	363	364	365	366	367
361	362	363	364	365	366	367
333	331	352	176	177	178	179
328	323	324	3	4	6	7
335	355	13	14	15	16	17
28	29	27	28	29	30	31
36	40	41	42	43	44	45
82	54					

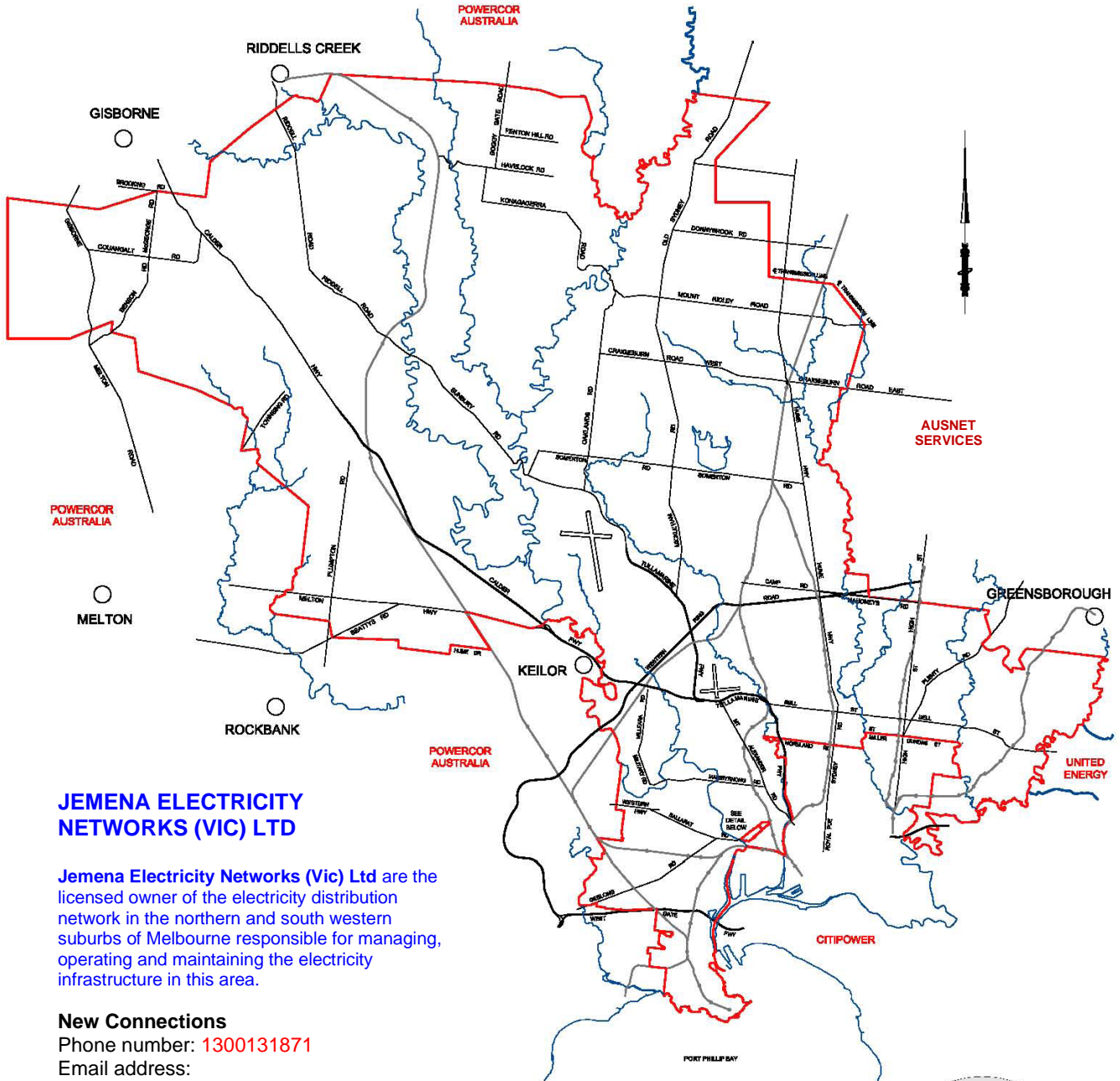
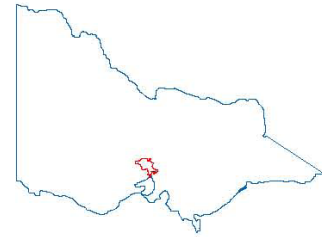

**JEMENA ELECTRICITY NETWORKS (VIC) LTD**

Jemena Electricity Networks (Vic) Ltd are the licensed owner of the electricity distribution network in the northern and south western suburbs of Melbourne responsible for managing, operating and maintaining the electricity infrastructure in this area.

**New Connections**

Phone number: **1300131871**  
 Email address: [networkconnections@jemena.com.au](mailto:networkconnections@jemena.com.au)

**VSIR Compliance (Electrical Professionals Only)**

Phone number: **1300855824**  
 Email: [zinfrajencpo@jemena.com.au](mailto:zinfrajencpo@jemena.com.au)

**Faults & Emergencies**

Phone number 24hrs: **131626**

**BOUNDARY MAP**

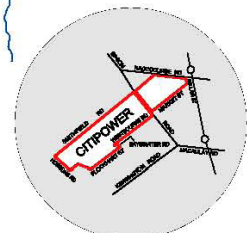



**Powercor**

**General Customer Service**

Phone number: **13 22 06**

Website:

[www.powercor.com.au/contact-us/general-enquiry/](http://www.powercor.com.au/contact-us/general-enquiry/)

**New Connections**

Phone number: **13 22 06**

Email address: [www.powercor.com.au/contact-us/general-enquiry/](mailto:www.powercor.com.au/contact-us/general-enquiry/)

**VSIR Compliance**

Phone number:

**1300 360 410 between 0800 and 0930 weekdays**

**Or Via eConnect technical enquiries:**

**[econnect.portal.powercor.com.au/customer/loginpage](http://econnect.portal.powercor.com.au/customer/loginpage)**

**Customer Projects**

Via:

**[customer.portal.powercor.com.au/mysupply/CIAWQuick Calculator](http://customer.portal.powercor.com.au/mysupply/CIAWQuickCalculator)**

**Faults & Emergencies**

Phone number 24hrs: **13 24 12**



POWERCOR

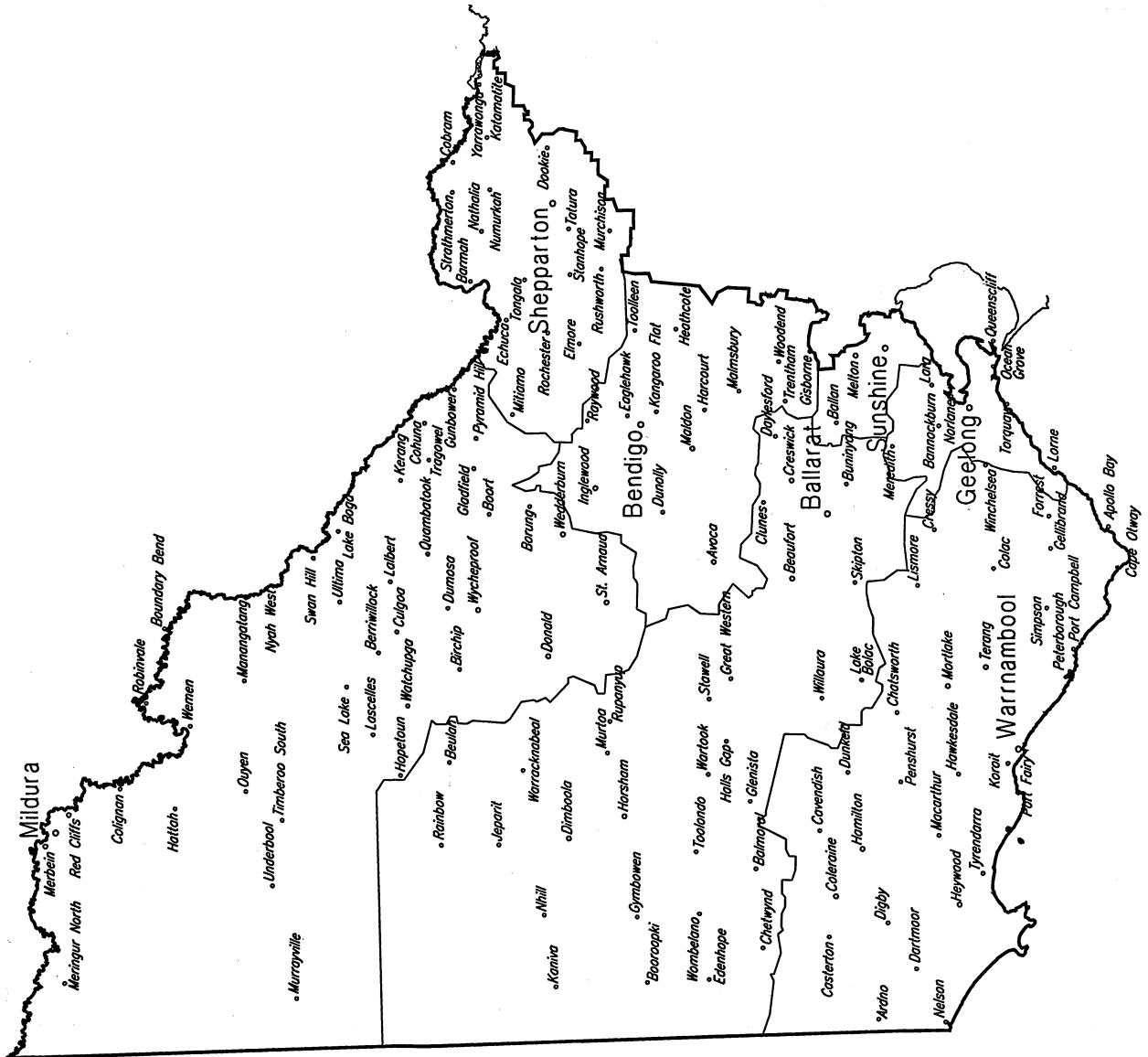

A3

A3

# AusNet

General Enquiries 1300 360 795  
 Faults & Emergencies 131 799  
 Area of Supply  
 Website [www.ausnetservices.com.au](http://www.ausnetservices.com.au)  
 Refer to road directories for  
 boundary details  
 VSIR Compliance  
 Email: [VSIRcompliance@ausnetservices.com.au](mailto:VSIRcompliance@ausnetservices.com.au)

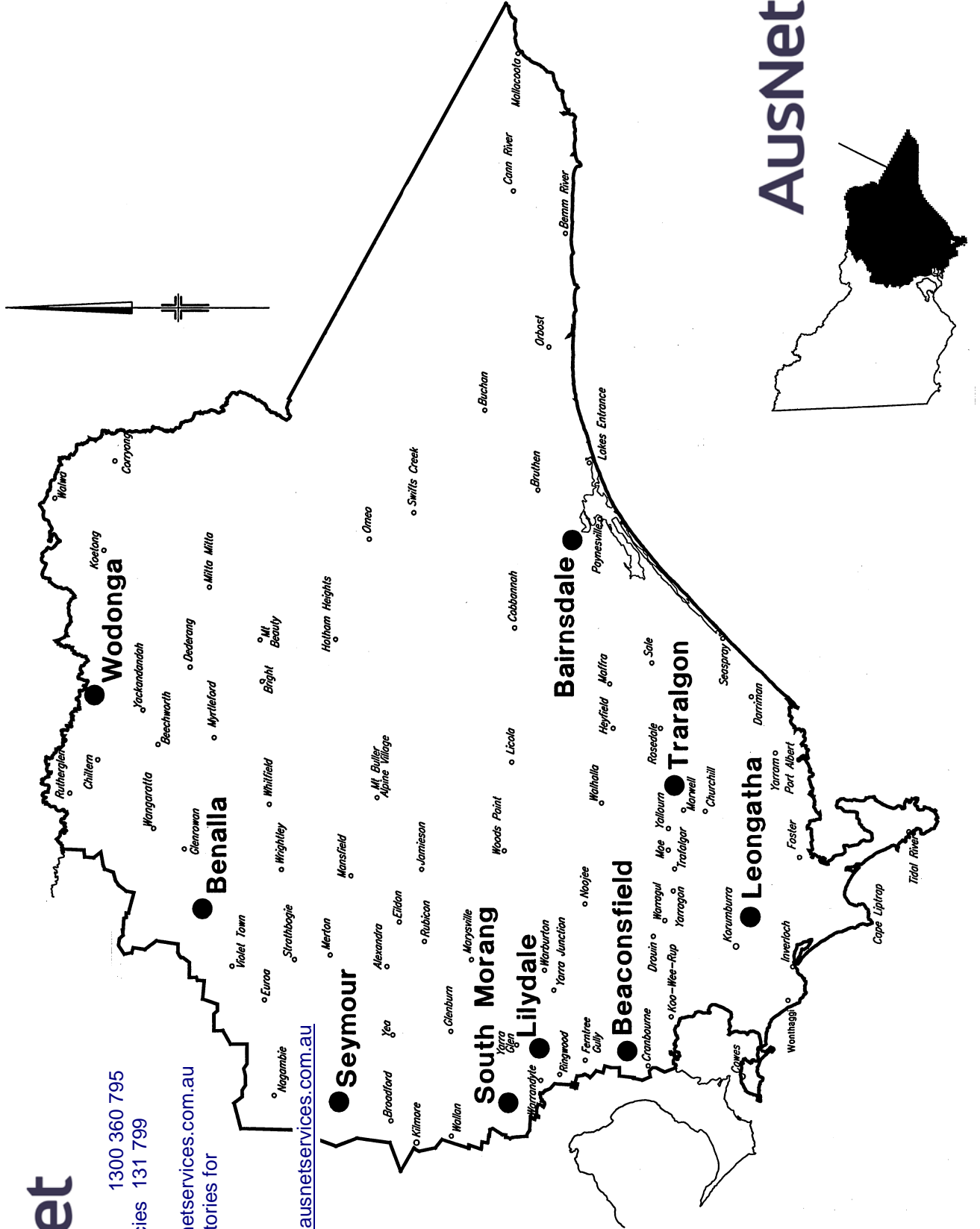

# AusNet

# United Energy Network Overview



A2

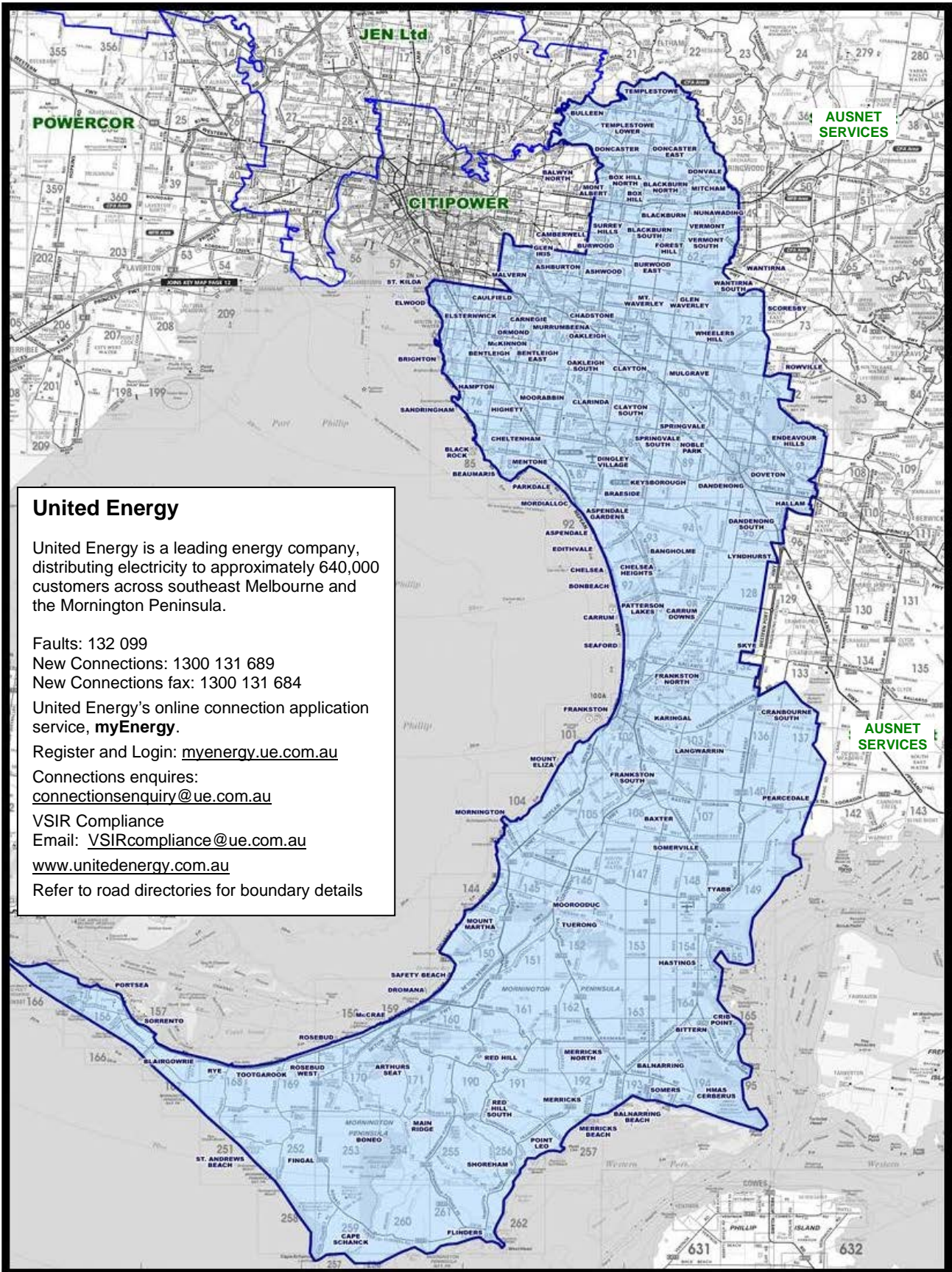

A3

Base Image Copyright Melways Publishing Pty Ltd



# Section 4

## Supply Application, Connection & Disconnection

<b>Section 4 - Contents</b>		<b>Page</b>
<b>4.1</b>	<b>Conditions of Supply</b>	<b>4-3</b>
<b>4.2</b>	<b>Negotiations for Obtaining / Altering an Electricity Supply and Warning Against Premature Expenditure</b>	<b>4-3</b>
<b>4.3</b>	<b>Typical Connection Process</b>	<b>4-4</b>
<b>4.4</b>	<b>Application for Supply Availability</b>	<b>4-4</b>
<b>4.4.1</b>	<b>Applications</b>	<b>4-4</b>
4.4.1.1	High Voltage Electrical Installations	4-4
4.4.1.2	Low Voltage Electrical Installations	4-4
(a)	New Electrical Installations	4-4
(b)	Existing Electrical Installations	4-5
<b>4.4.1.3</b>	<b>Electrical Installations on Public Land</b>	<b>4-5</b>
<b>4.4.2</b>	<b>Multiple Occupancy Buildings or Subdivisions (Application)</b>	<b>4-5</b>
<b>4.4.3</b>	<b>Distributor Substation on Customer's Premises</b>	<b>4-5</b>
<b>4.5</b>	<b>Notification of Electrical Work</b>	<b>4-5</b>
<b>4.5.1</b>	<b>New Connections &amp; Work Not Requiring an Appointment</b>	<b>4-5</b>
Table 4.5-1	Documents for Most Frequently Requested Work	4-6
<b>4.5.2</b>	<b>Work Requiring an Appointment</b>	<b>4-7</b>
<b>4.5.3</b>	<b>Other Documentation</b>	<b>4-7</b>
<b>4.6</b>	<b>Charges</b>	<b>4-7</b>
Form	Electrical Work Request (EWR)	4-9
Form	Field Works Order	4-10
Form	Application for Abolishment of Electrical Supply	4-11
Form	Deleted	4-12

## 4.1 Conditions of Supply

A Distributor's electricity contract or agreement applies to all electrical installations connected to a Distributor's electricity network. The contract or agreement specifies conditions for the supply of electricity from the network to the specific electrical installation.

The contract or agreement may be:

- an Electricity Supply Contract with a Retailer; and
- a specific electricity distribution connection agreement or contract; or
- a deemed electricity distribution contract. And where applicable:
- a Negotiated Connection Contract with the Distributor; and/or
- an electricity distribution demand tariff agreement or contract

A2

For example, a specific electricity distribution model standing offer or negotiated connection contract provides various agreed conditions for the connection of a particular electrical installation to the electricity network. These may include costs, responsibilities, type, capacity and point of supply, standards to be met, timeframe for provision of supply, etc.

Generic conditions of supply may or may not be included in the specific contract or agreement. These conditions are contained in legislation such as the Electricity Safety Act, the Electricity Industry Act and regulations, codes of practice and guidelines enabled by those Acts. For example, compliance with the Distributor's "reasonable technical requirements". ie, these Service and Installation Rules, is a condition of supply specified by the Electricity Distribution Code.

## 4.2 Negotiations for Obtaining / Altering an Electricity Supply and Warning against Premature Expenditure

Negotiations for the conditions for supply to a new electrical installation, or an addition or alteration to an existing electrical installation, or an additional load, including provision of a supply pit, should commence with the relevant Distributor as soon as the decision to proceed is made. Adequate written notice of the customer's proposed requirements should be submitted in accordance with clause 4.4 (Application for Supply Availability) and clause 4.5 (Notification of Electrical Work) at the earliest opportunity possible and the customer should be prepared to meet costs involved.

A2

Sufficient time shall be allowed for the Distributor to plan, determine and negotiate appropriate supply arrangements.

As the conditions for supply may have a significant effect on the installation design, the installations planning should not be completed, or construction commenced until supply negotiations have been completed with the Distributor. Conditions for supply may include but are not limited to:

- Location of the point of supply
- Type and capacity of supply
- Provision of the Distributor's equipment on the premises.
- Position of the metering and servicing equipment
- Point of attachment of an aerial service cable or installation of an underground service cable
- Position of any substation on the premises

## 4.3 Typical Connection Process

1. The Customer determines the supply requirement to suit their proposed electrical installation with their agent (eg, REC or electrical consultant).
2. Customer or Customer's Agent applies to Distributor for supply. Distributor requires advance notification of work required to be performed by the Distributor.
3. Distributor and Customer negotiate conditions for supply to the property.
4. Customer selects electricity Retailer and negotiates retail tariffs.
5. Customer Agent ascertains the electrical installations supply and metering requirements, completes electrical installation and provides Customer's Retailer with Electrical Work Request form, (available from Electricity Distributors), and the Certificate of Electrical Safety or CES procurement information.
6. Customer or Customers Agent applies to Retailer for connection.
7. Retailer's Metering Provider installs meters and requests Distributor to connect the electrical installation.
8. Distributor connects and energises electrical installation to supply on receipt of Certificate of Electrical Safety.

## 4.4 Application for Supply Availability

### 4.4.1 Applications

Customers with supply inquiries related to any electrical installation and customers requiring supply for the electrical installation types detailed in clauses 4.4.1.1 to 4.4.3 should contact the relevant Distributor detailed in Section 3 (Distributor Areas and Contact Details) as soon as a decision is made to proceed.

Applications for the proposed supply shall be in a form acceptable to the relevant Distributor.

Supply will be negotiated following receipt of the application for supply.

#### 4.4.1.1 High Voltage Electrical Installations

Applications are required for the following:

- Any new electrical installations including embedded generators and standby generators;
- Electrical installation alterations affecting supply protection arrangements; and
- Any changes effecting loading or contract conditions.

Refer to Section 9 High Voltage Electrical Installations for other requirements

#### 4.4.1.2 Low Voltage Electrical Installations

Applications are required for the following:

##### (a) New Electrical Installations

- Where supply is not available;
- Where supply has not been negotiated and allocated;
- Where supply negotiated and allocated to a developer is less than the proposed loading;
- Where proposed loadings exceed the existing contract or agreement;
- Where the electrical installation is proposed to incorporate an embedded generator, grid connected inverter, standby generator, or alternate source of supply; and

A2 |

- Any electrical installation proposed to be located or partially located in public land and/or on a Distributor's pole.

**(b) Existing Electrical Installations**

- Where a significant load increase is proposed;
- Where proposed loadings exceed the existing contract or agreement;
- Any proposed increased in load on a SWER distribution system;
- Where the electrical installation is proposed to incorporate an embedded generator, grid connected inverter, standby generator, or alternate source of supply;
- Where supply negotiated and allocated to a developer is less than the proposed loading; and
- Where extra phases or capacity to an electrical installation is required and/or proposed type of supply is not available.

**4.4.1.3 Electrical Installations on Public Land**

Applications are required for the following:

The relevant Distributor shall be contacted prior to finalising any proposal to install an electrical installation on public land or extending wiring and equipment from an electrical installation into or across public land.

Rules regarding acceptable arrangements may be referenced in Clause 5.7 (Private Electric Lines on Public Land).

**4.4.2 Multiple Occupancy Buildings or Subdivisions (Application)**

For the purpose of establishing an acceptable electricity supply arrangement associated with multiple occupancy buildings or subdivisions, it is essential certain information is submitted to the relevant Distributor in accordance with clause 5.8 Multiple Occupancy Buildings and Subdivisions (General).

**4.4.3 Distributor Substation on Customer's Premises**

If, in the opinion of the Responsible Officer, a substation on the premises is necessary to provide a new or increased supply, the requirements will be detailed with the offer of specific conditions of supply.

**4.5 Notification of Electrical Work**

**4.5.1 New Connections & Work Not Requiring an Appointment**

Upon or prior to the electrical installation's completion, connection and/or alterations of the connection to supply is required, the customer, customer agent and/or Retailer is responsible to provide required notification and details of the work to the relevant Distributor.

The documentation should be submitted at the earliest opportunity as a delay in receiving this information may result in a delay of the work taking place at the desired time.

This notification is required so the Distributor is aware of the work details and for the Distributor to arrange to connect the work or alter their assets to suit the work performed at the appropriate time.

Documentation shall be submitted to the relevant Distributor for these purposes and the most frequently requested work is included in Table 4.5-1.

**Table 4.5-1 Documents for Most Frequently Requested Work**

	<b>Type of Work</b>	<b>Document / Forms Required</b>	<b>Submission /How to apply</b>
	<b>New Electrical Installations</b> Connection request to new premises Where supply available with no Distributor work apart from the new connection	<ul style="list-style-type: none"> <li>Electrical Work Request* (EWR),</li> <li>Prescribed Certificate of Electrical Safety (CoES)</li> </ul>	Completed and submitted by the Customer Agent (e.g. REC) to the relevant Retailer or Distributor.  Note:***
A2	<b>Existing Electrical Installations</b> Alterations and additions to existing electrical installations or Isolation of supply request for maintenance work.	<ul style="list-style-type: none"> <li>Electrical Work Request* (EWR),</li> <li>Prescribed or Non-prescribed Certificate of Electrical Safety (CoES)</li> </ul>	Completed and submitted by the Customer Agent (e.g. REC) to the relevant Retailer or Distributor.  Note:***
	<b>Defective Electrical Installations</b> (e.g. defect issued by Distributor and off supply). <i>Re-Connection of the Electrical Installations with rectified Defects</i>	<ul style="list-style-type: none"> <li>Electrical Work Request* (EWR),</li> <li>Prescribed or Non-prescribed Certificate of Electrical Safety (CoES)</li> </ul>	Completed and submitted by the Customer Agent (e.g. REC) to the relevant Retailer or Distributor.
A3	<b>Re-Connection of existing Electrical Installation</b> For Installations that has been Off Supply Over 12 Months.	Evidence that an Installation is Safe to Reconnect, (e.g. EWR or letter from REC/ electrician)  (Note: a CoES** will be required for alterations, additions or repairs)	Submitted by the Customer Agent (e.g. REC/ electrician) to the relevant Retailer
	<b>Electricity Supply Abolishment</b> Permanent disconnection of the electricity supply and the removal of the Distributor's assets from customers premises. (e.g. Service Cable, Meters, Transformers, etc)	<ul style="list-style-type: none"> <li>Application for Abolishment of Electrical Supply*</li> </ul> Also available from Distributors Websites	<b>Supply Connected:</b> To be submitted by the customer to their Retailer to enable account to be closed and finalised <b>Supply Not Connected:</b> To be submitted by the customer or Customer's Agent to the relevant Distributor.
	<b>Installation of a new Distributors Service Pit</b> (Undergrounding service pit)	<ul style="list-style-type: none"> <li>Application for Installation of a Underground Service Pit</li> </ul> Available from Distributors Websites	Submitted by the Customer Agent (e.g. REC) to the relevant Distributor.
A2	<b>Embedded Generation Connection Request</b> (e.g. solar inverter connection including batteries )	<ul style="list-style-type: none"> <li>Electrical Work Request* (EWR),</li> <li>Prescribed Certificate of Electrical Safety (CoES)</li> </ul> Note: Application for connection of an embedded generation service available from Distributors Websites	Submitted by the Customer Agent to the Customer's Retailer.  Note: <i>Some Distributor have introduced connection portals where the PV application form is submitted</i>
<p>* Blank copies of these documents are placed at the end of section 4 for your convenience. These documents may be copied, completed and submitted in accordance with this table. Editable versions are also available from the Service and Installation Rules website</p> <p>** Where Prescribed Electrical Installation Work has been undertaken, a Prescribed CoES is required, and a copy shall be provided to the Distributor. Where the Electrical Installation Work is Non Prescribed, the sighting of the CoES and recording of the CoES Number by the relevant Distributor would suffice.</p> <p>*** Some Distributors have introduced connection portals that have replaced the paper based EWR's for submitting new connection requests.</p>			

## 4.5.2 Work Requiring an Appointment

In addition to submission of documentation specified in Clause 4.5.1 (New Connections & Work not requiring an appointment), to avoid delays, the customer's agent should contact the relevant Retailer or Distributor at the earliest opportunity for an appointment where the installation work needs to be co-ordinated with the Distributor, eg, "truck appointments". Delays in receiving this information may result in impeding the work taking place at the desired time.

## 4.5.3 Other Documentation

Other documentation is required for work associated with less common connection work. Examples of such work include multiple occupancies, working near network assets, HV electrical installations (refer to Section 9 High Voltage Electrical Installations), relocation of network assets, etc.

Details of documents required to be provided for these categories of work may be obtained from the relevant Distributor.

## 4.6 Charges

In addition to charges made by the Distributor for supply negotiated under Clause 4.4 (Application for Supply), a customer or customer agent will usually be required to pay a charge for customer initiated work carried out by a Distributor for the connection or alteration or additions involving Distributor assets and their installation.

Some examples of these charges include where:

- connection of supply is provided;
- alterations involving the existing service or metering equipment are requested;
- the service or metering equipment is considered by the Distributor to be special or additional;
- work is requested to be performed outside normal business hours; the customer or their agent fails to complete essential preparations or causes excessive delay after arrival of a service truck; and
- in the opinion of the Distributor, any alteration to the supply arrangements is required as a result of failure of the customer to comply with these Rules and the conditions under which the supply is made available.

Copies of many such charges can be referenced on Distributors and Australian Energy Regulator websites – see "references section" of this document. Details of charges should be determined and/or confirmed with the relevant Distributor prior to the work taking place.

The customer or customer's agent shall, if requested, sign an agreement in a form acceptable to the Distributor, before the Distributor's work is commenced, and may be required to pay prior to commencement of the work.

A2

**This page intentionally blank**





A3

Retailer:
Service Order:#
NMI:



### Field Works Order / Payment Form

Location of works

Customer / Occupier Name

Meter Number

Time Works Required: Day  Date

**Note: Appointments must be confirmed with the Distribution Company**

#### Description of Works

Item No	Work Required	Fee (\$) (office use only)
<input type="text"/>	<input type="text"/>	<input type="text"/>
<input type="text"/>	<input type="text"/>	<input type="text"/>
<input type="text"/>	<input type="text"/>	<input type="text"/>
<input type="text"/>	<input type="text"/>	<input type="text"/>
<b>TOTAL FEE PAYABLE</b>		<input type="text"/>

#### Applicant (BLOCK LETTERS PLEASE)

Name of person requesting works  Phone No

Address

Name of Organisation  Position

I hereby request \_\_\_\_\_ (the Distribution Company supplying the above premises) to undertake the works described above and agree to pay the account within 30 days.

I also understand and acknowledge that in the event of non payment of this account, the distribution company may refuse to perform further works I may request unless and until such account is settled.

Signature of Applicant \_\_\_\_\_ Print Name \_\_\_\_\_

Postal Address

Contractor involved  Phone No

Remarks

#### Payment Options

Please invoice me directly (CitiPower and Powercor only)

Please charge the following:  Visa  Mastercard Please call your distributor to arrange payment

Card Holder's Name

Contact Number for Payment

Signature

The Distribution Companies listed below comply with the Australian Privacy Principles applied under the Privacy Act 1988 and any other applicable laws that protect your privacy. Please refer to the relevant Distribution Companies website for more information on their Privacy Policies.

AusNet Services – 1300 360 795 CitiPower Pty – 1300 132 894 Jemena – 1300 131 871 Powercor Australia Ltd – 1300 360 410 United Energy – 1300 131 689

A3

Retailer:
Service Order:#
NMI:

AusNet



## Abolishment (Permanent Removal) of the Electricity Supply

**Note:** The applicant requests the permanent removal of the Electricity Distribution Companies metering and servicing assets associated with the property detailed below.

To ensure the prompt processing of your application, please ensure all details are accurately completed as incomplete or illegible applications will be returned to the applicant.

### Site Details

Address of Electricity Supply to be abolished	<input type="text"/>
NMI (if known)	<input type="text"/>
Site Access Details	<input type="text"/>
Abolishment in conjunction with other works	<input type="text"/>

The customer must provide unhindered and safe access to ensure the work can be carried out. In the event that access arrangements are insufficient for the work to be completed, a standard wasted service truck visit fee may be charged to you.

### Type of Electricity Supply to be Abolished

<input type="checkbox"/> Overhead	<input type="checkbox"/> Underground cable supplies	<input type="checkbox"/> Unmetered supply
<input type="checkbox"/> Multiple Services to the Site	<input type="checkbox"/> Substation direct supplies	

If more than one service to the site exists please indicate which supply is to be removed

### Electricity Meter to be Abolished

Accurate meter numbers assists us to identify the correct services to be abolished.

<input type="text"/>	<input type="text"/>	<input type="text"/>	<input type="text"/>
----------------------	----------------------	----------------------	----------------------

### Property Available for Abolishment

IS THE PROPERTY VACANT?  Yes  No      Actual Date Vacant

If not, please provide the date the property will be vacant – Please note the regulatory completion timeframe will not commence until the property is vacant as the Distribution Company is unable to attend prior to this time.

Preferred Date for Abolishment

### Applicant Details

**By completing this document, I acknowledge that I'm responsible for any Distribution Company charges unless a completed Field Works Order/Payment Form is submitted along with this form to defer the responsibility to another person. Please note that some Distribution Companies require pre-payment before the commencement of any work.**

Payment Details Submitted?  Yes  No

Name / Company responsible for the charges (unless completed field works order is submitted)		REC Details
<input type="text"/>		<input type="text"/>
Address for Invoice (unless completed field works order is submitted)		
<input type="text"/>		
Telephone Number	Email Address / Fax Number	Mobile Number
<input type="text"/>	<input type="text"/>	<input type="text"/>
<input type="text"/>		<input type="text"/>
Applicant's Authorised Signatory	Name (please print)	

**NOTE:** If the premise is occupied or the electricity supply is connected, this form must be submitted to the customer's Retailer. If the electricity supply is not connected, this form can be submitted to the relevant Distribution Company.

The Distribution Companies listed below comply with the Australian Privacy Principles applied under the Privacy Act 1988 and any other applicable laws that protect your privacy. Please refer to the relevant Distribution Companies website for more information on their Privacy Policies.

AusNet Services- 1300 360 795 Citipower Pty – 1300 132 894 Jemena – 1300 131 871 Powercor Australia Ltd – 1300 360 410 United Energy – 1300 131 689

Version 7 October 2014

**This page intentionally blank**

# Section 5

## General Rules

<b>Section 5 – Contents</b>		<b>Page</b>
<b>5.1</b>	<b>Safety</b>	<b>5-3</b>
5.1.1	No Go Zone	5-3
5.1.2	Underground Cables	5-3
5.1.3	Substations	5-3
5.1.4	Poles and Overhead Lines	5-4
5.1.5	Service Pits	5-4
5.1.6	Proximity of Electrical Installation and Distributor Assets	5-4
5.1.7	Supply Isolation	5-4
5.1.8	Remote De-energisation, Re-energisation	5-5
<b>5.2</b>	<b>Compliance with Regulations, Codes of Practices and these Rules</b>	<b>5-5</b>
5.2.1	General	5-5
5.2.2	Testing	5-5
5.2.3	Private Aerial Lines (PAL)	5-5
<b>5.3</b>	<b>Equipment Acceptance</b>	<b>5-6</b>
5.3.1	Equipment Required to be Accepted	5-6
5.3.2	Equipment Not Required to be Accepted	5-6
<b>5.4</b>	<b>Labelling</b>	<b>5-6</b>
<b>5.5</b>	<b>Access to Distributors' Equipment</b>	<b>5-7</b>
<b>5.6</b>	<b>Sealing and Locking</b>	<b>5-7</b>
5.6.1	General	5-7
5.6.1.1	Segregation	5-7
5.6.1.2	Provision for Sealing	5-7
5.6.1.3	Provision for a Padlock	5-7
<b>5.6.2</b>	<b>Victorian Power Industry Lock</b>	<b>5-7</b>
<b>Figure 5.6-A</b>	<b>Victorian Power Industry Locks</b>	<b>5-8</b>
<b>Figure 5.6-B</b>	<b>Electrical Metering Enclosure/Cabinet Lock (key code CL001)</b>	<b>5-8A</b>
<b>5.7</b>	<b>Private Electric Lines on Public Land</b>	<b>5-9</b>
5.7.1	General	5-9
5.7.2	Definitions	5-9
5.7.3	Legislation Summary	5-9
5.7.4	Responsibilities	5-9
5.7.5	Current Practices	5-10
5.7.6	Recording of Private Electric Lines on Public Land	5-11
<b>5.8</b>	<b>Multiple Occupancy Buildings and Subdivisions (General)</b>	<b>5-12</b>
5.8.1	General	5-12

A1

## 5.1 Safety

All persons and contractors are responsible for all aspects of safety related to work performed by these persons or contractors, their employees and agents.

The work should be performed in accordance with all relevant regulations, codes of practice, standards and the Rules within this document that are related to the safety of the work being performed. For further information contact the following websites <http://www.esv.vic.gov.au>

<http://www.worksafe.vic.gov.au>

### 5.1.1 No Go Zone

ESV and the Victorian WorkCover Authority (WorkSafe) requires all workers to comply with the “No Go Zone” Guidelines and Framework administered by those authorities. Additional information to that provided below may be referenced from ESV and VWA websites detailed in the “references” section of these Rules.

The framework sets out the requirements for the safe conduct of work near overhead and underground utility assets, including electricity network assets. In particular, it sets out the framework for the safe conduct of work near overhead lines, including the use of mobile plant, and the conduct of works involving excavations near underground cables and earthing systems.

It also specifies the safe limits of approach for workers engaged in these works and the need for obtaining the permission of the relevant Distributor when working near overhead and underground electricity network assets.

Customers and their agents shall consider these requirements when planning any works near Distributor’s assets and employ a safe system of work.

Where the No Go Zone rules stipulate, the relevant Distributor shall be contacted for permission and conditions to perform the work.

### 5.1.2 Underground Cables

Any works carried out by a customer or a customer’s agent in the vicinity of underground cables shall be carried out in accordance with Clause 5.1.1 (No Go Zone)

Customers and their agents shall contact “Dial Before You Dig” <http://1100.com.au/#> (Telephone 1100) to obtain information on the location of any existing underground assets before any works involving excavations are commenced.

### 5.1.3 Substations

Under no circumstances shall a customer or a customer’s agent enter a substation enclosure or climb a pole without first contacting the relevant Distributor and obtaining approval and permission to enter the substation and/or carry out the proposed works. This shall be done in accordance with Clause 5.1.1 (No Go Zone) and the conditions prescribed by the relevant Distributor.

Where cables are to be installed on or in a Distributor’s substation, no excavation work within 10m of the substation shall commence before the route of the cable has been approved by, and advice regarding the substation earthing system obtained from, the Responsible Officer.

In the case of a “Single Wire Earth Return” (SWER) substation, arrangements SHALL be made with the relevant Distributor to de-energise the substation prior to, and during trenching operations.

Where free standing switchboards and support structures are proposed to be installed within the vicinity of a high voltage earthing system associated with a substation the relevant Distributor shall be contacted to determine conditions related to its installation.

Note that damage to a high voltage-earthing conductor can cause an extremely hazardous situation.

#### **5.1.4 Poles and Overhead Lines**

Any works carried out by a customer or a customer's agent in the vicinity of overhead lines or poles shall be carried out in accordance clause 5.1.1 (No Go Zone).

Where free standing switchboards and support structures are proposed to be installed within the vicinity of a high voltage earthing system associated with a pole the relevant Distributor shall be contacted to determine conditions related to its installation.

All persons and apparatus shall maintain safe working clearances in accordance with the "No Go Zone" requirements. If this clearance cannot be maintained, the relevant Distributor shall be consulted before proceeding so that alternate arrangements can be made.

Except for reinstated poles, eg, staked, any pole marked with a large 'X' cut into or marked on the surface has a limited life and shall therefore be considered unsafe to climb or support a ladder.

#### **5.1.5 Service Pits**

Any cables within a service pit shall be treated as ALIVE and shall not be handled without taking appropriate safety precautions.

#### **5.1.6 Proximity of Electrical Installation and Distributor Assets**

The Electricity Safety Act and Regulations should be referenced for regulations pertaining to work in the vicinity of Distributors assets.

To ensure safety is maintained, clauses 5.1.3 (Substations) and 5.1.4 (Poles and Overhead Lines) place restrictions on the location of free-standing switchboards and support structures in the vicinity of substation high voltage systems.

The relevant Distributor should be contacted in all other circumstances where it is proposed to work, place structures or install sections of an electrical installation's wiring or equipment in the vicinity of network assets where not detailed in these Rules.

#### **5.1.7 Supply Isolation**

The relevant Distributor shall be contacted at the earliest opportunity to isolate supply where required to enable work to be performed safely.

Circumstances where the Distributor shall isolate supply is where the customer's agent cannot isolate supply by operation of the electrical installation's facilities such as main or isolation switches or operate the supply protection device/s in accordance with clause 6.8.4 (Operation). Refer to Code of Practice Low Voltage Service Fuse Removal and Reinsertion by Licensed Electricians and L & G Class Inspectors.

Supply isolation procedures, systems and costs will vary between Distributors, and contact with the relevant Distributor listed in Section 3 should be made to determine these conditions.



### 5.1.8 Remote De-energisation, Re-energisation

Remote De-energisation and Re-energisation is accomplished by opening or closing a contactor incorporated within the meter from a remote location

**WARNING:** Electrical workers undertaking electrical wiring work within electrical installations, which have been de-energised remotely, shall implement safety measures that will eliminate the dangers of contact with live parts, should remote re-energisation occur.

## 5.2 Compliance with Regulations, Codes of Practices and these Rules

### 5.2.1 General

Every new electrical installation, alteration, addition, maintenance or repair to an electrical installation to be connected or reconnected to the Distributor's mains is required to comply with the current edition of the Electricity Industry Act, Electricity Safety Act and the Regulations and Codes of Practices under jurisdiction of those Acts, including compliance with these Rules, and other relevant Acts, Regulations, Codes of Practice and Guidelines.

The Distributor may inspect the electrical installation or occupancy to determine compliance with these Service & Installation Rules.

### 5.2.2 Testing

The Electricity Safety Act and Regulations require all electrical installation work to be tested in accordance with that Act and Regulations. Underground consumer's mains shall also be tested to ensure compliance with SIR Clause 7.5.2.1 (Minimum Insulation Resistance).

### 5.2.3 Private Aerial Lines (PAL)

The Electricity Safety Act and Regulations regulate the construction, protection and inspection for PAL. These effectively require in part:

- The construction of a new PAL to be limited to low bushfire risk areas;
- The construction of a PAL to be in accordance with the Act, Regulations and the Wiring Rules;
- A PAL to be substantially re-constructed in a hazardous bushfire risk area to be placed underground;
- A circuit breaker to be fitted at the origin of any new PAL and when repairs are made to an existing PAL; and
- Distributors to inspect PALs within their network areas. These include the inspection scope, times and standards, and the form and time the notice of inspection is provided to the customer.

A private aerial line in a hazardous bushfire risk area that has been rendered inoperative by a fault and requires substantial reconstruction (as defined in the Regulations) shall be placed underground or be disconnected from electricity supply. An owner of such a line can provide a written undertaking (an undertaking form is available on the ESV website) to an REC to enable immediate repairs to be carried out by an REC. This legally binds the owner to have the line placed underground within 60 days after the date of the undertaking or have the line disconnected from electricity supply. An REC who receives an undertaking shall provide a copy of the undertaking and the COES for the repair work to ESV within 5 days of the completion of the work.

PAL that have serious non-compliances will be disconnected on declared total fire ban days.

## 5.3 Equipment Acceptance

Equipment used to interface with Distributor assets in accordance with these Rules shall comply with the Electricity Safety Act and Regulations and be of a standard acceptable to the relevant Distributor.

### 5.3.1 Equipment Required to be Accepted

The relevant Distributor may refuse to connect equipment required to be accepted that has not been accepted, and/or is not suitably identified in accordance with these Rules.

Service raiser brackets, and direct metering enclosures and surrounds that are intended to be stocked and marketed by Electrical Wholesalers and similar Distributors are required to be accepted for use by the SIR Management Committee prior to being connected to supply.

Service raiser brackets specifications may be referenced in Clause 7.4.4.5.3 (Specification, Acceptance and Installation) and all meter enclosures and surrounds in Clause 8.4 (Metering Facilities) and 8.8.2 (Meters - Temperature Limits of Specified Operating Range).

All inquiries and submissions relating to acceptance of equipment should be forwarded to the SIR Management Committee in accordance with Clause 2.7 (SIR Management Committee Contact) at the earliest opportunity.

### 5.3.2 Equipment Not Required to be Accepted

It is recommended manufactures and/or suppliers of equipment used to interface with Distributor assets and not required to be submitted for acceptance, submit their proposed equipment and installation arrangement to the Management Committee for comment prior to use where there is no clear evidence of compatibility or compliance with the Distributors assets and these Rules.

Examples of such equipment include supply protection devices, supply connection facilities, Current Transformer facilities, service brackets and meter enclosures not required to be accepted.

The relevant Distributor may require certified evidence of such equipment's compliance to the Rules specification and its suitability for its intended purpose. The relevant Distributor may accept such equipment, provided they are satisfied with the evidence provided.

Certified evidence may include provision of documents to certify compliance with the specification contained in these Rules and its intended purpose by a suitably qualified person, eg, an engineer, inspector or practitioner.

A Distributor may refuse to connect equipment where they are not satisfied that the relevant specifications have been met, and/or where suitable certified evidence is not provided.

## 5.4 Labelling

Every label required by these Rules shall be in English, permanent, indelible, legible and suitable for the purpose for which it is intended. For guidance, labels should be of laminate and manufactured with letters and numbers of not less than 6mm in height.

## 5.5 Access to Distributors' Equipment

A customer shall provide the Distributor's representatives at all times a safe, convenient and unhindered access to their equipment in accordance with these Rules and the Electricity Distribution Code for any purposes associated with the supply, metering or billing of electricity, inspection and/or testing of the customer's electrical installation including connection, disconnection or reconnection of supply.

## 5.6 Sealing and Locking

### 5.6.1 General

The customer shall make provision to limit unauthorised access to un-metered terminals and other equipment where required by these Rules. Acceptable methods to limit unauthorised access include the following:

#### 5.6.1.1 Segregation

Un-metered terminals segregated from other terminals and equipment by permanently fixed barriers, or barriers able to be fitted with a Distributor seal or lock;

#### 5.6.1.2 Provision for Sealing

A 1.6mm – 2mm diameter hole shall be provided where a Distributor's seal is to be fitted. The passage for the seal shall be double insulated or segregated from live equipment in such a manner that a metallic sealing wire could not be deemed to be exposed metal and require earthing under the Wiring Rules; and

#### 5.6.1.3 Provision for a Padlock

**FAQ 010**

A 6mm diameter hole shall be provided where a Distributor's padlock is to be fitted. Eg. un-metered sections switchboards, locking facilities for switches or circuit breakers controlling un-metered wiring, etc.

A3 |

All locking facilities shall be permanent and fit for purpose.

Clauses containing requirements for specific equipment and situations are detailed throughout these Rules.

### 5.6.2 Victorian Power Industry Lock

A Victorian Power Industry Lock is required where a Customer is obliged to or wishes to install a locking system to doors and enclosures which require dual access by both the Customer and Distributor representatives.

Locations for the use of the locks may be for perimeter gates, meter enclosures and supply connection facilities requiring convenient and unhindered access by both the Distributor and customer.

The system uses a Victorian Power Industry (VPI-2) Lock that is available in many lock styles, and which is available from many hardware outlets, electrical wholesalers and master locksmiths throughout Victoria, refer Figure 5.6.

The locks may only be operated by the customer's key and authorised Distributor representatives using a Master Key.

Unique customer keys are supplied with individual locks. However, a "key alike" system is available for the customer's key which enables the customer to use their key on as many of their VPI-2 locks as they choose. This enables customers to customise their locks to other locks compatible with the system.

The locks shall be subject to the following conditions:

- The locking system is only used where specifically referred to and permitted by these Rules
- Other locks may be customer keyed to this system but the Master Key will only operate the Power Industry Lock.

 <p>VPI-2 334B45 MT5+ 45mm Brass body, 19mm opening, 8.7mm thick shackle Padlock</p>	 <p>VPI-2 214A MT5+ 40mm Aluminium body, 19 mm opening, 5mm thick shackle for when a smaller Padlock is required.</p>
 <p>VPI-2 530MT5+ Key in Knob/Lever cylinder to suit Lockwood 530 and 930 Locksets</p>	 <p>VPI-2 201MT5+ Round cylinder to suit most night-latches</p>
 <p>VPI-2 570 MT5+ Oval Cylinder for Lockwood 3570 series, Mortice locks</p>	 <p>VPI-2 693MT5+ Cupboard/Draw Lock, to suit both latching and dead bolt requirements</p>
 <p>VPI-2 8474MT5+ Meter Box and Garage Door Lock</p>	 <p>VPI-2 EUROMT5+ fits most security door locks, both lazy and fixed cam available, and internal turn if needed, please nominate when ordering.</p>

**Figure 5.6-A Victorian Power Industry Locks Series 2**

- For electrical metering enclosure or cabinets, a CL001 Key lock may be used.



**Figure 5.6-B Electrical Metering Enclosure/Cabinet Lock (key code CL001)**

A2

**This page intentionally blank**

## 5.7 Private Electric Lines on Public Land

### 5.7.1 General

In accordance with Clauses 4.4.1.3 and 7.9 (Electrical Installations on Public Land), the relevant Distributor shall be contacted prior to installing an electrical installation and/or private electric line on public land, or extend wiring and equipment from an electrical installation into or across public land.

Unless a person or party has a Distribution Licence or an exemption from the need for a Distribution Licence, private electric lines installed in public land shall only be used to supply electricity to the customer responsible for those lines.

Responsibilities of existing private electric lines in public land shall be ascertained prior to work taking place on the line/s, and new and altered lines shall comply with these Rules.

### 5.7.2 Definitions

*public land*, in Division 4 of Part 3 and Part 8, of the Electricity Safety Act means—

- (a) Crown land; or
- (b) land vested in a Minister of the Crown; or
- (c) land vested in a public statutory authority or municipal council; or
- (d) land (whether privately or publicly owned) used for public purposes;

For the purposes of these Rules, Public Land includes areas such as public roads, and reserves associated with creeks, rivers and forests.

**Supply Authority** – includes the previous SECV, Electricity Services Victoria and Municipal Councils Electricity Suppliers, and the current electricity Distributors.

### 5.7.3 Legislation Summary

Prior to 1998 options for most parties other than supply authorities to install electric lines in public land were to:

- (a) Vest the lines to supply authorities; or
- (b) Obtain an Order in Council; or
- (c) Obtain exemption to the relevant Act

When introduced, the Electricity Safety Act enabled parties such as municipal councils, Vic Roads and the Public Transport Authority to install electric lines in public land for their own purpose. Other customers and parties had the same options as existed previously.

The Electricity Safety Act Order in Council gazetted on 24 January 2002 effectively enables most customers and parties not previously enabled by the Electricity Safety Act to install electric lines in public land under the Order's terms and conditions.

### 5.7.4 Responsibilities

**Vested Lines** – Existing private electric lines in public land may have been installed under an agreement to vest the private electric lines with the supply authority under the condition they were installed and maintained by the customer, and the customer providing an indemnity to the supply authority for any liability arising from the lines. These lines are the responsibility of the current customer or party responsible for the electrical installation supplied from that line.

**Orders in Council** - Existing private electric lines installed within public land under an Order in Council are the responsibility of the current customer or party responsible for the electrical installation supplied from that line.

**Exemptions to the relevant Act** - Existing private electric lines installed within public land under an exemption from the relevant Act are subject to the exemption conditions. Generally, these lines are the responsibility of the current customer or party responsible for the electrical installation supplied from that line.

## 5.7.5

### **Current Practices**

#### **(a) Parties enabled by the Act**

The introduction of the Electricity Safety Act effectively enables parties such as Municipal councils, bodies established under Part 2 of the Rail Corporations Act and the Roads Corporation to install private electric lines in public land.

#### **(b) Order In Council – Electric Lines on Public Land Exemption**

This Order gazetted on 24 January 2002 effectively enables persons as defined in the Order that are not enabled by the Act to install private electric lines on public land under the terms and conditions of the Order.

Persons exempted

The following persons are exempted from compliance with section 46 of the Electricity Safety Act in respect of the specified activities on the land specified:

- (a) a person who is responsible for the management of public land, for the purposes of the person's functions or powers under any Act, other than persons already excepted from the requirements of section 46 of the Electricity Safety Act by that section;
- (b) a person who is the owner or occupier of privately owned land used for public purposes, for the purpose of enabling the land to be used for public purposes;
- (c) a person who has entered a lease or licence of land or an agreement relating to land under the Land Act 1958 or the Crown Land (Reserves) Act 1978 for the purpose of carrying out activities on the land authorised under the lease, licence or agreement;
- (d) a person who is the holder of a nominated carrier declaration or a carrier licence, for the purpose of carrying out activities relating to a network unit referred to in the declaration or authorised under the licence;
- (e) the Link corporation or the Extension corporation, for the purpose of their functions or powers under any Act;
- (f) a person who, for private purposes, installs an electric line over or under public land in order to convey electricity to other land or property owned or leased by, or under the control of, that person;
- (g) a person who installs, or causes to be installed, an electric line on public land on behalf a persons exempted under paragraphs (a) to (f).

Terms and conditions of exemption

A person to whom this Order applies shall:

- (a) give to ESV details of the name, position, business address and telephone number of the person who has management or control of the electric line on public land and shall advise ESV of any change in that person's contact details within 14 days; and
- (b) have while this Order is in operation:



A3 |

- (i) the consent of the owner of any property that may be affected by the activities to which this Order relates; and
- (ii) unless inconsistent with any obligation of the distribution company under a licence under the Electricity Industry Act 2000, the consent of the distribution company to whose supply network the electric line is or is to be connected; and
- (c) in relation to an underground electric line, maintain a record of the electric line on public land in accordance with Electricity Safety (General) Regulations; and Victoria Government Gazette G 4 24 January 2002 129
- (d) give to ESV, within 14 days of completing the installation of the electric line on public land:
  - (i) in relation to an overhead electric line, sufficient information to enable the electric line to be located; or
  - (ii) in relation to an underground electric line, a description of how the person has complied with section 76(1)(b) of the Electricity Safety Act; and
- (e) upon the removal of the electric line on public land:
  - (i) in relation to an overhead electric line, give to ESV, within 14 days of the removal, sufficient information to enable ESV to identify the electric line removed; or
  - (ii) in relation to an underground electric line:
    - (A) give to the person or body informed under section 76(1)(b) of the Electricity Safety Act sufficient information to enable the person or body to identify the electric line removed; or
    - (B) give to ESV a description of how the person has complied with paragraph A; and
- (f) comply with any direction under section 141 of the Electricity Safety Act; and
- (g) give to ESV any further information that ESV requests in writing in relation to compliance with this Order; and
- (h) comply with a request under this Order within the time specified by ESV in the request.

Further information and guidance can be obtained from the ESV Website “Installation of Electric Lines on Public Land Guideline”

### 5.7.6 Recording of Private Electric Lines on Public Land

Section 76 of the Electricity Safety Act requires persons controlling private underground electric lines on public land to:

- Maintain a record of the line; and
- Other than lines that are part of a railway as defined in section 3 (1) of the Rail Safety Act, provide a diagram of the line to an asset recording body specified by ESV, or if no asset recording body is specified, to the relevant electricity Distributor before the line is connected to supply, or within 2 business days of relocating the line.

ESV has specified this requirement does not include Extra Low Voltage (ELV) lines, ie, lines with voltages not exceeding 50V a.c. or 120V ripple free d.c.

Therefore, except for lines controlled by specified asset recording bodies named above and ELV lines, the relevant Distributor shall be provided an accurate diagram of any

private electric underground line before the line is connected to supply, or within 2 business days of relocating the line.

## **5.8 Multiple Occupancy Buildings and Subdivisions (General)**

### **5.8.1 General**

**5.8.1.1** For the purpose of establishing acceptable electricity supply arrangements associated with multiple occupancy buildings or subdivisions, it is essential certain information is submitted to the relevant Distributor.

The aforementioned information shall include a copy of the proposed/final version of the Plan of Subdivision, or a plan of the Multiple Occupancy Building, the maximum demand of the electrical installation/s and any other information deemed necessary by the Distributor. Where the property comprises, a multiple occupancy building not intended to be subdivided, it is essential the common area is clearly marked on the plan for the purpose of determining the supply point and meter location/s.

In order to avoid unnecessary expenditure, it is important the relevant Distributor receives this information during the planning stage or as soon as a decision to proceed is finalised.

Persons responsible for electrical design or installation of wiring within multiple occupancy buildings or proposed/finalised subdivisions shall ensure the electrical design and wiring work is completed in accordance with these rules, the Electricity Safety Act and the Electricity Safety (General) Regulations.

**5.8.1.2** Specific requirements related to Multiple Occupancy Buildings and Subdivisions are contained in the following rules:

- clause 6.2 (Point of Supplies) and the definition of property and points of supply
- clause 6.3 (Consumer's Terminals)
- clause 7.10 (Multiple Occupancy Buildings) and Subdivisions (Supply Arrangements)
- clause 8.10.2 (Multiple Occupancy Buildings and Subdivisions) (Metering Arrangements)

Registered Electrical Contractors, Electrical Consultants, Licensed Electrical Inspectors or similarly qualified persons can assist with electrical designs and preparation of electricity supply applications.

A3 |

# Section 6

## Supply Types, Use and Protection

<b>Section 6 – Contents</b>		<b>Page</b>
<b>6.1</b>	<b>Network Supply</b>	<b>6-7</b>
6.1.1	Supply Systems	6-7
Table 6.1	Standard Nominal Voltages and Voltage Variations	6-7
6.1.2	Prospective Short Circuit Current	6-7
6.1.2.1	General	6-7
6.1.2.2	Low Voltage	6-7
6.1.2.3	High Voltage	6-8
<b>6.2</b>	<b>Point of Supply</b>	<b>6-8</b>
6.2.1	Property	6-8
6.2.2	Point of Supply	6-8
6.2.2.1	Definition	6-8
6.2.2.2	Provision	6-9
6.2.2.3	Location	6-10
Table 6.2-1	Point of Supply/Customer Terminals Location	6-10
<b>6.3</b>	<b>Consumer's Terminals</b>	<b>6-10</b>
6.3.1	Definition	6-10
6.3.2	Number of Consumer's Terminals per Point of Supply	6-11
6.3.3	Identification of Consumer's Terminals	6-11
<b>6.4</b>	<b>Supply Arrangement Diagrams</b>	<b>6-11</b>
<b>6.5</b>	<b>Supply Use Obligations</b>	<b>6-11</b>
6.5.1	General	6-11
6.5.2	Non Compliance	6-12
6.5.3	Switched Loads	6-12
6.5.4	Voltage Drop	6-12
6.5.5	Equipment Requiring Special Consideration	6-12
6.5.6	Starting Current of Motors	6-12
6.5.6.1	General	6-12
6.5.6.2	Three Phase Motors	6-13
Table 6.5-1	Three Phase Motors	6-13
6.5.6.3	Single Phase Motors	6-13
Table 6.5-2	Single Phase Motors	6-13
6.5.7	Test Method for Measurement of Motor Starting Current	6-14
6.5.7.1	Fall in Voltage Method	6-14
6.5.7.2	Current Measurement Method	6-14
6.5.8	Back Feed	6-14
<b>6.6</b>	<b>Type of Supply and Load</b>	<b>6-14</b>
<b>6.7</b>	<b>Supply Capacity (Maximum Demand Limitation)</b>	<b>6-15</b>

A3

<b>Section 6 – Contents</b>	<b>Page</b>	
6.7.1	Application	6-15
6.7.1.1	Electrical Installations Subject to a Demand Agreement/contract	6-15
6.7.1.2	Electrical Installations Subject to a Specific Electricity Distribution Connection Agreement, Contract or a Deemed Electricity Distribution Contract	6-15
6.7.1.2.1	New Electrical Installations	6-15
6.7.1.2.2	Existing Electrical Installations	6-15
6.7.2	Maximum Demand by Limitation	6-16
6.7.2.1	General	6-16
6.7.2.2	Maximum Demand Limitation Device/s	6-16
<b>6.8</b>	<b>Installation &amp; Supply Protection</b>	<b>6-16</b>
6.8.1.1	Additional Installation Protection	6-16
6.8.1.2	Supply Protection	6-16
6.8.2	Assemblies to Accommodate LV Supply Protection Devices (SPD)	6-17
6.8.2.1	General	6-17
6.8.2.2	Access	6-17
6.8.2.3	SPD and Assembly Selection	6-17
6.8.2.4	Common Enclosures	6-17
6.8.2.5	Labelling	6-18
6.8.3	Security of SPD and Assembly	6-18
6.8.3.1	General	6-18
6.8.3.2	Identification, Sealing & Locking Facilities	6-18
6.8.4	Operation	6-18
6.8.4.1	General	6-18
6.8.4.2	Emergency Services Personnel	6-18
6.8.4.3	Licensed Electrical Workers	6-19
6.8.5	Specifications	6-19
6.8.5.1	SPD's and Assemblies – General Requirements	6-19
6.8.5.2	Pole Mounted Circuit Breakers	6-20
6.8.5.3	Fuses	6-20
6.8.5.3.1	Cartridges	6-20
6.8.5.3.2	Supply Protection Assembly Types (SPA)	6-20
6.8.5.3.2 (a)	Fused Overhead Line Connector Boxes	6-20
6.8.5.3.2 (b)	Panel Mounted Fuses	6-20
6.8.5.3.2 (c)	Fused Switch Disconnecter (FSD)	6-21
6.8.5.3.3	Prohibited Fuse Assemblies	6-21
Figure 6.8-A	Prohibited Panel Mounted Fuse	6-21

A3

<b>Section 6 – Contents</b>		<b>Page</b>
6.8.5.3.4	Acceptable Fuse Assemblies and Fuse Cartridges	6-21
Figure 6.8-B	Acceptable Supply Protection Devices and Assemblies	6-21
6.8.6	SPD – Specific Type & Use	6-22
<b>6.9</b>	<b>Alternative and Supplementary Supplies</b>	<b>6-22</b>
6.9.1	General	6-22
6.9.2	Generator Classification	6-23
6.9.2.1	Stand-alone Generator (Normal Supply)	6-23
6.9.2.2	Standby Generator (Alternative Supply)	6-23
6.9.2.3	Embedded Generator (Supplementary Supply)	6-23
6.9.3	Connection and Technical Requirements	6-23
6.9.3.1	General	6-23
6.9.3.2	Stand Alone (Normal Supply)	6-23
6.9.3.3	Standby Generator (Alternative Supply)	6-23
6.9.3.4	Notification and Application	6-23
6.9.3.5	Technical	6-24
6.9.3.6	Embedded Generator (Supplementary Supply)	6-24
6.9.3.7	Inverter Energy Systems	6-24
6.9.3.8	Notification	6-24
6.9.3.9	Technical	6-24
6.9.3.10	Product	6-24
6.9.3.11	Inverter Protection Settings	6-24
6.9.3.12	Installation	6-24
6.9.3.13	Isolation	6-24
6.9.3.14	Control and Protection	6-24
6.9.4.15	Voltage Rise Requirements	6-24
6.9.3.16	Labelling	6-25
6.9.3.17	Location	6-25
6.9.3.18	Specification and Configuration	6-25
6.9.3.19	Central Voltage and Frequency Protection	6-25
6.9.3.19.1	General	6-25
6.9.3.19.2	Central Voltage and Frequency Protection Requirements:	6-25
6.9.3.19.2.1	Export Control	6-26
6.9.4	Battery Energy Storage Systems (BESS) (Alternative or Supplementary Supply)	6-26
6.9.4.1	Alternative Supply	6-26
6.9.4.2	Supplementary Supply	6-26
6.9.5	Certification and Commissioning	6-26
6.9.6	Standby Generation	6-27

A3

<b>Section 6 – Contents</b>		<b>Page</b>
6.9.6.1	General	6-27
6.9.6.2	Standby Synchronous Generator	6-27
6.9.6.3	Break Before Make System	6-28
6.9.6.4	Uninterruptible Power Supply (UPS) System	6-28
6.9.6.4 (a)	Maximum Parallel Time Between UPS Inverter and the Distribution Network	6-28
6.9.6.4 (b)	Maximum UPS Inverter Output Rating Without Distributor Consultation	6-28
6.9.6.4.1	Generation With 'Make Before Break' Transfer Switching	6-28
6.9.7	All Other Forms of Embedded Generation	6-29
6.9.8	Embedded Generation Metering	6-30
6.9.8.1	Bidirectional Metering	6-30
6.9.8.2	Electricity Tariff	6-30
<b>6.10</b>	<b>Un-metered Supplies</b>	<b>6-31</b>
6.10.1	General	6-31
6.10.2	Eligibility	6-31
6.10.2.1	Eligible	6-31
6.10.2.2	Ineligible	6-31
6.10.2.3	Classification	6-32
6.10.3	Connection requirements	6-32
6.10.3.1	Connection process	6-32
6.10.3.1.1	Approval	6-32
6.10.3.1.2	Connection	6-33
6.10.3.2	Facility Access Agreement	6-33
6.10.4	Technical requirements	6-33
6.10.4.1	Electrical installation	6-33
6.10.4.1.1	General	6-33
6.10.4.1.2	Compliance	6-33
6.10.4.1.3	Maintenance	6-34
6.10.4.1.3.1	Tests	6-34
6.10.4.1.3.2	Frequency	6-34
6.10.4.1.3.3	Reporting	6-34
6.10.4.1.4	Alteration to installation	6-34
6.10.4.1.4.1	Configuration	6-34
6.10.4.1.4.2	Load	6-35
6.10.4.1.5	Removal of connection	6-35
6.10.4.2	Distributor – Technical requirements	6-35
6.10.4.2.1	Point of Supply	6-35
6.10.4.2.1.1	Pole	6-35
6.10.4.2.1.2	Underground	6-35

A3

	<b>Section 6 – Contents</b>	<b>Page</b>
A3	6.10.4.2.2 Private electric cable routes	6-36
	6.10.4.2.3 Attachments	6-36
	6.10.4.2.3.1 Pole	6-36
	6.10.4.2.3.2 Concrete and Steel (conductive)	6-36
	6.10.4.2.4 Safety	6-37
	6.10.4.2.5 Protection & Maximum Demand Limitation	6-37
	6.10.4.2.6 Labelling	6-37
	6.10.4.2.7 Earthing	6-37
	6.10.4.2.8 Multiple connections	6-37
	6.10.5 Supplies in public land	6-37
	6.10.5.1 ESV - exemption	6-37
	6.10.5.2 Route plans	6-38



## 6.1 Network Supply

### 6.1.1 Supply Systems

Electricity supplied throughout Victoria is in the form of alternating current of approximately sinusoidal waveform at a frequency of 50 Hz. Electricity Distributors' endeavour to maintain the voltage at the Point of Supply in accordance with the Electricity Distribution Code of Practice (Refer Table 6.1-1) and the Code and may superimpose control signals on the normal supply voltage.

Standard nominal voltages are 230 V, 400 V, 460 V, 6.6 kV, 11 kV, 22 kV and 66 kV.

Standard Low Voltage Systems are 3 phase 4 wire 400/230 V, Single phase 2 wire 230 V and 3 wire 460/230V Systems.

**Table 6.1-1 Standard Nominal Voltages and Voltage Variations**

STANDARD NOMINAL VOLTAGE VARIATIONS					
	Voltage Level in kV	Voltage Range for Time Periods			Impulse Voltage
		Steady State	Less than 1 minute	Less than 10 seconds	
1	< 1.0	AS 61000.3.100*			6 kV peak
2		+ 10% - 6 %	+ 13% - 10%	Phase to Earth +50%. -100% Phase to Phase +20%. -100%	
3	1 – 6.6	± 6 %	± 10%	Phase to Earth +80%. -100% Phase to Phase +20%. -100%	60 kV peak
4	11	(±10% Rural Areas)			95 kV peak
5	22				150 kV peak
6	66	± 10%	± 15%	Phase to Earth +50%. -100% Phase to Phase +20%. -100%	325 kV peak

\* The voltage range for time periods less than 1 minute and 10 seconds do not apply to AS 61000.3.100.

### 6.1.2 Prospective Short Circuit Current

#### 6.1.2.1 General

The Wiring Rules require electrical installations to be designed with consideration to the prospective short-circuit current under short circuit conditions within the electrical installation.

For the purpose of this clause a bolted short circuit means a fault of negligible impedance at the point of short circuit.

Dependent upon the relative location of the electrical installation's connection to the electrical distribution system the prospective short-circuit current at the consumer's terminals will vary. This variance is due to the electrical distribution system characteristics such as size and impedance of the transformer and impedance of cables supplying the consumer's terminals.

#### 6.1.2.2 Low Voltage

For electrical installations connected to low voltage supply, except as provided for below, the prospective short-circuit current at the consumer's terminals shall be deemed to be 6 kA phase to earth and 10 kA between phases.

Higher prospective short-circuit current values apply to consumer's terminals close to transformers of a capacity of 500 kVA and from transformers of greater capacity. In these

cases, the relevant Distributor should be contacted to provide the actual prospective short-circuit current value and its duration at the particular location.

Lower prospective short-circuit current values than the 6 kA and 10 kA stated above may apply in some locations where the supply arrangements are not expected to change for the anticipated lifespan of the installation. In these cases, where the 6 kA and 10 kA values are not adopted, and also, where the prospective short-circuit current value at a particular electrical installation's location is uncertain, the relevant Distributor should be contacted in accordance with the details in Section 3 to provide the prospective short-circuit current.

### 6.1.2.3 High Voltage

Details of prospective short-circuit currents and their duration relating to high voltage installations can be obtained from the Distributor.

## 6.2 Point of Supply (refer to **Technical Information on the Website for Property** the rewritten Clause 6.2 and sub-clauses)

### 6.2.1

The Consumer's mains must not enter or cross any property that is contiguous to the property the consumer's mains supplies.

For the purpose of these Rules "Property" means land on which the single electricity customer or controlling body or their representatives have the right to install their electrical installation.

A property may include:

- (a) a single parcel of freehold, leasehold and/or public land which may include land held under lease or licence on which the customer or controlling body has the right to install their electrical installation;
- (b) any combination of contiguous land to which the customer or controlling body has the right to install their electrical installation; and
- (c) contiguous land and/or individual titles to which a corporate body, customer and or controlling body has the right to install their electrical installation.

An expressed easement through adjacent property to which the customer or controlling body does not have occupancy rights is not considered to form part of a property for the purpose of the establishment of a Point of Supply.

In the event that the boundary of the property to be supplied is not clearly defined, the prospective customer shall be responsible to physically and accurately define the boundary of the property to the satisfaction of the Responsible Officer.

Where supply has been provided to a property that comprises of contiguous land and the electrical installation and/or occupancies wiring extend into or across property the customer or controlling body will not have rights, shall upon the land becoming non-contiguous re-arrange the supply to comply with these Rules and the Electricity Safety Act and Regulations.

## 6.2.2 Point of Supply

### 6.2.2.1 Definition

**Point of Supply (POS)** – the point at which the electricity Distributors service cable or supply main connects to the consumer's terminals. (Refer Section 1 – Definitions)

### 6.2.2.2 Provision

The Distributor, following application in accordance with clause 4.4 (Application for Supply Availability), and during negotiations for supply, will nominate the location and provide one point of supply for each property.

Provided it is not necessary for the Distributor to undertake unreasonable augmentation of the network to provide an additional point of supply, more than one point of supply may be provided to a property in the following circumstances;

- (a) Multiple Occupancy;
- (i) comprising separate individual structures intended to be occupied by different customers and does not include any common area; and
  - (ii) the land associated with each of the structures directly abuts a public road reserve or a Distributor's easement; and
  - (iii) the land owner is prepared to submit a draft plan of subdivision, to the Distributor, verifying any future subdivision of the land will not incorporate common property;

*Note: A draft plan of sub division is considered to be a fully dimensioned plan, professionally prepared by an architect or surveyor and submitted on the letter head of a registered business*

- (b) Subdivisions

Refer to clause 7.10.3 Subdivisions Incorporating Common Property and 7.10.4 Subdivisions Not Incorporating Common Property.

- (c) Subject to Approval by the Relevant Distributor;

Where the magnitude of the customers' electrical load and/or distance, separating the relevant electrical installations are such that it would be sound engineering practice to provide more than one point of supply. Examples of situations where sound engineering practice is a consideration are;

- (i) load;
  - where the supply capacity cannot be supported by a single substation located within the property; or
- (ii) distance;
  - where it is impractical to supply the relevant load using a low voltage sub-main or final sub-circuit originating at the primary electrical installation.

#### **NOTE:**

A 'service cable' will not be provided where a substation is located on the customer's property as the customer is responsible for all wiring up to the substation LV consumer's terminals'.

#### **Key Considerations;**

Segregation of Supplies – Earthing

Multiple Earthed Neutral (MEN) – Separate Supplies

Earthing of Multiple Installations

A2

A1

A3

Where it is proposed to cross a major asset of another Authority within the customer's property, the customer shall consult with that Authority and the relevant Distributor regarding the requirements of the other Authority or an alternative means of providing supply to the property.

Examples of major assets may be, but are not restricted to: gas pipelines, water mains, oil pipelines, sewerage pipelines/channels, waterways, irrigation channels, across distribution company easements, telecommunication assets etc

### 6.2.2.3 Location

In all cases the Distributor reserves the right to determine the method of supply and where the point of supply will be located.

The following are points of supply and consumer's terminals location relative to the type of supply.

Refer to Clauses 7.3.2.4 (Underground Supplies-Consumer's Terminals) and 7.4.3 (Overhead Supplies-Consumer's Terminals) and Section 9 High Voltage Electrical Installations for specific details of POS and consumer's terminal arrangements for low and high voltage supplies.

**Table 6.2-1 Point of Supply/Consumer's Terminals Location**

SUPPLY TYPE	POINT OF SUPPLY/CONSUMER'S TERMINALS LOCATION
<b>AERIAL SERVICE CABLE</b>	Within 500 mm of the first point of the service cable attachment within the property or on the premises, refer to Figure 7.4-B.
<b>UNDERGROUND</b>	
<b>Supply pit</b>	In the pit, adjacent the property
<b>Supply cable</b>	Within a connection facility at, or with the Distributor's agreement, a short distance from the property boundary. refer clause 7.3.2.2 Location
<b>Ground, Kiosk &amp; Indoor Type Substation on property</b>	As nominated by the Distributor – Normally at the Substation LV consumer's terminals'
<b>Pole &amp; Pole Type Substation</b>	As nominated by the Distributor – normally 4m from ground level.
<b>High Voltage</b>	The point agreed between the relevant Distributor and Customer

A1

## 6.3 Consumer's Terminals

In all cases the Distributor reserves the right to determine the method of supply and where the Consumer's Terminals will be located, and may require the customer to arrange facilities for the installation of the service cable and conduits at the customer's expense.

### 6.3.1 Definition

**Consumer's Terminals** - means the electrical junction at which the Distributor cable or supply conductors connect to the customer's installation or consumer's mains within the customer's property.

### 6.3.2 Number of Consumer's Terminals per Point of Supply

No more than one set of consumer's terminals shall be connected to a point of supply.

Only under exceptional circumstances and where no practical engineering solution is available the relevant Distributor may agree to a customer's request for the connection of more than one set of consumer's terminals to a point of supply.

### 6.3.3 Identification of Consumer's Terminals

Consumer's terminals shall be labelled adjacent to the terminals in accordance with Clause 5.4 (Labelling) to identify the electrical installation they supply in the following circumstances:

- Where more than one set of consumer's terminals are supplied from a common point of supply; and
- Where the consumer's terminals are located within a supply pit.

## 6.4 Supply Arrangement Diagrams

A3 |

In addition to the requirements of the Electricity Safety Act and Electricity Safety (General) Regulations the following Rules apply where, in accordance with the provisions of Clause 6.2.2 (Point of Supply):

- more than one point of supply is provided to a property and/or more than one set of consumer's terminals are connected to a point of supply; and
- there is a risk of incorrect identification of:
  - the property's supply arrangements; and
  - segregation between the electrical installations and occupancies un-metered wiring, switchboards and metering.

The supply arrangement diagrams shall be permanent, indelible, legible and incorporate accurate dimensions. The diagrams shall indicate the location of the point of supply for each electrical installation, the un-metered consumer's mains/submains, metering points and main switchboards.

Where multiple meter locations are connected to an electrical installation the diagram installed at that location shall identify the supply point and wiring supplying the meter position, and the location of the occupancy switchboards supplied from that meter position.

The location and condition of operation of any alternative source of supply to the electrical installation shall also be shown.

The customer is responsible for the provision and maintenance of the diagrams and to ensure they are permanent, legible and up to date at all times.

## 6.5 Supply Use Obligations

### 6.5.1 General

At the time of publication of these rules the Electricity Distribution Code included obligations for customers to use best endeavours to ensure:

- (a) protection equipment in the customer's electrical installation, is at all times effectively co-ordinated with the electrical characteristics of the distribution system; and
- (b) ensure that the distribution system and the reliability and quality of supply to other customers are not adversely affected by the customer's actions or equipment.

The Electricity Distribution Code should be referenced for specific details related to Power Factor, Harmonics, Load Balance and Disturbing Loads.

The Wiring Rules also has a requirement for electrical equipment not to cause adverse effects and interference (such as harmonics) to other equipment.

## **6.5.2 Non-Compliance**

If, in the opinion of the Electricity Distributor, a person should use or deal with electricity supplied in such a manner as to cause undue interference with the supply to other customers or to any third party, the Distributor may direct the customer to take corrective action and, in the event of failure to comply with such directions, the Distributor may discontinue the supply of electricity to the electrical installation or occupancy.

The fact that the Distributor may have permitted connection of the apparatus or equipment causing the interference shall not exempt the customer from the application of this Clause.

## **6.5.3 Switched Loads**

To meet the specifications regarding balance of current in three phase installations and disturbing customer equipment the following advice may assist:

In many electrical installations, individually switched loads including embedded generation switched loads, rated in excess of the value specified below, should not be connected between an active and the neutral conductor.

- Single Phase or SWER 460/230 Volt areas of supply – 20 Amperes
- Three Phase 400/230 Volt areas of supply – 25 Amperes

## **6.5.4 Voltage Drop**

The Wiring Rules specify the allowable voltage drop within an electrical installation.

## **6.5.5 Equipment Requiring Special Consideration**

The relevant Distributor may refuse to permit or apply conditions and/or tests for the connection of equipment in the following categories if it considers that by such connection, the supply to other customers would be adversely affected –

- (a) Equipment which could cause excessive fluctuation of voltage on the Distributor's system as a result of its large or fluctuating demand, e.g. Non-linear load control such as variable speed motors, gas discharge lighting, arc furnaces, welding machines, X-ray units, frequently-started large motors, etc.
- (b) Equipment which could cause excessive distortion of the wave shape of the Distributor's system voltage, e.g. rectifiers, frequency converters, load control devices using thyristors or saturable reactors, etc.

No expense should be incurred by any customer or prospective customer until an application has been made to the relevant Distributor and advice has been received that the supply will be given and upon what terms and conditions it will be given.

## **6.5.6 Starting Current of Motors**

### **6.5.6.1 General**

The current taken by a motor of a type mentioned in this Clause under the conditions of starting shall not exceed the values in Table 6.5-1 and Table 6.5-2 when measured by the methods outlined in Clause 6.5.7 (Test Method of Measurement of Motor Starting Current).

### 6.5.6.2 Three Phase Motors

The kW output of motors installed refers to the motors connected to the particular electrical installation from which the proposed motor is to be supplied and includes the proposed motor, provided that no limitation need be placed on the starting current of any three phase motor which is not frequently started and the rating of which does not exceed 10 per cent of the total motor load installed.

In electrical installations, which are supplied directly from a substation or where special supply conditions exist, starting currents in excess of those set out in Table 6.5-1 sections (b) and (c) may be permitted if permission has been obtained from the Responsible Officer.

**Table 6.5-1 Three Phase Motors**

MOTOR SIZE	ALLOWABLE CURRENT – I
not exceeding 1.5 Kw	$I = 26$ Amperes
exceeding 1.5 kW, but not exceeding 3.75 kW	$I = (\text{kW} \times 17.5)$ Amperes
exceeding 3.75 kW	(a) $I = (\text{kW} \times 3.5) + 53$ Amperes, or
	(b) $I = \text{total kW of motors installed} \times 1.1$ Amperes, or
	(c) $I = \text{the starting current of the largest of the other motors installed calculated in accordance with sub-clause (a), whichever is the greatest.}$

### 6.5.6.3 Single Phase Motors

**Table 6.5-2 Single Phase Motors**

MOTOR VOLTAGE	MOTOR SIZE	ALLOWABLE CURRENT – I
230 Volts	All sizes	$I = 45$ Amperes
460 Volts	Not exceeding 1.5 kW	$I = 45$ Amperes
	Exceeding 1.5 kW, But not exceeding 3.75 kW	$I = (\text{kW} \times 9.5) + 26$ Amperes
	Exceeding 3.75 kW, But not exceeding 30 kW	$I = (\text{kW} \times 6.5) + 35$ Amperes
	Exceeding 30 kW	$I = (\text{kW} \times 7.4) + 15$ Amperes

## **6.5.7 Test Method for Measurement of Motor Starting Current**

The starting currents of alternating current motors shall be determined by either of the following methods –

### **6.5.7.1 Fall in Voltage Method**

The starting current shall not cause a fall in voltage of more than 5 per cent for more than 0.02 seconds when connected to a typical 400/230 volt, three phase, 50 Hz supply having a supply system impedance of –

- $0.2 + j 0.2$  ohms (phase–neutral)
- $0.1 + j 0.1$  ohms (line impedance per phase)

The fall in voltage shall be determined by the oscillographic method or any other method considered appropriate by the Distributor.

### **6.5.7.2 Current Measurement Method**

The starting current may be determined by the locked rotor method with low voltage, 50 Hz, as appropriate, applied to the terminals of the motor. In the case of motors having rotors which cannot readily be locked, the current may be measured using an ammeter with hold function to record current value or by any other approved method.

## **6.5.8 Back Feed**

Except as permitted by Clause 6.9 (Sources of Alternative Supplies), where a potential exists within an electrical installation to cause current flow or earth potential rise by back-feeding through the electrical installations equipment into the electricity supply system all necessary steps shall be taken to prevent any back feed into the supply system.

If this potential exists, the customer shall provide in the application for supply, details regarding how it proposes to prevent the occurrence of back-feeding.

## **6.6 Type of Supply and Load**

The applicable supply contract or agreement referred to in Clause 4.1 (Conditions of Supply) specifies:

- the conditions for connection of the electrical installation to the electricity network;
- the type of supply including the voltage and number of phases; and
- the allocated supply capacity where this is applicable.

Except for electrical installations subject to a deemed electricity distribution contract, the conditions for connection, the type of voltage and number of phases and supply capacity, that is, the allocated maximum demand or the allocated supply capacity can be determined from the customer's copy of the contract or agreement applicable to the electrical installation.

The relevant Distributor should be contacted as detailed in Section 3 (Distributor Areas and Contact Details) of this document to determine the supply arrangements where a customer does not have a specific electricity distribution connection agreement or contract or demand tariff agreement available and where a deemed electricity distribution contract applies.

The electrical installation loading shall be in accordance with the contract applicable to the electrical installation and arranged to comply with these Rules.



## 6.7 Supply Capacity (Maximum Demand Limitation)

### 6.7.1 Application

A3

Unless otherwise required by the relevant Distributor, maximum demand of electrical installations specified in this clause shall be controlled in accordance with SIR clause 6.7.2 and the Electricity Safety (General) Regulations, and in particular regulation 301 in relation to Safety Services.

#### 6.7.1.1 Electrical Installations Subject to a Demand Agreement/contract

Electrical installations in this situation include:

- all new electrical installations and existing electrical installations where the Distributor has specified in writing that the supply capacity be controlled; or
- installations that are subject to a contract that specifies an allocated maximum demand, shall also be controlled so as not to exceed the allocated maximum demand.

#### 6.7.1.2 Electrical Installations Subject to a Specific Electricity Distribution Connection Agreement, Contract or a Deemed Electricity Distribution Contract

Electrical installations in this situation shall be arranged in accordance with the Wiring Rules so as not to exceed 130% of the Distributors nominated supply capacity for more than 2 hours by one of the following means:

A3

- Circuit breakers complying to IEC/AS 60947 with a fixed thermal trip unit setting of 130% of the rated current of the circuit breaker. These may be MCCB's or MCB's
- Circuit breaker complying to IEC/AS 60898 with a fixed thermal trip unit setting of 145% of the rated current of the circuit breaker. These circuit breakers shall be de-rated to achieve 130% of the nominated supply capacity.

Adjustable circuit breakers are acceptable provided the thermal trip unit is set to a level equal to the nominated supply capacity and the overload duration is set as agreed with the Distributor.

##### 6.7.1.2.1 New Electrical Installations, where:

For Electrical Installations subject to a specific electricity distribution connection agreement, contract, or a deemed electricity distribution contract the following specific conditions will apply to maximum demand control:

- (a) The Distributor has specified that the supply capacity be controlled; or
- (b) The Distributor has determined that the nature of electricity use within the electrical installation may interfere with the reliability or quality of supply to other customers, and the Distributor has specified a maximum demand by limitation in order to reduce or eliminate the interference; or
- (c) The maximum demand as determined under the Wiring Rules exceeds 100Amps per phase; or
- (d) The electricity supply is not metered.

##### 6.7.1.2.2 Existing Electrical Installations, where:

- (a) The Distributor has specified that the supply capacity be controlled; or
- (b) The Distributor has determined that the nature of electricity use within the electrical installation may interfere with the reliability or quality of supply to other customers, and the Distributor has specified a maximum demand by limitation in order to reduce or eliminate the interference; or

- (c) Alterations or additions to the existing installation where;
- (i) The electrical installations calculated maximum demand as determined under the Wiring Rules exceeds 100 Amps per phase; or
  - (ii) The electricity supply is not metered.

## 6.7.2 Maximum Demand by Limitation

### 6.7.2.1 General

A device or devices other than fuse cartridges shall control the supply capacity to electrical installations specified in clause 6.7.1 (Application).

### 6.7.2.2 Maximum Demand Limitation Device/s

Circuit breaker/s utilised to limit the maximum demand shall:

- be installed on the main switchboard in accordance with the Electricity Safety Act and Regulations, the Wiring Rules, and these Rules;
  - be arranged to ensure the circuit breaker or the aggregate rating of multiple circuit breakers does not exceed the supply capacity; or
  - an alternative method with the agreement of the relevant Distributor; and
  - incorporate a sealing facility to secure the settings of an adjustable circuit breaker by the use of a Distributor seal or equivalent means where applicable.
- A1 |
- be located no higher than 2 metres above finished ground / floor level and be ‘readily accessible’.
- A3 |
- For switchboards exceeding 125A r.m.s per phase the nominated supply capacity shall be labeled in Amps on the switchboard in accordance with Clause 5.4 (Labelling).

NOTE: Refer to clause 8.8.1 (Direct Connected Meter-Limits of Current Carrying Capacity).

## 6.8 Installation & Supply Protection

### 6.8.1.1 Additional Installation Protection

Customers are advised to install supplementary protective equipment to limit possible damage to their electrical installation in the event of voltage variation, transients, and loss of one or more phases of supply or due to leakage current, eg, switchboard internal arcing fault. Customers should also ensure discrimination between the Distributors and the customer’s protective equipment in the event of an over-current situation on the customer’s installation.

Note; Refer to Clause 6.5 (Supply Use Obligations) and the Electricity Distribution Code.

### 6.8.1.2 Supply Protection

The Electricity Safety Act requires service lines to be protected by protective equipment that can isolate each of the active conductors of an electrical installation and prescribes their location.

A3 | The customer shall install and maintain an assembly to accommodate “supply protection device/s” (SPD) in accordance with the Electricity Safety (General) Regulations, these Rules and the obligations of the Distributor to connect and disconnect electrical installations.

A3 | In the case of electricity supplies provided directly from a substation on a customer’s property, the Distributors will provide the supply protection equipment within the substation. Note; *Exception. Pole type substations located on customer’s property; Refer to Table 7.5-2.*

A1 |

The installed SPD shall:

- (a) minimise any adverse conditions which may affect other customer's electrical installations and the distribution system. The SPD shall ensure adequate protection is provided up to the electrical protective equipment of the electrical installations they supply.

Note: In some cases, Distributors may utilise their HV protection equipment for supply protection. It will be necessary to confirm the supply protection arrangement with the relevant Distributor at the design stage of the electrical installation.

- (b) enable the Distributor to connect, disconnect and isolate each active conductor supplying the electrical installation for commercial and/or safety reasons; and
- (c) not exceed one device per phase

Refer to Supply Protection tables 7.2-1, 7.3-2, 7.4-3 and 7.5-2.

## **6.8.2 Assemblies to Accommodate LV Supply Protection Devices (SPD)**

### **6.8.2.1 General**

The customer is responsible for the provision of an assembly to accommodate supply protective device/s (SPD) provided by the Distributor. This equipment shall be of an acceptable type as required by these Rules and shall be located and installed in accordance with the relevant requirements of the current Electricity Safety Act and Regulations.

### **6.8.2.2 Access**

The assembly for the purpose of accommodating the SPD shall be installed in a position where convenient and unhindered access is readily available for the Distributor to safely operate and work on the device/s at all hours, unless otherwise agreed by the Distributor.

Access to SPD/s and their assemblies fitted at the termination of overhead service lines, shall be arranged to permit safe and ready operation by means of a low voltage operating stick from ground level in accordance with Clause 7.4.4.4.2 (POA Access) and Clause 7.4.4.4.3 (POA Location).

Should access to SPD/s and the assembly be impeded, arrangements shall be made for the restoration of unobstructed access at the customer's expense.

Delays may be experienced with connection or restoration of supply where access to the SPD and assembly is not readily available.

### **6.8.2.3 SPD and Assembly Selection**

Where a multiphase supply is provided, the SPD and assembly may be of a type which opens all phases simultaneously or opens each phase individually.

### **6.8.2.4 Common Enclosures**

The electrical wiring and SPD/s and the assemblies may be installed in a common enclosure with other electrical installation wiring and equipment provided the electrical equipment terminals having a minimum degree of protection of IP2X. Where IP2X degree of protection cannot be achieved then the SPD/s shall be segregated by barriers from other electrical equipment.

Provision shall be made to work on other electrical installation equipment without the need to disturb the SPD/s and the assembly connections in any way. Measures provided for locking the SPD assembly shall be arranged to permit such locking without the need to disturb other electrical installation equipment.

Refer to Cl 6.8.5.3.2(c) Fused Switch Disconnecter.

A3

### **6.8.2.5 Labelling**

A label containing the words “Supply Protection Device” shall be installed at or adjacent to the SPD enclosure provided by the customer. This requirement is not intended to apply to Supply Protection Devices contained within a FOLCB or on a meter panel.

## **6.8.3 Security of SPD and Assembly**

### **6.8.3.1 General**

SPDs and the assemblies shall be located and arranged to limit the ability of non Distributor personnel to interfere with and/or operate the assemblies and the associated devices.

An acceptable method to restrict unauthorised interference is to locate the SPDs and assemblies within an enclosure fitted with facilities to accommodate a Distributor’s lock or seal. This requirement need not apply to SPDs and the assemblies associated with an overhead service cable or supplies originating from a Distributor’s substation.

### **6.8.3.2 Identification, Sealing & Locking Facilities**

Where a supply protection assembly is located within a switchboard, any door/cover shall be arranged to provide unhindered access and shall be prominently and permanently marked to indicate the SPD is contained within.

SPDs and the assemblies required to be locked or sealed shall be capable of being secured by the Distributor.

Where the SPDs and the assemblies are to be secured by means of a lock, the locking facility shall be capable of accepting a Distributor’s padlock having a minimum 5.5 mm shackle 6 mm hole.

SPDs, other than those incorporated in an overhead line connector box, shall be provided with facilities to enable a Distributor’s seal to seal the assembly at all times.

## **6.8.4 Operation**

### **6.8.4.1 General**

SPD’s shall be supplied and installed by the relevant Distributor unless otherwise specified in these Rules or agreed with the Responsible Officer.

SPD/s and the assemblies shall only be operated by:

- (a) Persons authorised by the relevant Distributor; or
- (b) Authorised emergency services personnel whilst carrying out their duties.

### **6.8.4.2 Emergency Services Personnel**

Emergency services personnel should only operate SPD/s and the assemblies if they are so authorised by their organisation.

Where the SPD and the assembly are operated by emergency service personnel, it should only be operated to de-energise the electrical installation and shall not be operated to energise or re-energise the electrical installation.

Where emergency services personnel de-energise an electrical installation by operation of a SPD and the assembly, the customer (occupant) and relevant Distributor shall be advised at the earliest opportunity.

### 6.8.4.3 Licensed Electrical Workers

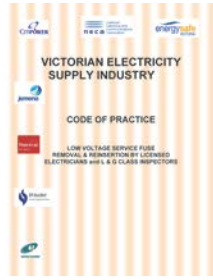

Persons eligible to operate SPD and the assembly under the VESI Code of Practice for Low Voltage Service Fuse Removal and Reinsertion by Licensed Electricians and L and G Class Inspectors, shall adhere to the conditions of that code.

The Code may be downloaded from Distributors, ESV and Victorian SIR web sites.

## 6.8.5 Specifications

### 6.8.5.1 SPD's and Assemblies – General Requirements

SPD/s and the assemblies shall:

- (a) be of a type acceptable to the Service and Installation Rules Management Committee or the relevant Distributor;
- (b) conform to the requirements of the appropriate Australian or International Standard for the type of device employed;
- (c) be installed in accordance with the requirements of the Electricity Safety Act, Regulations and these Guidelines;
- (d) be installed so as to comply with the minimum height requirement of consumer's terminals connected to the Distributor's service cables, refer to Figures 7.4-C and 7.4-D
- (e) be selected with regard to the following conditions, taking account of the nature of the supply (i.e. overhead, underground):
  - (i) operating environment;
  - (ii) enclosure of live parts;
  - (iii) short-circuit interrupting capacity;
  - (iv) ability to be manually operated, either directly by hand or by means of a standard low voltage operating stick from ground level;
  - (v) facilities for sealing or locking by the Distributor as required by these Rules;
  - (vi) termination compatibility with service conductors; and
  - (vii) provision of separate terminals for connection of service neutral conductor and the consumer's neutral conductor in an approved manner.
- (f) have a rated short circuit current capacity equal to or greater than the prospective short circuit current at the point it is installed;
- (g) have, or be installed with, facilities for sealing un-metered connections to prevent unauthorised access;
- (h) be maintained by the customer in accordance with the manufacturer's specifications.

### 6.8.5.2 Pole Mounted Circuit Breakers

Pole mounted circuit breakers shall comply with:

- AS/NZS 3124:2002 or a recognised equivalent standard; or
- AS/NZS 60898:2004 and the appropriate requirements of AS/NZS 3124; and

Shall be provided with:

- consumer's terminals;
- a means of operating the device by means of a low voltage fuse stick from ground level;
- sealing facilities to prevent access to consumer's terminals and to prevent operation of the device when it is locked off; and
- lock off facilities to accept a lock with a 5.5 mm diameter hasp.

### 6.8.5.3 Fuses

#### 6.8.5.3.1 Cartridges

All fuse cartridges shall be supplied by the Distributor.

Subject to approval by the relevant Distributor, Miniature Combined Fuse Switches may be used and are required to be provided by the customer and shall be supplied to AS/NZS 60269.3.1.

Fuse carrier assemblies rated at up to 100A shall be capable of accepting 22 mm barrel fuse cartridges of Type 2a, to AS/NZS 60269.2.1, or a recognised equivalent Standard.

Fuse carrier assemblies rated in excess of 100A shall be suitable for use with Din type NH blade fuse cartridges to AS/NZS 60269.2.1, or a recognised equivalent.

#### A2 | 6.8.5.3.2 Supply Protection Assembly Types (SPA)

##### 6.8.5.3.2 (a) Fused Overhead Line Connector Boxes

Fused overhead line connector boxes shall comply with AS/NZS 3124.

Fused overhead line connector boxes shall provide for manual operation by means of a low voltage operating stick from ground level and the cover shall be provided with sealing facilities.

##### 6.8.5.3.2 (b) Panel Mounted Fuses

Panel mounted fuse base and carrier's, shall be of a minimum continuous rating of 100 Amp, 500 Volt rating with a hand operated fuse carrier; and

- comply to AS/NZS 60269.2.1;
- have all live parts shrouded;
- be capable of being sealed using facilities cast into the base and carrier when the fuse carrier is inserted; and
- be back connected - Studs or front wired types are not acceptable.

Spacing, ventilation and de-rating of panel mounted fuses should be considered where subject to continuous loads exceeding 50 Amperes for periods greater than 2 hours.

### 6.8.5.3.2 (c) Fused Switch Disconnecter (FSD)

Fused Switch Disconnectors shall comply with AS 3947.3 and may be single or multiphase devices which accept DIN type HRC NH fuse cartridges.

Stick operated FSDs shall be suitable for mounting on either a pole or building facade and be capable of unhindered manual operation by means of a low voltage operating stick from ground level.

A2

Hand operated FSDs shall be suitable for mounting within the standard service connection facility and arranged in accordance with Table 7.3-1 Fig 7.3-B & Fig 7.3-C.

Where mounted on a customer's structure FSD's shall be so arranged that access to active parts (removal of cover) can only be gained with the use of a tool.

A3

Where an FSD is mounted within an assembly, (switchboard) then an escutcheon shall be provided to enclose any live parts, unless IP2X protection is provided, while still permitting the operation of the FSD without removing the escutcheon. Refer Cl 6.8.2.4 Common Enclosure.

### 6.8.5.3.3 Prohibited Fuse Assemblies

Stick Operated, Panel Mounted Fuse assemblies are a specific form of panel mounted fuse originally designed for mounting on a connection box mounted on the underside of a shop veranda.

These fuse assemblies are no longer acceptable for use as a Supply Protection Device or Occupancy Disconnection Device for new connections, and alterations or additions to existing electrical installations. This is due to live metallic parts being exposed when the carrier is removed.



Figure 6.8-A Prohibited Panel Mounted Fuse

### 6.8.5.3.4 Acceptable Fuse Assemblies and Fuse Cartridges

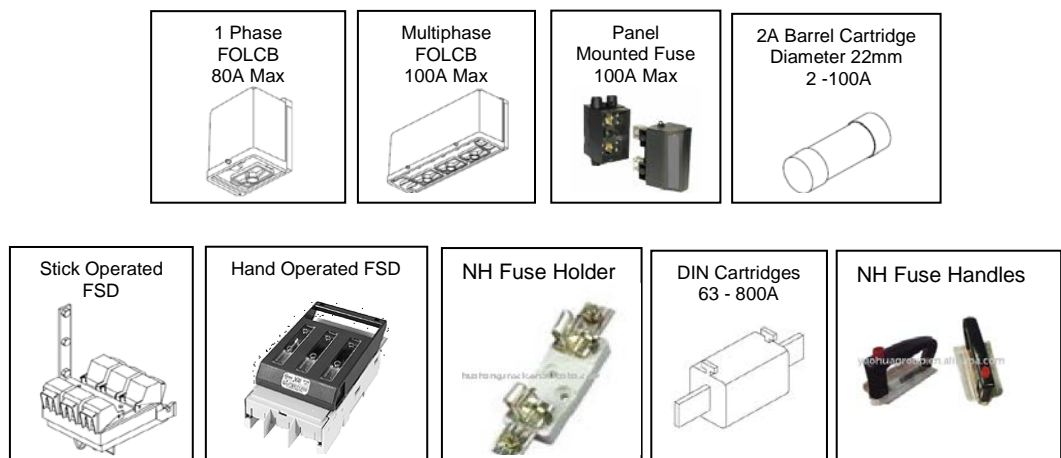

Figure 6.8-B Acceptable Supply Protection Devices and Assemblies

## 6.8.6 SPD – Specific Type & Use

The type of Supply Protection Devices and their use in any particular situation is dependent upon the type and supply arrangement to an electrical installation.

Specific types of Supply Protection Devices and their use are detailed in Section 7 of these Rules in the following tables:

Table 7.2-1 SPD – Supply from a Service Pit Connected to Underground or Overhead Distribution

Table 7.3-2 SPD – Supply from an Underground Service Cable Connected to Underground or Overhead Distribution

Table 7.4-3 SPD – Supply from an Overhead Aerial Service Cable

Table 7.5-2 SPD – Supply from an Indoor, Kiosk and Ground Type Substation located within the property it supplies

## 6.9 Alternative and Supplementary Supplies

### 6.9.1 General

Alternative or supplementary supplies are electricity supplies direct from generators or other equipment which provide an electricity supply not delivered by a Distribution Network. These supplies include embedded generators, standby generators, regenerative braking systems, inverter connected generators using various energy sources such as photovoltaic, wind or fuel cell, uninterruptible power supplies (UPS) and energy storage systems.

All alternative or supplementary supplies shall comply with The Electricity Safety Act and Regulations, Codes made under the Electrical Industry Act, Codes made under the National Electricity Rules, specific Generator Connection Standards issued by each Distributor, any relevant Australian Standards and these Rules. Relevant Australian standards include, but are not limited to, the following:

- (a) AS/NZS 3000 Australian / New Zealand wiring rules.
- (b) AS/NZS 3010 Electrical installation – Generating sets.
- (c) AS/NZS 4777 Series Grid connection of energy systems.
- (d) AS/NZS 3009 Electrical installations – Emergency power supplies in hospitals.
- (e) AS 62040 Uninterruptible power systems (UPS).
- (f) AS/NZS IEC 60947.6.1 Low-voltage switchgear and control gear Multiple function equipment - Transfer switching equipment
- (g) A host of additional standards are also applicable to components and sub systems including rotation machines, earthing, switchgear and fuses, transformers, cabling, labelling etc

Generally, all alternative or supplementary supplies shall:

- (h) Be arranged to disconnect from and not back energise the Distributor's network and service and metering equipment if electricity supply from the network is de-energised unless permitted by the Responsible Officer
- (i) Have electrical characteristics compatible with the relevant Distributor's network. The generator output shall not exceed the capability of the network assets at, or upstream of the point of supply.
- (j) Not interfere with supply quality to other customers or the Distributor's network.
- (k) Not adversely affect the safety of Distributor employees, customers or the public.

A2



- (l) Not be connected on the line side of metering equipment, unless permitted by the Responsible Officer
- (m) Not create a break in the neutral conductor between the Distributor's network neutral conductor and the MEN connection contained within the electrical installation

## **6.9.2 Generator Classification**

Within these rules, generators are classified as either:

### **6.9.2.1 Stand-alone Generator (Normal Supply)**

A generator that is not connected to and cannot connect to the distribution network such as a generator used for remote area power supply or a generator used to provide a temporary electricity supply.

### **6.9.2.2 Standby Generator (Alternative Supply)**

A backup generator used to provide an alternative source of supply when the normal supply from the distribution network is interrupted. All standby generators shall have a break before make transfer (open transition).

### **6.9.2.3 Embedded Generator (Supplementary Supply)**

Any electrical energy source that can connect to the distribution network. This definition includes generators only used for backup that have a make before break transfer (closed transition).

## **6.9.3 Connection and Technical requirements**

### **6.9.3.1 General**

The specifications detailed in these Rules are limited to standby generators, micro embedded generators connected via inverters compliant with AS/NZS 4777 series and UPS systems which are generally considered a standby generator (alternative supply) although may be classified as an embedded generator (supplementary supply) if they are capable of feeding energy into the distribution network.

More detailed information than that provided in these Rules may be obtained from the Distributor's website, by contacting the relevant Distributor as detailed in Section 3, and by submission of an application in accordance with Clause 6.9.3.4 (Notification and Application).

### **6.9.3.2 Stand Alone (Normal Supply)**

Stand-alone generators are not covered under these Rules and for all other forms of embedded generation the connection standards are more complex and specific requirements shall be sought from the relevant Distributor.

### **6.9.3.3 Standby Generator (Alternative Supply)**

### **6.9.3.4 Notification and Application**

A micro embedded generator is a basic connection under the National Energy Rules and includes an embedded generating unit as described in AS/NZS 4777 series.

It is a requirement before the installation of a micro embedded generator or a Battery Energy Storage System (BESS) that application shall be made to the Distributor for their terms and conditions for the connection of a micro embedded generator to the grid. In some cases, a pre-approval process is a requirement by some Distributors, but in all cases a PV connection application shall be submitted. A micro embedded generator or a Battery Energy Storage System (BESS) shall not be connected to the grid unless the distribution business has been notified and has agreed to the connection.

A2

**6.9.3.5****Technical**

- (a) The customer's alternative supply shall be installed in accordance with AS/NZS 3000 and the following requirements:
- (i) Only to provide supply to installations connected to one point of supply; and
  - (ii) Not to be connected as a supply source to the distribution network
- (b) Earthing arrangement shall comply with AS/NZS 3000 and AS/NZS 3010.
- (c) Isolation devices shall comply with AS/NZS 3000 and AS/NZS 3010
- (d) Labelling shall comply with AS/NZS 3000 and AS/NZS 3010

A2

**6.9.3.6****Embedded Generator (Supplementary Supply)****6.9.3.7****Inverter Energy Systems****6.9.3.8****Notification**

In some situations, the distribution network may not support generators above a certain size without modification or upgrade to the network. Each Distributor may assess generators above a certain size. The size over which an assessment is required may vary between Distributors.

If the Inverter Energy System is installed within an Embedded Network an application for approval to the Embedded Network Manager is required prior to installation.

A3

**6.9.3.9****Technical****6.9.3.10****Product**

All inverters shall comply with the requirements of AS/NZS 4777.2 and be listed on the Clean Energy Councils list of approved inverters at the time of installation.

**6.9.3.11****Inverter Protection Settings**

The inverter voltage and frequency protection settings shall comply with the requirements of AS/NZS 4777.2

**6.9.3.12****Installation**

For inverter energy systems (IES) up to or equal to 200 kVA for the injection of electrical power to an electrical installation connected to the grid at low voltage shall comply with the requirements of AS/NZS 4777.1

For inverters energy systems greater than 200 kVA the requirements of AS/NZS 4777.1 should be followed.

**6.9.3.13****Isolation**

Isolation devices shall comply with AS/NZS 3000 and AS/NZS 4777.

**6.9.3.14****Control and Protection**

Requirements for inverter integrated protection and central protection shall apply as per AS/NZS 4777.1 Central protection shall be located at the main switchboard or adjacent to the main switchboard as agreed by the Distributor.

A2

**6.9.4.15****Voltage Rise Requirements**

Voltage rise from the Inverter terminals to the point of supply shall comply with the requirements of AS/NZS 4777.1

The following points shall be considered when calculating the voltage rise:

- (a) Rated output current of IES

A2	(b) New and existing cables (mains, sub mains & etcetera) of the installation
	(c) Cables to be installed in compliance with AS/NZS 3008.1.1
A3	<p><b>6.9.3.16 Labelling</b></p> <p>Labelling shall comply with the Electricity Safety Act 1998 and the Electricity Safety (General) Regulations, AS/NZS 3000 and AS/NZS 4777.1</p>
	<p><b>6.9.3.17 Location</b></p> <p>The location of the inverter shall comply with the requirements of AS/NZS 3000 and AS/NZS 4777.1</p>
	<p><b>6.9.3.18 Specification and Configuration</b></p> <p>All Inverters installed and connected in accordance with AS/NZS 4777 series are deemed to be embedded generators.</p> <p>Unless agreed to by the Distributor, the rating limit for a single-phase Inverter Energy System (IES) in an individual installation shall not be greater than 5 kVA.</p> <p>For multi-phase electrical installations, IES shall have a balanced output with respect to its rating with a tolerance of not greater than 5 kVA unbalance between any phases.</p>
	<p><b>6.9.3.19 Central Voltage and Frequency Protection</b></p>
	<p><b>6.9.3.19.1 General</b></p> <p>Central protection shall be installed to perform the following functions:</p> <ul style="list-style-type: none"> <li>(a) co-ordinate multiple IES installations at the one site</li> <li>(b) provide protection for the entire IES installation</li> <li>(c) provide islanding protection to the connected grid; and,</li> <li>(d) preserve safety of grid personnel and the general public</li> </ul>
A2	<p><b>6.9.3.19.2 Central Voltage and Frequency Protection requirements:</b></p> <ul style="list-style-type: none"> <li>(a) in addition to inverter integrated protection as per AS/NZS 4777.2, additional voltage and frequency protection shall be provided for IES greater than 30 kVA, unless otherwise specified in AS/NZS 4777.1.</li> <li>(b) Central voltage and frequency protection set points shall be in accordance with AS/NZS 4777.1. <ul style="list-style-type: none"> <li><i>Exception; sustained over voltage (<math>V &gt;</math>) (based on average value over a period of 10 min) may operate up to 258V,</i></li> </ul> </li> <li>(c) Central Protection settings shall be secured against inadvertent or unauthorised tampering. Changes to settings shall require the use of a tool and special instructions not provided to unauthorized personnel. <ul style="list-style-type: none"> <li><i>Note; Special interface devices and passwords are deemed as tools for the purpose of this clause</i></li> </ul> </li> <li>(d) Where Phase Balance Protection is required as per AS/NZS 4777.1, it shall respond to current imbalance at the IES connection point caused by an IES between phases greater than 21.7 amps (5 kVA at 230 V) by automatic operation of a disconnection device.</li> </ul>

**6.9.3.19.2.1 Export control**

- (e) Where the Distributor has approved the IES export control kVA value, which is less than the inverter capacity, it shall be secured against inadvertent or unauthorised tampering. Changes to settings shall require the use of a tool and special instructions not provided to unauthorised personnel.

*Note; Special interface devices and passwords are deemed as tools for the purpose of this clause*

- (f) The settings, including hard and soft limits, shall be in accordance with AS/NZS 4777.1

**6.9.4 Battery Energy Storage Systems (BESS) (Alternative or Supplementary Supply)**

Some multi-mode inverter based embedded generation systems may incorporate battery storage as part of the embedded generation system.

The battery storage may be arranged as either an Alternative Supply or a Supplementary Supply

**6.9.4.1 Alternative Supply**

Supplies from battery storage systems in conjunction with multi-mode inverters shall be separated from supplies from the Distributor supply and installed as per the requirements of AS/NZS 3000 and AS/NZS 3010.

**6.9.4.2 Supplementary Supply**

Supplies from battery storage systems in conjunction with multi-mode inverters are permitted to synchronise with the Distributor supply and installed as per the requirements of AS/NZS 3000 and AS/NZS 4777 series.

**6.9.5 Certification and Commissioning**

Upon certification by a licensed electrical inspector the installer shall provide the following to the Distributor:

- (a) A Prescribed Certificate of Electrical Safety (CoES).
- (b) Any Verification Commissioning Reports as required by the Distribution Business
- (c) An Electrical Work Request (EWR) providing an explanation of any service and metering modifications that need to be made by the Distributor including meter upgrade for embedded generation.
- (d) A completed application form for the connection of embedded generation including all required information such as installed capacity and inverter model. The inverter model shall be on the Clean Energy Council's list of approved inverters.

Following the installation of an inverter connected embedded generation system compliant with AS/NZS 4777 commissioning shall be undertaken by the installer. This commissioning shall include all work to prepare documentation and manuals for the owner or operator, to do inspections, to provide training and to do all tests necessary to ensure the system and all of its components operate as required under the relevant regulations.

The installer will normally follow a standard documented commissioning plan which is not contained here but shall include a test to ensure that "islanding" does not occur (unless explicitly allowed by the Distributor). That is, the system shall not continue to provide an a.c. electrical power supply on the distribution network when the main supply from the Distributor's network is de-energised. The Distributor's representative may also undertake independent tests to ensure "islanding" does not occur.

The Distributor provides consent for the installer to synchronise AS/NZS 4777 compliant inverters to the Distributor's network for testing purposes, if permanent supply is available at the installation, prior to final approval or metering upgrade however the following conditions apply:

- (e) The installation shall comply with all standards. The only exemption is that metering upgrades do not need to be complete.
- (f) The duration of the tests shall be kept to an absolute minimum to test protection and controls such as anti-islanding functions. Long run tests such as temperature rise or daily energy production tests, are not permitted until all works and approvals are obtained.
- (g) The tests shall be undertaken under controlled conditions to minimise risk. Precautions shall be taken to ensure no persons are working on or are located within the vicinity of electrical components including the service and metering equipment. Warning labels shall be attached advising that electrical testing is underway.
- (h) This clause does not provide authority to disregard any other act or regulation however it provides a means of testing by using the distribution network without requiring the use of independent generator test sets and load banks which may not be practical.
- (i) If any defect is identified during the tests the generator shall be disconnected as quickly as possible. Upon completion of all tests the a.c. isolating device shall remain in the open position with mechanical locking device to prevent inadvertent switch on until all work is complete, and all approvals obtained.

A2

## **6.9.6 Standby Generation**

### **6.9.6.1 General**

Standby supplies are a separate electricity supply to the electricity supply provided from a Distributor's network into an installation and/or occupancy. These supplies are designed to provide a temporary independent alternative electricity supply for either part or all of an installation or occupancy in the event of a loss of supply from the Distribution network. Standby generators can also be utilised as part of a demand management system or as part of a micro renewable energy system that may operate even though network supply is available.

The standby alternate electricity supply may be from a variety of sources such as a petrol, diesel, bio-fuel, LPG or natural gas generator or from a renewable energy source such as wind turbine or photovoltaic array together with energy storage such as a battery. The standby generator will consist of either a synchronous machine driven by an engine or an inverter that can operate in island mode.

An uninterruptible power supply (UPS) usually utilises a battery or other energy storage device such as a flywheel and requires an inverter but may also be used in conjunction with a generator.

Standby supplies may be permanently installed, re-locatable and/or portable and may be automatic or manual in operation.

### **6.9.6.2 Standby Synchronous Generator**

Under no circumstances is a standby synchronous generator permitted to parallel with the distribution network supply, even for short periods during changeover or for maintenance or testing.

### 6.9.6.3 Break Before Make System

The break before make system is an interlock which breaks the Distributor's network supply downstream of the meters prior to connecting the alternative supply. Control switchgear should be selected and installed in accordance with AS/NZS 3010 and may include:

- (a) Automatic transfer
- (b) Manual transfer
- (c) Temporary generator, manual rewiring

### 6.9.6.4 Uninterruptible Power Supply (UPS) System

For any UPS that can synchronise and parallel with the distribution network the following two conditions apply:

#### 6.9.6.4 (a) Maximum Parallel Time Between UPS Inverter and the Distribution Network

For any UPS design that synchronises and parallels its electrical output with the distribution network the maximum parallel time permitted without requiring Distributor approval is 100 ms. If the UPS parallels with the distribution network for longer than 100 ms the Distributor shall be consulted, and it may be necessary for the UPS to be treated as an embedded generator.

#### 6.9.6.4 (b) Maximum UPS Inverter Output Rating Without Distributor Consultation

If a UPS is designed to synchronise and parallel with the distribution network, then its total combined rating per installation shall be less than 1 MW otherwise consultation with the Distributor is required and it may even be necessary for the UPS to be treated as an embedded generator. A UPS of this size could have a material impact on network short circuit fault levels.

If the UPS can parallel with the distribution network for more than 100 ms or can parallel with the distribution network and is larger than 1 MW then in general, it shall be treated as an embedded generator. The Distributor shall be consulted so that the appropriate standards and or Policies can be obtained.

#### 6.9.6.4.1 Generation With 'Make Before Break' Transfer Switching

In some circumstances it is desirable to be able to transfer load from the distribution network supply to the generator or vice versa without interrupting the supply to the generator. This type of transfer is called a make before break (or closed transition transfer) and requires a generator to be able to synchronise with the distribution network supply. Backup generators with make before break transfer allow the generators to be load tested without disrupting the load. Likewise, they may allow the load to be transferred from the generator back to the distribution network supply when the electricity supply on the network is restored without a further interruption of electricity supply to the load.

Any generator that can synchronise with or electrically connect to the distribution network is considered an embedded generator. Thus, backup generators with make before break transfer are classified as embedded generators even though they may only be used as backup supplies and connect to the distribution network for short periods of time (less than 10 seconds).

Generators with make before break transfer require a connection agreement with the Distributor because they are considered embedded generators. The connection standards

A2

that apply for this class of generator may be relaxed however this will depend upon the connection duration, generator size and other factors. These generators will be designed such that it is not possible for them to export energy to the distribution network thus bi-directional metering will not be required.

The following guidelines apply however this is not an exhaustive list of requirements and further information shall be sought from the Distributor to obtain the appropriate standards before designing a generator with make before break transfer:

- (a) Generator synchronisation and parallel with the distribution network shall use an automatic controller and the design shall include a synchronisation check relay which will only permit paralleling of the generator and distribution network supply if the generator is correctly synchronised.
- (b) Parallel of the generator with the distribution network will be limited to a maximum time and a timer shall be installed to disconnect the generator from the distribution network if this time is exceeded. In general, this time will be set less than the reclose time for the feeder protection on the Distribution network.
- (c) If the maximum parallel timer is set to 1 second or more anti-islanding protection using the principle of 'rate of change of frequency' or 'vector shift' will be required to disconnect the generator when the network supply is interrupted.
- (d) The maximum parallel time shall not exceed the maximum parallel timer setting even if any single component of the generator plant fails (i.e. redundancy or fail-safe design is required to ensure the generator cannot parallel with the distribution network supply for more than the permitted time).
- (e) The generator shall have over current protection, under voltage protection, over voltage protection, under frequency protection and over frequency protection.
- (f) In general, the generator cannot cause the fault levels on the distribution network to exceed the lesser of the Electricity Distribution Code or network plant ratings. The Distributor will provide the maximum fault level contribution from the generator upon request.
- (g) All protection and control designs and settings, commissioning and testing plans, and maintenance policy shall be submitted to the Distributor for review.
- (h) The Distributor may request additional protection. Examples include negative sequence, zero sequence, neutral displacement, reverse power flow, pole slipping etc. This will depend upon the type and size of generator and the potential risks although these additional types of protection are generally only required for embedded generators that parallel with the distribution network for long durations.
- (i) The use of an Automatic Transfer Switch with the mechanical interlock disabled (make before break) operation is permitted as per the requirements of AS/NZS 3010.

A2

### 6.9.7

#### **All Other Forms of Embedded Generation**

A generator that can connect to or synchronise with the distribution network is defined as an embedded generator even if the parallel only occurs occasionally, or only occurs for short periods of time, or even if the generator does not export energy into the distribution network. Examples include small scale photovoltaic systems with inverter connections, combined heat and power (CHP) or tri-generation and backup supply generators that are designed to synchronise for short periods of time during change over from generator to network or vice versa (closed transition).

Embedded generators connected via small scale inverters compliant with AS/NZS 4777.2 can connect to the distribution network via a streamlined connection process. For inverter systems under a certain size, automatic approval to connect to the distribution network

will be granted, if all standards are satisfied and information requested by the Distributor is provided.

For all other types of embedded generation, the applicant shall submit a connection enquiry, followed by a connection application, then negotiate the access standards and finally enter into a connection agreement with the Distributor. The technical access standards for embedded generators in this class are complex and are not fully addressed within these rules. Refer to Section 9 Appendix A4 for further information on HV Embedded Generation requirements

The embedded generator access standards may vary slightly between each Distributor or depend upon the network connection location. These standards can be obtained from each Distributor's website, by contacting the relevant Distributor as detailed in Section 3, or by submission of an application in accordance with Clause 6.9.3.4 (Notification and Application). The connection of embedded generators will require consideration of a range of factors including but not limited to metering, protection and control, fault levels, power quality and network performance standards.

The generator applicant should make contact with the Distributor who will guide the applicant through the generator connection process and provide detailed information and specific support in accordance with the process described in Chapter 5 of the National Electricity Rules (NER)

## **6.9.8 Embedded Generation Metering**

### **6.9.8.1 Bidirectional Metering**

In general, embedded generation metering requires an electronic meter with separate import and export registers (bidirectional metering) that will accept periods of reverse power flow, i.e. when power is flowing into the network from a customer's premises. Bidirectional metering may not be required in special circumstances where reverse power flow is not possible as described below, however this will require the approval of the Distributor.

Where an embedded generator is not capable of exporting energy to the distribution network it may not be necessary to install bi-directional energy metering. All other obligations remain. To ensure the generator cannot export energy to the distribution network it is necessary to either:

- (a) install reverse power flow protection that will trip the generator (or disconnect the whole installation from the distribution network) when energy follows in the reverse direction (from a customer installation into the distribution network), or
- (b) demonstrate that the minimum load within an installation will always exceed the maximum generator output by a significant safety margin.

In both cases, it is necessary to obtain the approval of the Distributor to avoid the need to install bi-directional energy metering.

For a standby generator or an UPS only standard unidirectional metering is required, that is, the generator does not affect the metering installation and the generator can be ignored from a metering perspective. Likewise, installations containing electric motors with regenerative braking will not require bidirectional metering unless it is large and causes reversal of power flow at the network connection.

### **6.9.8.2 Electricity Tariff**

The installation of a grid connected embedded generator may impact on a customer's existing electricity tariff. Negotiation with an electricity Retailer is required to obtain the most suitable tariff.



## 6.10 Un-metered Supplies

### 6.10.1 General

These Rules shall apply to all un-metered supplies connected to the electrical distribution network including those un-metered connections that are to be upgraded or altered after the original connection date.

AMEO have classified un-metered supplies as either:

(a) Type 7 "Predictable Loads"

Which require prior agreement of a device type and load table with AEMO and evidencing via NATA reports. In Victoria, only public lighting is permitted to be a type 7 contestable un-metered load under the National Electricity Rules (NER). or

(b) NONCONUML "Agreed Loads"

All other un-metered loads must be connected as a non-contestable un-metered load (NCONUM) and must buy their energy from the default Retailer of the relevant distribution network area. Within the National Electricity Market (NEM), the load and load profile for an un-metered device is needed to facilitate billing. The customer, Retailer and Distributor must have obtained an agreement of the load and load profile for each device type prior to any request for connection of the device type to the network.

These Rules do not include un-metered supplies that are AEMO approved as type 7 for which a load table exists.

Un-metered supplies consist of a small electrical installation with an energy consumption that can be determined without the need for a billing meter. The load shall be determined as the total connected wattage (or name plate rating) of the un-metered installation at the point of supply.

The Distributor will provide the maximum size in their distribution area for an un-metered supply during the approval process. Generally, loads less than 500 watts (2 amperes single phase) will be considered for an un-metered connection of a load that is predictable and flat in nature.

	<b>AusNet</b>	<b>CitiPower</b>	<b>Jemena</b>	<b>Powercor</b>	<b>United Energy</b>
Maximum total 1Ø load	2 amps	2 amps	2 amps	2 amps	2 amps

Un-metered supplies are typically located in public land or council reserves.

### 6.10.2 Eligibility

#### 6.10.2.1 Eligible

An un-metered connection and supply in a public space is available to eligible customers subject to the conditions and requirements detailed in the Rules and any associated Distributor requirements. Eligible customers are generally statutory and government bodies who can own and operate electrical installations within public spaces.

#### 6.10.2.2 Ineligible

A load subject to customer-controlled variations in usage duration is not permitted as an un-metered supply (i.e. water pumping). No temporary un-metered supplies will be made available (i.e. festival lighting and Christmas lighting), any such supplies shall be metered.

No socket outlets where an appliance can be plugged into shall be permitted as an un-metered supply, or as a part of an un-metered supply, unless the installation is located on

A3

a distribution pole and is not accessible to the public. An un-metered connection must be dedicated to the primary device being supplied.

### 6.10.2.3

#### **Classification**

Un-metered supplies subject to the load requirements typically apply to:

- (a) General classification
  - (i) Parking ticket machines
  - (ii) Surveillance systems
  - (iii) Automated public toilets
  - (iv) Sewerage, drainage, water pressure and pipe alarms
  - (v) Irrigation controllers
  - (vi) Public lighting
- (b) Communication classification
  - (i) Basic public telephone/communication sites
  - (ii) Communication devices. (i.e. Multiplexers, NBN cabinets)
  - (iii) Transmitter and antenna sites, Wi-Fi or 5G
  - (iv) Transport and communication shelter combinations
  - (v) Cable TV systems
- (c) Traffic classification
  - (i) Variable speed signs
  - (ii) Traffic alerts signs
  - (iii) Parking availability space signs
  - (iv) Pedestrian crossings
  - (v) Bus shelters

### 6.10.3

#### **Connection requirements**

#### 6.10.3.1

#### **Connection process**

#### 6.10.3.1.1

#### **Approval**

Approval is required to be obtained for an un-metered supply. The approval process will determine:

- (a) Eligibility for the electrical installation to be classified as an un-metered supply;
- (b) The establishment of a point of supply, normally a distribution pole or a service pit;
- (c) Any costs to establish the point of supply;
- (d) Any conditions for works in public land.

Any installation work should not commence until confirmation has been obtained from the Distributor for the terms and conditions of the un-metered connection.

The following information will be required at the time of the initial approval request:

- (a) Location of the electrical installation on public land or on a distribution pole. Note: electrical installations mounted on a distribution pole require a Facilities Access Agreement with the Distributor.

A3

- (b) Full technical specifications for the proposed equipment and operational/physical arrangements.
- (c) A single line diagram of the electrical arrangement.
- (d) Proposed route plan of any underground consumer mains. Note: clause 5.7 Private Electric Lines on Public Land.

#### **6.10.3.1.2 Connection**

The connection application of an un-metered supply is made by the customer or their agent to the Retailer who will raise a B2B request to the Distributor for connection. The Registered Electrical Contractor via the Distributor's connection process will need to provide the following information at the time of the connection request:

- (a) Certificate of Electrical Safety COES
- (b) As built plans for any underground consumer mains in public land
- (c) A completed Facility Access Agreement if approved to mount any equipment on a distribution pole

Once submitted the connection will be assessed and scheduled for completion upon the Distributor receiving the Retailer B2B connection request.

#### **6.10.3.2 Facility Access Agreement**

Before any third-party equipment is placed on or within a distribution asset, a Facility Access Agreement (FAA) must first be in place which addresses technical, safety, indemnity, insurance, liability and other commercial requirements associated with the equipment.

The applicant shall install and manage their attachments according to Distributor safety and technical requirements which reflect the Victorian Electricity Safety Act, regulatory obligations and Distributor standards and codes.

Distribution assets include distribution poles, public lighting poles, underground conduits and cableways, substation buildings, associated real estate within distribution owned facilities and communications fibre huts.

#### **6.10.4 Technical requirements**

##### **6.10.4.1 Electrical installation**

###### **6.10.4.1.1 General**

The customer must ensure that the customer's installation is wired by a licensed electrical installation worker in accordance with the requirements of the Electricity Safety Act, Electricity Safety (General) Regulations including the Wiring Rules AS/NZS 3000

A consumer's switchboard, main earth electrode and MEN connection shall be established prior to, or at the consumer's equipment/device unless the un-metered electrical installation is double insulated throughout. The consumer's un-metered supply and installation shall be earthed in accordance with the requirements of AS/NZS 3000.

###### **6.10.4.1.2 Compliance**

The installation shall comply will all applicable Acts, Regulations, Codes and Standards. Failure to meet these requirements will delay the connection of supply. If at any time the installation is found to be non-compliant with any Acts, Regulations, Codes and Standards, it will be subject to disconnection without notice and a defect notice will be issued.

A3

Mandatorily clearances between un-metered equipment and distribution assets are specified in the Shared Use of Poles Code that apply to all new Shared Use attachments on distribution poles

### 6.10.4.1.3 Maintenance

Where the customer's electrical installation is mounted on a distribution asset, the un-metered supply arrangement shall be routinely checked and tested by the party responsible for the installation. Testing and checking is to ensure the installation is safe to remain on supply and presents no risk to the safety of the public or electrical workers. Routine checks shall be performed no less than at a minimum once every five years and evidence provided to the Distributor upon request that the installation is in good condition and safe to leave on supply.

As a function of the routine maintenance checks, a record of inspection activities undertaken at the site demonstrating that the installation has been tested and is safe to remain connected to the network is required. Record of inspections shall be retained by the customer and made available to the Distributor upon request. All other requirements of section 8 of AS/NZS 3000 shall be met together with the requirements of AS/NZS 3019.

#### 6.10.4.1.3.1 Tests

Tests are to be performed at routine maintenance checks in accordance with AS/NZS 3000 section 8 and shall include, but are not limited to:

- (a) Continuity of the earthing system in accordance with AS/NZS 3000
- (b) Insulation resistance of wiring and equipment in accordance with AS/NZS 3000
- (c) Polarity in accordance with AS/NZS 3000

If any of the above tests do not satisfy the requirements of AS/NZS 3000, the installation shall be disconnected from supply immediately and notification to the Distributor provided within 1 working day.

#### 6.10.4.1.3.2 Frequency

Testing and checking of the installation shall be performed at a minimum once every five years

#### 6.10.4.1.3.3 Reporting

Testing and checking reports and evidence shall be provided to the Distributor upon request.

#### 6.10.4.1.4 Alteration to installation

Any proposed changes to the configuration of the un-metered installation shall be requested by the customer to the Distributor and Retailer.

Scenarios to notify the Distributor and Retailer:

- (a) Alterations to customer equipment on Distributor poles that may impact the FAA.
- (b) Change to equipment in public land – requires new as built drawings and/or ESV exemption.
- (c) Increase or reduction in proposed consumption – network billing changes.
- (d) Increase in energy consumption that requires change to a metered supply.

#### 6.10.4.1.4.1 Configuration

Changes to the electrical installation including equipment mounted on distribution poles shall not be undertaken unless approval has first been granted by the Distributor.

A3

**6.10.4.1.4.2 Load**

No change to the supply demand shall be made unless it is still within the rating of the 2 amp supply capacity device and has been approved by the Distributor.

Legacy un-metered connections outside of the 2 amp requirement shall be converted to metered supply if being upgraded or modified.

**6.10.4.1.5 Removal of connection**

Until such time as the un-metered supply is removed or the customer advises in writing that the un-metered supply is no longer required, the customer shall continue to pay all connection, supply and usage charges.

To arrange disconnection and removal of an un-metered supply, the applicant shall complete a request via the Retailer and Distributor's processes for the abolishment of the connection.

**6.10.4.2 Distributor – Technical requirements****6.10.4.2.1 Point of Supply**

In accordance with Clause 6.2 as a condition of supply the Distributor is responsible to determine the point of supply.

The point of supply is the point at which the electricity Distributors service cable or supply main connects to the consumer's terminals.

The determination of the point of supply will include the location, the supply capacity and electricity supply configuration.

For an un-metered supply, the point of supply will generally be on a distribution pole or in a distribution service pit. In some cases, an overhead service to a gantry may be an option.

Distribution poles that include high voltage distribution devices such as transformers, switches and high voltage underground cable terminations are not suitable for a customer point of supply.

**6.10.4.2.1.1 Pole**

The distribution system includes different pole types of, wood, composite, metal and concrete. These vary in mechanical loading strengths and supply configurations such as attached overhead low voltage reticulation to the pole or supplied internally from underground reticulation.

The point of supply at a pole is nominated by the Distributor and is normally 4 metres from ground level. The customer shall be responsible for the installation of their consumer's mains cables and equipment to a height of 4 metres above ground level. The relevant Distributor shall be responsible to perform any works above 4 metres as per clause 7.5.4.2.

**6.10.4.2.1.2 Underground**

The point of supply is the service pit, located in the public land.

The provision of a point of supply from an existing service pit shall consider the existing and future connections when located on property boundaries. A point of supply shall not be provided if the maximum number of three connections would be exceeded within the pit.

A point of supply from a service pit will only be provided on the same side of the street as the customer's MSB for the installation.

A3

**6.10.4.2.2 Private electric cable routes**

Un-metered consumer mains in public land shall:

- (a) Not exceed 25 metres route length without approval from the relevant Distributor from the point of supply to the electrical installation unless the customer is an exempt entity under section 47 of the Electricity Safety Act.
- (b) Where cables are extended longitudinally along a road reserve the consumer mains shall be installed parallel with the adjacent title boundary.
- (c) The cable route from the point of supply to the customer installation in a road reserve shall avoid deviations. In general, the cable route shall be installed in a manner that has a maximum of one 90° horizontal bend.

**6.10.4.2.3 Attachments**

The use of a Distributor's pole for the installation of consumer's mains and its associated service protection device, consumer's terminals and the electrical installation shall be in accordance with the Rules.

**6.10.4.2.3.1 Pole**

Equipment other than consumer's mains shall be installed in accordance with the Code of Practice for Shared Use of Poles and the agreement with the relevant Distributor made under clause 7.8 (Equipment other than Consumer's Mains on a Distributor's Pole).

Due to operational and safety concerns the Shared Use of Poles Code 2020 lists the following types of poles as unsuitable for Shared Use:

- Hinged public lighting poles;
- All types of frangible public lighting poles;
- 66kV cable head poles (cable termination poles);
- New attachments to unserviceable poles (this may include use of temporary stays).

Early in the scoping stage confirmation should be obtained from the relevant Distributor for suitability of a pole for attachment of un-metered equipment.

Unless otherwise agreed with the relevant Distributor all electrical installation equipment shall be located such that the equipment:

- (a) Is least liable to mechanical damage;
- (b) Is on the side of the pole least affected by vehicular traffic;
- (c) Does not obscure a Distributor's pole identification disk, mark or number;
- (d) Maintains integrity and be appropriately spaced from network earthing conductors;
- (e) Does not interfere with safe access to other equipment located upon the pole;
- (f) Unless otherwise agreed with the relevant Distributor consumer's terminals installed on poles shall be located at 4 metres above ground level.

**6.10.4.2.3.2 Concrete and Steel (conductive)**

Where consumer's mains and equipment are installed on a conductive pole carrying high voltage conductors, segregation of earthing systems shall generally be required between the pole and the customer's equipment.

Concrete and steel poles shall not be drilled under any circumstances as ingress of moisture can lead to failure of the pole.

Fixing of cables and equipment to non-timber poles shall be achieved by banding with suitable stainless-steel bands and be so arranged that the band will not directly compress on cable sheaths but will securely attach cables and equipment to the pole.

A3

**6.10.4.2.4 Safety**

In addition to clause 5.1 (safety), work on a pole near live distribution assets has obligations for:

**(a) Persons, Mobile Plant or Vehicles**

It is the responsibility of the un-metered asset owner and their workers to comply with all relevant legislation including *The Blue Book* (The Code of Practice on Electrical Safety for Work On or Near High Voltage Electrical Apparatus – [www.esv.vic.gov.au](http://www.esv.vic.gov.au)) for works involving Distribution assets where such works involve persons, mobile plant or vehicles. Further information can be found in the Shared use of Poles Code.

**(b) Worker clearances to live assets**

Workers who need to work on their un-metered equipment, are required to maintain the minimum working clearance as per VESI Safety & Compliance Training Requirements for Telecommunications Work on Victorian Electricity Supply Industry (VESI) Network Operator Assets.

All telecommunications workers shall:

- be aware of and ensure that their minimum training requirements are current;
- undertake any training and assessment as required.

**6.10.4.2.5 Protection & Maximum Demand Limitation**

The electrical installation must be provided with a main control and overcurrent protection via a supply protection device such as a circuit breaker or residual current devices. Load shall be limited to 2 amps as per the conditions for the Distributor's un-metered supply connection and compliance with clause 6.7.2.2, note the 2 metres height limitation requirement does not apply when the SPD is located on a distribution pole.

A3

**6.10.4.2.6 Labelling**

Where a point of supply is provided on a distribution pole and the electrical installation is remote from the pole location, suitable labelling shall be provided to indicate the electrical installation location. Contact details, including the customers business name, should be provided for the controlling authority of the electrical installation. Labelling shall comply with clause 5.4.

**6.10.4.2.7 Earthing**

Where the electrical installation is mounted on the distribution pole and is not double insulated the earth electrode shall be located a minimum of 2 metre distance from the outside face of the pole.

**6.10.4.2.8 Multiple connections**

Multiple points of supply and electrical installations on a distribution pole should be avoided.

**6.10.5 Supplies in public land****6.10.5.1 ESV - exemption**

As per clause 5.7.5 private electrical cables in public land will require an exemption from Energy Safe Victoria. Once approval for an un-metered connection is granted, the Distributor will provide the applicant with written approval for the installation of electrical cables in public land. This approval letter is required to be included as part of customer application to the ESV for the exemption request.

Entities that do not need to seek an exemption from ESV are Local Councils, Vic Roads, Melbourne City Link, Vic Track. Notably, telecommunications companies and water authorities are not exempt.

A3

### **6.10.5.2**

#### **Route plans**

Route plans of as built details for private electrical cables must be submitted to the Distributor prior to or at the time of final connection request. Plans shall be detailed in accordance with Electricity (General) Regulations, Clause 219 Route of underground lines. Sample templates are available from each Distributor.



# Section 7

## Connecting to the Low Voltage (LV) Network

<b>Section 7 - Contents</b>		<b>Page</b>
<b>7.1</b>	<b>Distributor's LV Network/Electrical Installation Connection</b>	<b>7-6</b>
7.1.1	General	7-6
7.1.2	Type of Supply	7-6
7.1.2.1	Network - Underground	7-6
7.1.2.2	Network - Overhead	7-6
7.1.2.3	Sub-stations	7-6
7.1.2.4	Switchboard Locations	7-6
Figure 7.1-A	Typical Switchboard Locations	7-7
Figure 7.1-B	Typical Switchboard Locations	7-7
Figure 7.1-C	Typical Switchboard Locations	7-8
7.1.3	Selection of Connection Type	7-8
<b>7.2</b>	<b>Service Pits</b>	<b>7-8</b>
7.2.1	Provision	7-8
7.2.2	Location	7-9
7.2.3	Terminations	7-9
Figure 7.2-A	Typical Service Pit Locations	7-9
7.2.4	Supply Protection	7-10
Table 7.2-1	SPD – Supply from a Service Pit	7-10
<b>7.3</b>	<b>Underground Service Cables</b>	<b>7-10</b>
7.3.1	Provision	7-10
7.3.2	Connection Facility	7-11
7.3.2.1	General	7-11
7.3.2.2	Location	7-11
Figure 7.3-A	Typical Service Connection Facility Locations	7-11
7.3.2.3	Service Cable Installation	7-12
7.3.2.4	Consumer's Terminals	7-12
Table 7.3-1	Service Cables – Service Connection Facility Requirements	7-12
Figure 7.3-B	UG Service Cables – Supply Connection Facility Requirements	7-13
7.3.2.5	Supply Protection Underground Service Cable Connected to an Underground or Overhead Distribution (No Pit)	7-13
Figure 7.3-C	Typical FSD Termination Method	7-14
Figure 7.3-D	Underground Network Conduit Installation Method	7-15
Table 7.3 -2	SPD – Supply from an Underground Service Cable Connected to an Underground or Overhead Distribution (No Pit)	7-16
<b>7.4</b>	<b>Overhead Services</b>	<b>7-16</b>
7.4.1	Provision	7-16
7.4.2	Cables	7-17
7.4.3	Consumer's Terminals	7-17

<b>Section 7 - Contents</b>		<b>Page</b>
	7.4.4 Aerial Services	7-17
	7.4.4.1 Application	7-17
	7.4.4.2 Aerial Service Types	7-17
	7.4.4.2.1 Standard Service	7-17
	7.4.4.2.2 Mid-Span Service	7-17
	7.4.4.3 Selection	7-18
	7.4.4.4 Point of Attachment (POA)	7-18
	7.4.4.4.1 General	7-18
	7.4.4.4.2 POA Access	7-18
	Figure 7.4-A Minimum Portable Extension Ladder Access Facilities	7-19
	7.4.4.4.3 POA Location	7-19
	7.4.4.4.4 POA, Consumers Terminals and SPD's on Buildings	7-19
A3	7.4.4.4.4(a) Under Veranda Distribution	7-20
	Figure 7.4-B Buildings – POA, Consumer's Terminals & SPD Location	7-21
	7.4.4.4.5 POA on Private Poles	7-22
	Figure 7.4-C Private Poles – POA Consumer's Terminals and SPD Locations	7-22
	7.4.4.5 Service Brackets	7-23
	7.4.4.5.1 General	7-23
	7.4.4.5.2 Provision	7-23
	7.4.4.5.3 Specification, Acceptance and Installation	7-23
	Table 7.4-1 Service Raiser Bracket Acceptance Documentation	7-25
A3	7.4.4.5.4 One Off Brackets	7-25
	Figure 7.4-D Standard Service Bracket Fixing	7-26
	7.4.4.6 Aerial Service Line Clearances	7-26
	7.4.4.6.1 General	7-26
	7.4.4.6.2 Customer's Obligations	7-26
	Figure 7.4-E Common Minimum Service Cable Clearances	7-27
	7.4.4.7 Service Cable Sag	7-27
	Table 7.4-2 Service Cable Sag	7-28
	Figure 7.4-F Service Cable Sag	7-28
	7.4.4.8 Service Cable Routes	7-29
	7.4.4.8.1 Existing Installations	7-29
	7.4.4.8.2 New Installations	7-29
	7.4-G Service Cable Routes	7-30
	7.4.4.9 Supply Protection Aerial Service Cable	7-31
	Table 7.4-3 SPD – Supply from an Aerial Service Cable	7-31
	<b>7.5 Un-metered Consumer's Mains &amp; Sub Mains</b>	<b>7-31</b>
	7.5.1 Cables & Conductors	7-31
	7.5.1.1 General	7-31

**Section 7 - Contents****Page**

	7.5.1.2	Conductor Types	7-31
	7.5.1.3	Conductor Sizes	7-32
	7.5.1.4	Colours & Double Insulation	7-32
	7.5.1.4.1	General	7-32
	7.5.1.4.2	Colour Codes & Sleeving	7-32
	7.5.1.4.3	SDI Cables (Single Double Insulated)	7-32
	7.5.1.4.4	Single Insulated Cables with Reinforced Insulation (with or without a sheath)	7-32
	7.5.1.4.5	Sheathed Multi-core Cables (eg: Orange Circular)	7-33
	7.5.1.4.6	Single Insulated Conductors	7-33
	7.5.1.5	Joints in Un-metered Cables & Conductors	7-33
	Table 7.5-1	Joints in Un-metered Cables & Conductors	7-33
	7.5.2	Underground Mains & Sub-Mains	7-33
	7.5.2.1	Insulation Resistance of Underground Consumer's Mains	7-33
A3	Table 7.5.2.1-A	Minimum Insulation Resistance of Underground Consumer's Mains	7-34
	7.5.2.2	Wiring Systems	7-34
	7.5.2.3	Backfilling	7-35
	7.5.2.4	Termination within a Service Pit	7-35
	7.5.2.5	PVC Service Pits	7-35
	Figure 7.5-A	Requirements for Consumer's Mains Supplied from a Service Pit	7-36
	Figure 7.5-B	Consumer's Mains Termination – Service Pit	7-37
	7.5.3	Termination at Indoor, Kiosk and Ground Type Sub- Stations	7-38
	Figure 7.5-C	Typical Consumer's Mains Termination to Distributors Sub-Stations	7-38
	7.5.3.1	Supply Protection, Indoor, Kiosk or Ground Type Sub- Stations	7-39
	Table 7.5-2	SPD – Supply from an Indoor, Kiosk, Ground or Pole Type Substation located within the property it supplies	7-39
	7.5.4	Termination at a Distributors Pole	7-39
	7.5.4.1	Works Practices	7-39
	7.5.4.2	Responsibilities	7-39
	7.5.4.3	Installation	7-40
	7.5.4.4	Concrete Pole Attachments	7-40
	7.5.4.5	Underground Mains (& Cables & Equipment) Termination	7-40
	Figure 7.5-D	Typical Underground Consumer's Mains Termination on a Distributor's Pole	7-41
	7.5.4.6	Private Aerial Line Termination	7-41
A3	Figure 7.5-E	Typical PAL Arrangements	7-42
	Figure 7.5-F	Examples of Typical Private Aerial Lines & Underground Lines with Private and Transition Poles	7-43

A3 |

<b>Section 7 - Contents</b>		<b>Page</b>
<b>7.6</b>	<b>Builder's Supply in a Permanent Position</b>	<b>7-43</b>
Figure 7.6-A	Typical Arrangements	7-44
<b>7.7</b>	<b>Builder's Supply Pole in a Non-Permanent Position</b>	<b>7-44</b>
7.7.1	Provision	7-44
7.7.2	Supply Poles	7-44
<b>7.8</b>	<b>Equipment other than Consumer's Mains on a Distributor's Pole</b>	<b>7-45</b>
Figure 7.8-A	Maximum Equipment on a Distributor's Pole Without an Agreement	7-46
<b>7.9</b>	<b>Electrical Installations on Public Land</b>	<b>7-46</b>
7.9.1	General	7-46
7.9.2	Labelling	7-46
7.9.3	Meter Locations	7-46
<b>7.10</b>	<b>Multiple Occupancy Buildings and Subdivisions (Supply Arrangements)</b>	<b>7-46</b>
7.10.1	General	7-46
7.10.2	Plan	7-47
7.10.3	Subdivisions Incorporating Common Property	7-47
7.10.4	Subdivisions Not Incorporating Common Property	7-47
7.10.5	Multiple Occupancy Buildings	7-48
7.10.6	Possible Subdivision of Buildings or Land	7-48
7.10.7	Supply Arrangement Diagrams	7-48
7.10.8	Labelling	7-48
7.10.9	Un-metered Connections & Equipment	7-49
7.10.10	Wiring Arrangements	7-49
Figure 7.10-A	Example Supply Arrangements for a Subdivision Not Incorporating Common Property.	7-50
Figure 7.10-B	Example Supply Arrangements for a Subdivision Not Incorporating Common Property.	7-51
Figure 7.10-C	Example Supply Arrangements for a Subdivision Not Incorporating Common Property.	7-52
Figure 7.10-D	Example Supply Arrangements for a Subdivision Incorporating Common Property.	7-53
Figure 7.10-E	Example Supply Arrangements for a Subdivision Incorporating Common Property.	7-54
Figure 7.10-F	Example Supply Arrangements for a Subdivision Incorporating Common Property	7-55
Figure 7.10-G	Example Supply Arrangements for a Subdivision Incorporating Common Property	7-56
Figure 7.10-H	Example Supply Arrangements for a Subdivision Incorporating Common Property	7-57
Figure 7.10-I	Example Supply Arrangements for a Subdivision Incorporating Common Property	7-58

## **7.1 Distributor's LV Network/Electrical Installation Connection**

### **7.1.1 General**

The types of connection and the various requirements for electrical installations to be connected to the LV network are detailed in the following clauses.

The customer shall provide facilities for the connection to the network in accordance with these Rules, at their expense.

Connection equipment supplied and installed by the Distributor shall remain the property of and be maintained by the Distributor.

### **7.1.2 Type of Supply**

#### **7.1.2.1 Network - Underground**

In an area where the network is underground a service pit or underground service line will normally be provided.

#### **7.1.2.2 Network - Overhead**

In an area where the network is overhead, an aerial service cable will normally be installed from Distribution Company assets located within a public road reserve. A service pit or underground service line may also be available or required within an area where the network is overhead.

#### **7.1.2.3 Sub-stations**

Where a service pit, underground service cable or overhead service cable is not suitable, the customer may negotiate the installation of and connection to a Distributors sub-station.

Sub-stations may be of a Kiosk, Ground, Indoor or Pole type dependent on the supply and use situation.

#### **7.1.2.4 Switchboard Locations**

The uninsulated portion of an installation easement system shall not be located within 2000mm of the substation earthing. Refer to the Distributor to confirm the Substation earthing location, Non CMEN or CMEN status, the Substation easement and the preferred switchboard location.

For typical switchboard locations, where located in proximity to a Substation, refer to Fig 7.1-A, 7.1-B and 7.1-C.

A3

A3

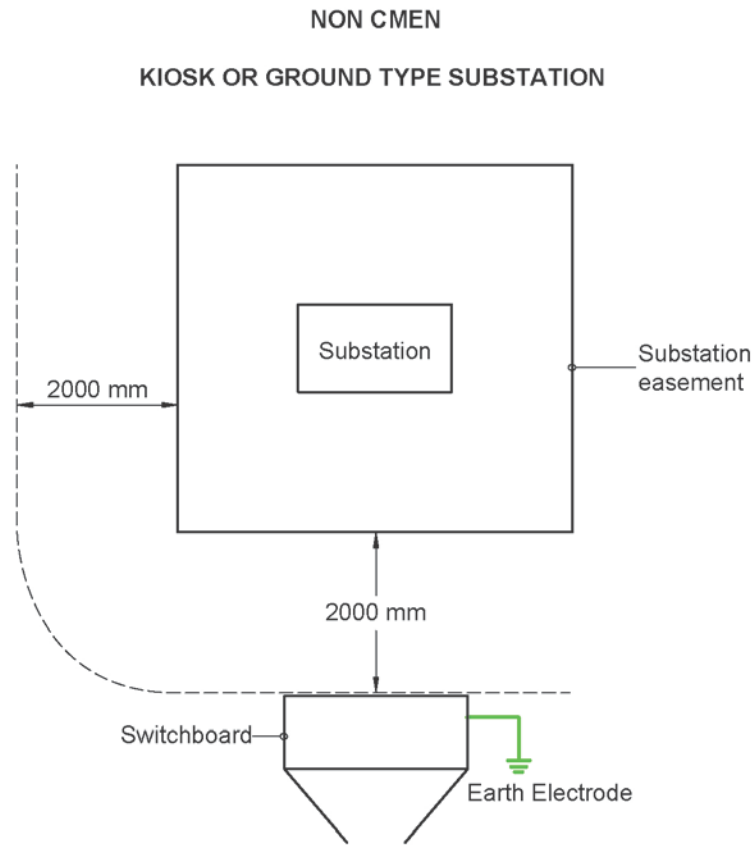

**Figure 7.1-A Typical Switchboard Locations**

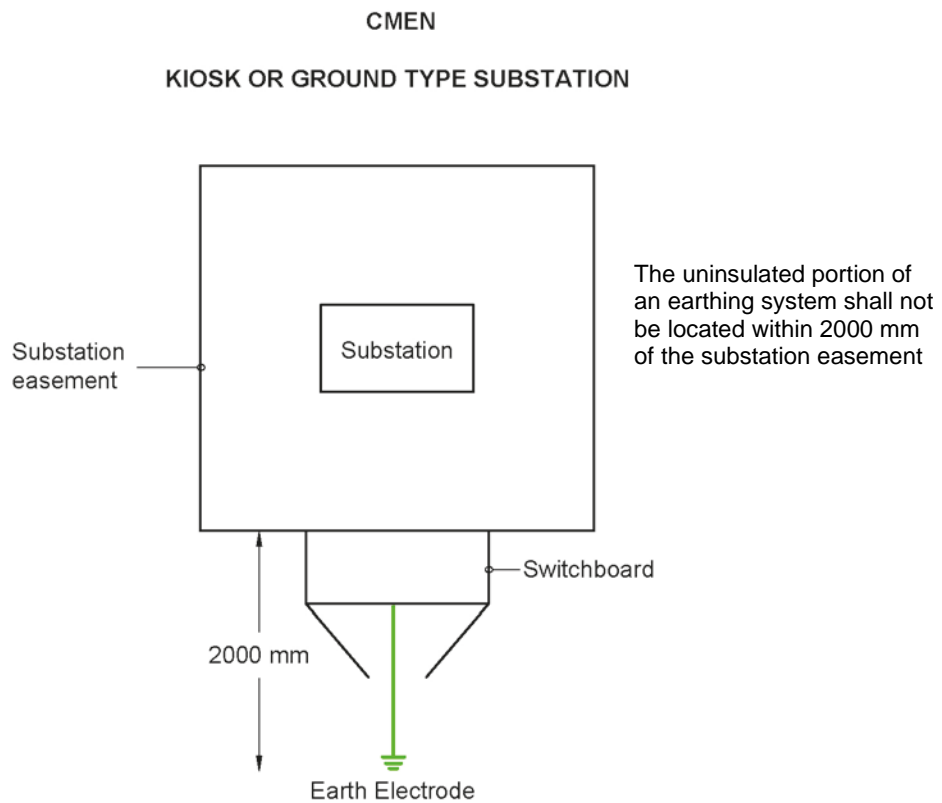

**Figure 7.1-B Typical Switchboard Locations**

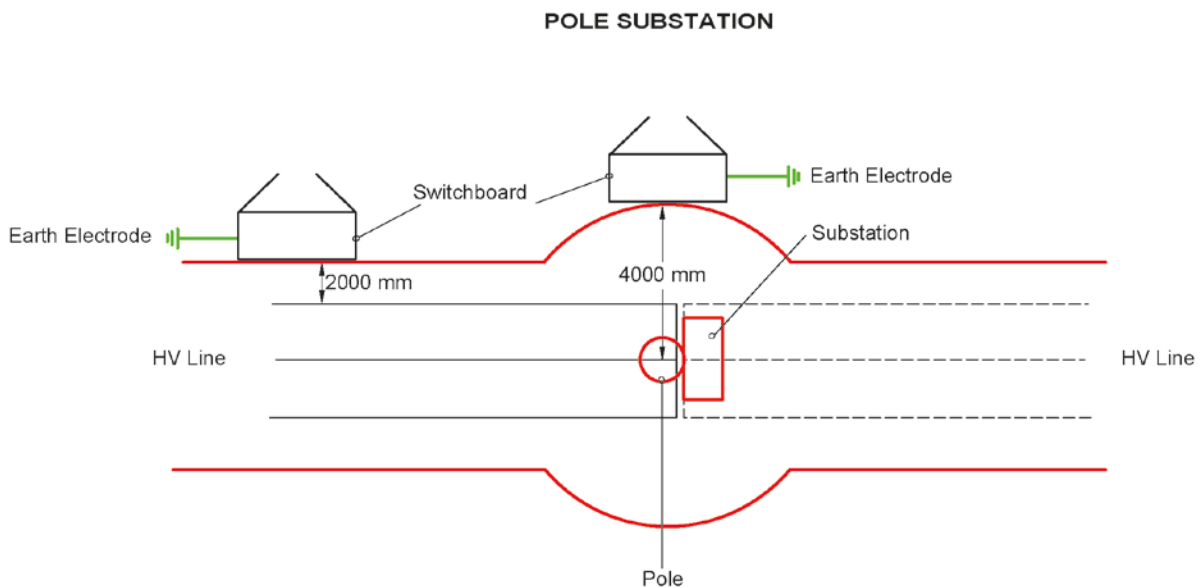

**Figure 7.1-C Typical Switchboard Locations**

### 7.1.3 Selection of Connection Type

The type of connection shall be selected and nominated by the relevant Distributor:

- With consideration to the type of network reticulation to which the connection is to be made, and the supply capacity required;
- In conjunction with clause 6.2 (Point of Supply), where the relevant Distributor nominates the point of supply and consumer's terminals location; and
- In accordance with the Electricity Safety Act and Regulations and the bushfire risk classification of the area as determined by the Fire Control Authority in which the service cable is located; and
- To avoid potential for rectification work, electrical installation work, for the connection to the network should not commence prior to confirming the connection and supply arrangements for the electrical installation with the relevant Distributor.

Note, The Electrical Safety Act 1998, CFA assigns "low" and "high" fire hazard ratings for powerlines to parcels of land in the country area of Victoria and to portions of the metropolitan fire district. For further information refer to the CFA website.

## 7.2 Service Pits

### 7.2.1 Provision

A service pit may be provided where:

- The Electricity Safety Act and Regulations require the consumer's mains to be placed underground in hazardous bushfire risk areas; or
- The connection is to be made in an underground network area, or a customer in an overhead network area is required to have or has requested an underground service pit and the relevant Distributor has agreed; or
- The conditions under which supply is to be provided specify a service pit; and
- The relevant Distributor has agreed for up to 100 Amps per phase to be connected to a shared pit.
  - The Distributor may allow up to 170 Amps per phase to be connected to a dedicated (sole use) pit.



## 7.2.2

### Location

A service pit will normally be located:

- Adjacent to dividing boundaries for provision of supply to adjacent properties, ie, a shared pit; or
- Adjacent to the boundary of a single property, ie, a dedicated (sole use) service pit; or
- At the point of supply adjacent to or within public land or adjacent to a private property boundary.

A standard service pit is not suitable to be located where it may be subjected to vehicular traffic. This may include relocation of the pit if property modifications result in the pit being subject to vehicular traffic.

## 7.2.3

### Terminations

The relevant Distributor will supply, install and connect Insulation Piercing Connectors (IPC's) to the consumer's mains and service cable within a service pit. IPC's accommodate  $\geq 6 \text{ mm}^2$  to  $\leq 50 \text{ mm}^2$  conductors and are regarded as the consumer's terminals for a supply from a service pit.

Refer to Clause 7.5.1 (Cables & Conductors), Clause 7.5.2 (Underground Mains & Sub-Mains), Clause 7.5.2.4 (Termination within a Service Pit) and Figure 7.5-A (Consumer's Mains Termination – Service Pit) for consumer's mains termination requirements.

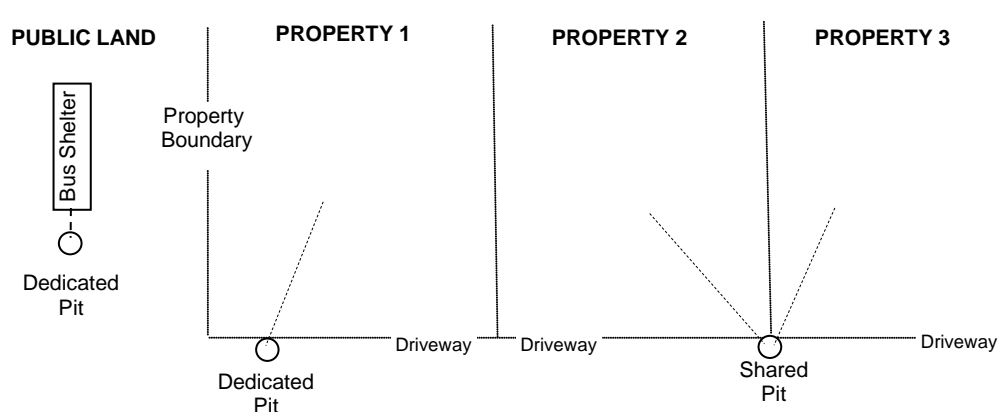

**Figure 7.2-A Typical Service Pit Locations**

## 7.2.4 Supply Protection

Unless otherwise agreed with or required by the relevant Distributor, where supply is provided from a Service Pit the SPD shall be of a type and located in accordance with Table 7.2-1.

**Table 7.2-1 SPD – Supply from a Service Pit Connected to Underground or Overhead Distribution** **FAQ 009**

Supply Current Rating Per Phase	Distribution Reticulation	Supply Protection Assemblies	Responsibility for the provision of Supply Protection Assembly	Supply Protection Device Types Provided by the Distributor	SPD Location
A1 ≤ 100 A	NETWORK U/G from O/H	Panel Mounted Fuse/s	Customer	Type 2a Number of devices shall not exceed one device per phase	Meter Panel
	O/H Reticulation conversion to Underground Reticulation or U/G from O/H	FOLCB	Customer	Type 2a	A point where an overhead line was previously connected*
A1 A3 > 100 A ≤ 170 A Special Circumstances & By Agreement Only	NETWORK U/G	FSD	Customer	Sizes 00, 2 and 3 Din type NH fuses	1. As close as practicable to the applicable property boundary; or, 2. at or within 3 m of the consumer's terminals; or, 3. in a position at or next to the Distributors metering equipment.
	O/H Areas				
	O/H Areas Note: (Dedicated service only)		Customer		1. As close as practicable to the applicable property boundary; or, 2. at or within 3 m of the consumer's terminals; or, 3. in a position at or next to the Distributors metering equipment.
	O/H Reticulation conversion to Underground Reticulation or U/G from O/H		Customer		A point where an overhead line was previously connected*

\* Footnote: Customer shall arrange attachment of a label at the consumer's terminals and main switchboard alerting persons supply is underground.

## 7.3 Underground Service Cables

### 7.3.1 Provision

An underground service cable may be provided where loads exceed the capacity that can be provided from a service pit and/or a service pit is not suitable in the circumstance and where:

- The Electricity Safety Act and Regulations require the consumer's mains to be placed underground in hazardous bushfire risk areas; or

- The connection is to be made in an underground reticulated area, or a customer in an overhead reticulated area is required to have or has requested an underground service cable and the relevant Distributor has agreed; or
- The conditions under which supply is to be provided specify an underground service cable; or
- The relevant Distributor has agreed to install an underground service cable and the load to be connected to it and the customer has a written supply agreement for the connected load; and
- The customer has provided connection facilities in accordance with these Rules.

**7.3.2 Connection Facility**

**7.3.2.1 General**

The customer shall provide a suitable connection facility for the installation and termination of the underground service cable and connection to the consumer’s mains in accordance with these Rules and within a timeframe agreed between the Customer’s Agent and the Distributor.

The connection facility shall be constructed and installed in accordance with the Wiring Rules and these rules in a manner to provide protection from condensation, weather, vandals, vehicles and any other damage that can be reasonably expected.

Un-metered terminals shall be segregated from other equipment, and removable covers to provide access to un-metered terminals shall be provided with sealing facilities and/or a Distributor’s lock in accordance with Clause 5.6. (Sealing & Locking - General).

**7.3.2.2 Location**

The connection facility shall be located and maintained in a readily accessible position that:

- Is agreed with the relevant Distributor; and
- unless otherwise agreed with the Responsible Officer has a 1m clear access space in front of each face of access needed (refer Table 7.3-1) to install and connect the service cables and to enable maintenance and operation of any equipment.
- Is abutting or adjacent or is as close to the property boundary as practicable; or
- Minimises the distance of service cable within the property to  $\leq 3m$ ; and
- any change of direction shall be agreed with the Distributor;

A3 |

A3 |

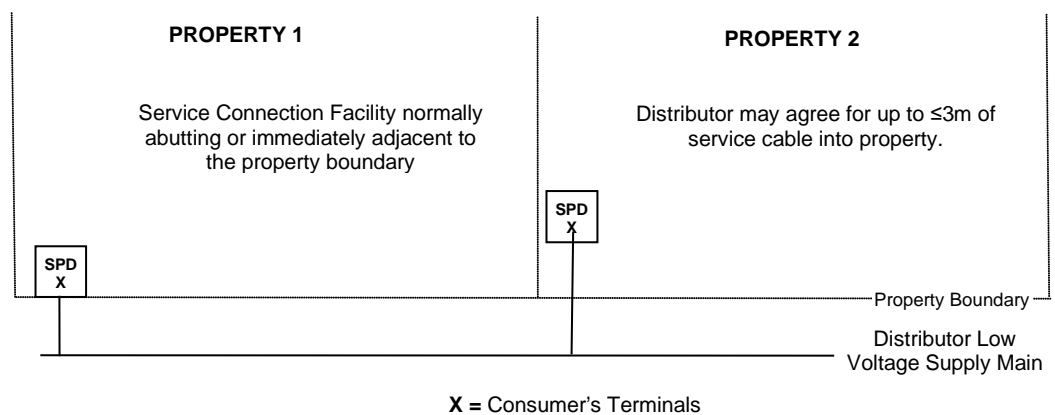

**Figure 7.3-A Typical Service Connection Facility Locations**

### 7.3.2.3 Service Cable Installation

Conduits and cables shall be installed in accordance with Table 7.3-1 and Figures 7.3-B, 7.3-C & 7.3-D.

Dependent upon the supply agreement, the installation of the conduit and/or cables may be partially or completely installed by the customer or Distributor.

The customer shall liaise with the Distributor regarding the service conduit and cable installation to ensure it is installed in a timely and correct manner which co-ordinates with their construction program.

### 7.3.2.4 Consumer's Terminals

**FAQ 013**

The consumer's terminals for an underground service cable shall be:

- A fixed M12 stud unless otherwise agreed with the relevant Distributor;
- Fixed within the service connection facility in accordance with the clearances detailed in Table 7.3-1 and Figure 7.3-B;
- Arranged so as paralleled service cable terminations with a demand of  $\geq 170$  Amp about one another on a stud or are fixed on a separate stud;
- Adjacent to the service protection device where located within a service connection facility;
- Compatible to the Distributor's service cable termination; and
- Maintained by the customer in a condition that allows the Distributor's service cable to be safely accessed, disconnected and reconnected.
- Where a door or escutcheon is provided to a Supply Connection Facility to access the consumers terminals, it shall be hinged on a vertical side and capable of being secured in the open position at a minimum of  $90^\circ$  to the closed position

**Table 7.3-1 Service Cables – Service Connection Facility Requirements** **FAQ 008**

SERVICE CABLE		SERVICE CONNECTION FACILITY		
Service Cable Size	Minimum Conduit size for Service cable (mm)	Minimum clear space between bottom of the door opening and consumer's terminals		Minimum horizontal distance between centres of consumer's terminals & openings
		One or two faces of access (eg, CT enclosure with 1 door access)	Three or four faces of access (eg, pillar with lift off cover)	
		Dimension A (mm)		
1 X $\leq 35$ mm <sup>2</sup> Cu XLPE	63	260	260	75
1 X 50 mm <sup>2</sup> Cu XLPE	80	260	260	75
1 X 185 mm <sup>2</sup> Alum.	100*	500	360	100
1 X 240 mm <sup>2</sup> Alum.	100*	500	360	100
2 X 50 mm <sup>2</sup> Cu XLPE	100	450	260	75
2 X 185 mm <sup>2</sup> Alum.	2 x 100*	700	600	100
2 X 240 mm <sup>2</sup> Alum.	2 x 100*	700	600	100

\*Sizes are for maximum 4m route length and one bend. Refer to Distributor for other situations.

A3

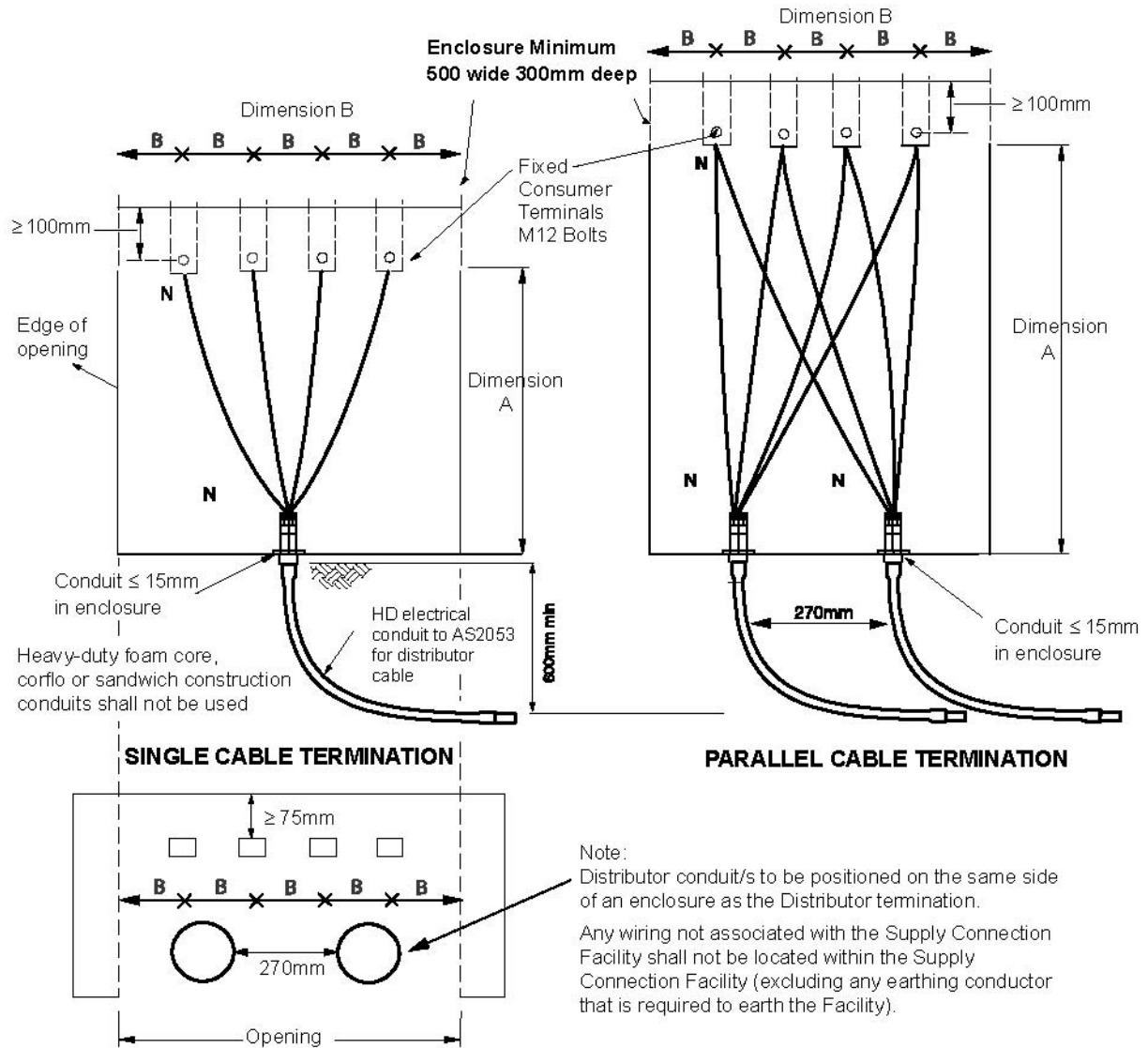

For Current Transformer Enclosures, refer also to Figure 8.11-E and 8.11-F for Minimum Current transformer Mounting Space.

Figure 7.3-B UG Service Cables – Supply Connection Facility Requirements **FAQ 011**

**7.3.2.5 Supply Protection Underground Service Cable Connected to an Underground or Overhead Distribution (No Pit)**

Unless otherwise agreed with or required by the relevant Distributor, where supply is provided from an Underground Service Cable the SPD shall be of a type and located in accordance with Table 7.3-2.

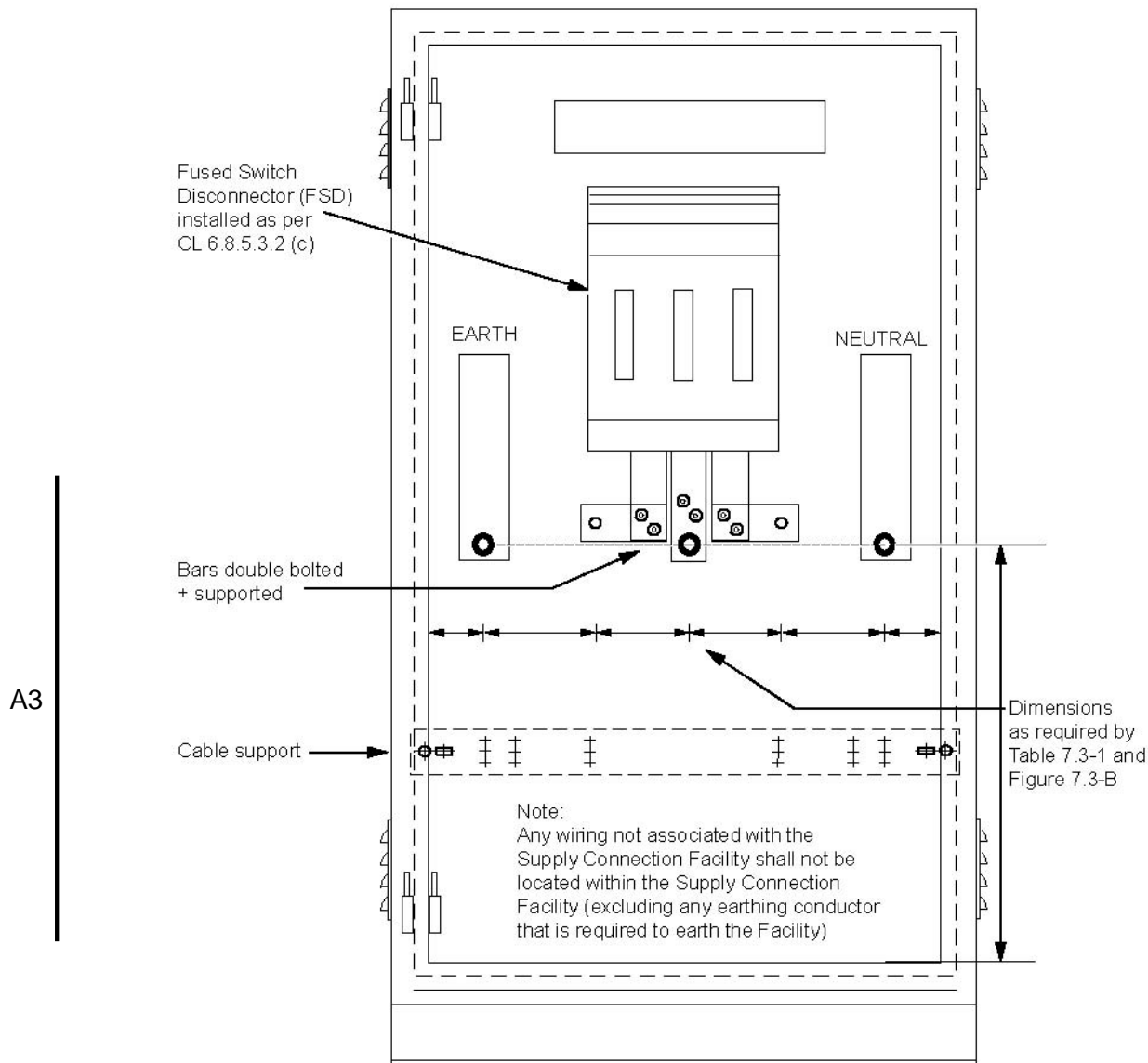

**Figure 7.3-C Typical FSD Termination Method**

A2

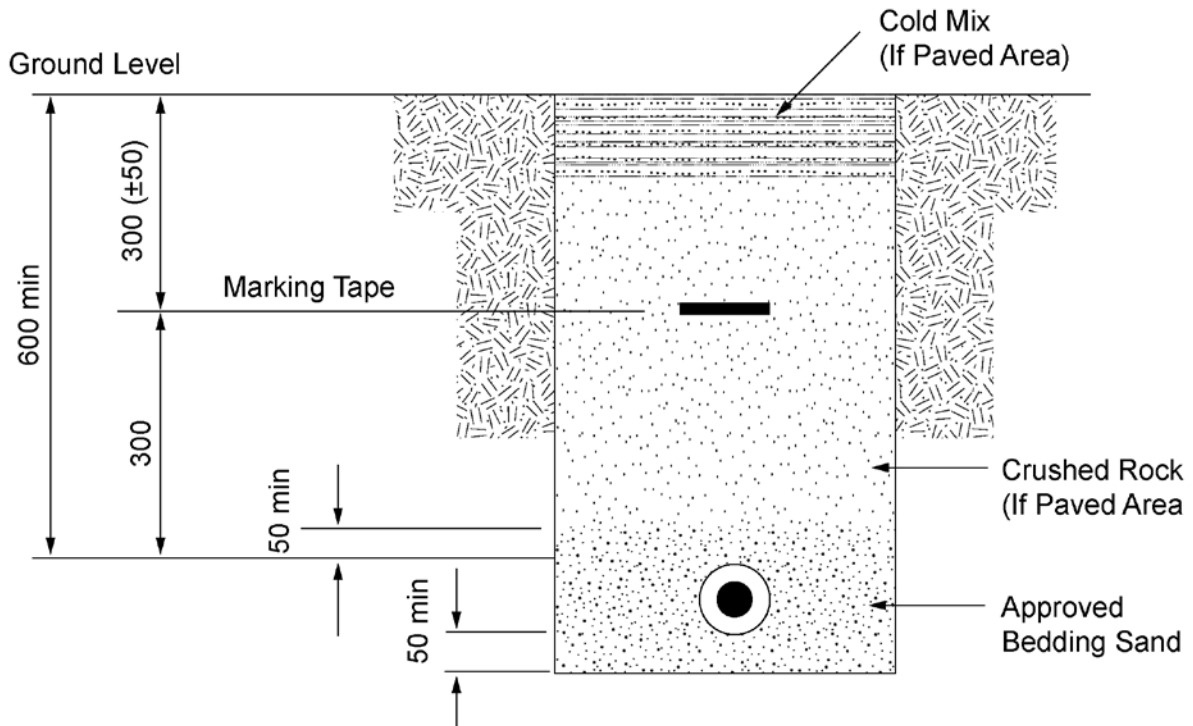

Typical Trench Section - 600 mm Minimum Cable Burial Depth

Note: Depth of conduit below ground can be > 600 mm, but marker tape shall be 300 mm above top most conduit.

The standard conduit used in the Distributors underground network is solid wall heavy duty unplasticised polyvinyl chloride polymer (UPVC) manufactured to AS/NZS 2053. The conduit wall thickness is to comply with the mechanical protection classification of heavy-duty, as defined in AS/NZS 2053. Heavy-duty foam core, corflo or sandwich construction conduits shall not be used.

**Figure 7.3-D Underground Network Conduit Installation Method**

**Table 7.3-2 SPD – Supply from an Underground Service Cable Connected to an Underground or Overhead Distribution (No Pit) FAQ 009**

Supply Current Rating Per Phase	Distributor Reticulation	Supply Protection Assemblies	Responsibility for the provision of Supply Protection Assembly	Supply Protection Device Types Provided by the Distributor	SPD location as Determined by the Distributor
A3 >100 A	NETWORK U/G	FSD	Customer	Sizes 00, 2 and 3 Din type NH fuses	1. As close as practicable to the applicable property boundary: or, 2. at or within 3m of the consumer's terminals (Supply Connection Facility) supplying UG consumer's mains: or, 3. in a position at or next to the Distributors metering equipment.
	O/H Areas				
	O/H Areas Note: (Dedicated service only)				
	UG Service supplied directly from a Substation				

## 7.4 Overhead Services

### 7.4.1 Provision

Apart from the exceptions listed below an overhead service cable may be provided where:

- The area is serviced by overhead network mains;
- Supply is available to suit the load; and
- The customer has provided facilities to meet the requirements of these Rules.

Exceptions are where:

- The customer cannot or does not provide facilities in accordance with these Rules;
- The demand exceeds 170Amps;
- The customer requests or is required to have an underground service pit or cable; and
- A private pole point of attachment is proposed in a hazardous bushfire risk area

Where the above exceptions apply, an underground service pit or service cable shall normally be required.

In all cases the type and installation of, and connection to an overhead service is subject to the agreement of the relevant Distributor.

Servicing arrangements should be confirmed with the Distributor prior to consolidating plans and the commencement of construction for its installation.

Failure to confirm servicing arrangements with the Distributor or comply with these Rules may result in refusal to permit and/or maintain an overhead supply.



## 7.4.2 Cables

Overhead service cables and continuous current ratings include but are not limited to:

- single phase, 25 mm<sup>2</sup> aluminium aerial service cable ≤80 Amps; per phase
- multiphase 25 mm<sup>2</sup> aluminium aerial service cable, ≤80 Amps per phase;
- multiphase 35 mm<sup>2</sup> aluminium aerial service cable, ≤95 Amps per phase;
- multiphase 95 mm<sup>2</sup> aluminium aerial service cable, ≤170 Amps per phase.

## 7.4.3 Consumer's Terminals

The consumer's terminals for an overhead service cable shall be:

- Compatible to the Distributor's service cable;
- Located in a position acceptable to the relevant Distributor;
- Located within or adjacent to the service protection device (SPD) enclosure; and
- Provided and maintained by the customer in a condition that allows the Distributor's service cable to be safely accessed, disconnected and reconnected. Eg. Fused Overhead Line Connector Box, Fused Switch Disconnecter,

Typical consumer's terminals and SPD locations are detailed in these Rules. The relevant Distributor will determine the location and type of consumer's terminals and SPD in situations not covered by these Rules.

## 7.4.4 Aerial Services

### 7.4.4.1 Application

This Rule applies to overhead service cables for:

- All new connections; and
- Alterations initiated by the customer for:
  - Replacement of mains from the consumer's terminals; and/or
  - Relocation of the point of attachment; and/or
  - Fault work due to a customer's electrical installations failure, actions or property that causes replacement of the un-metered portion of the consumer's mains or the relocation of the point of attachment; and/or
  - Failure to achieve and maintain service cable clearance in accordance with these Rules.

### 7.4.4.2 Aerial Service Types

#### 7.4.4.2.1 Standard Service

A standard aerial service is one where the cable is suspended between the Distributor's pole, and customer's Point of Attachment (POA). It is then connected to the consumer's terminals and supply protection device adjacent the POA.

A standard aerial service cable shall not exceed 45 m in length or 20 m suspended length over the customer's property.

#### 7.4.4.2.2 Mid-Span Service

An agreement between the customer and relevant Distributor is required for installation of a mid-span service as not all Distributors provide this type of service. Midspan services may be provided to premises located on the same side of the road reserve as the overhead reticulation and where clearances from other cable systems can be achieved.

A mid-span service is one that attaches to a catenary support cable or Aerial Bundled Cable (ABC) mains cable fixed between Distributor poles, and suspended between that cable and the customer's Point of Attachment (POA). It is then connected to the consumer's terminals and service protection device (SPD) adjacent to the POA.

Maximum suspended mid-span aerial service cables lengths are:

- Catenary Support – 35 m maximum length with 20 m maximum over property
- ABC Main Cable Support – 20 m maximum length

#### **7.4.4.3 Selection**

Aerial servicing arrangements shall be selected and nominated by the relevant Distributor in all cases. Confirmation of these arrangements shall be obtained where:

- The conditions required for its installation by these Rules may not be met;
- An electrical installation on a corner allotment has potential to be serviced from either street;
- A standard service from an urban pole type substation is considered;
- A mid-span service is considered;
- The customer requests the Distributor to consider installation of a service pole;
- Vegetation may encroach on the proposed service cable clearance space; and
- The service cable may pass over a roof or structure.

Note; Additional costs may be incurred by the customer where it is necessary for the Distributor to augment the network to achieve any of the servicing arrangements described above.

#### **7.4.4.4 Point of Attachment (POA)**

##### **7.4.4.4.1 General**

A Point of Attachment (POA) is the point at which an aerial service cable is attached to a service bracket at the customer's installation.

A customer shall provide a suitable POA in accordance with these Rules to enable installation of the cable.

Service brackets and their supports including private poles, supports, struts and extensions to buildings are required to comply with the Electricity Safety Act, Regulations and these Rules.

##### **7.4.4.4.2 POA Access**

The POA shall be safely accessible in accordance with the relevant requirements of the Occupational Health & Safety Regulations. To assist compliance with these Regulations, and provision of un-obstructed access to the POA, acceptable facilities shall be provided and maintained so the supply protection devices can be safely reached and operated in accordance with Clause 6.8.2.2 (Access), and the service cable can be installed and maintained safely:

- By a person standing on a portable extension ladder located upon the ground except as provided for in clause 7.4.4.4.4 (POA, Consumers Terminals and SPD's on Buildings) for a POA above a commercial premises veranda

In all cases the POA shall be provided with minimum portable extension ladder access facilities in accordance with Figure 7.4-A for set up of the ladder, ground conditions and acceptable support of the ladder head.

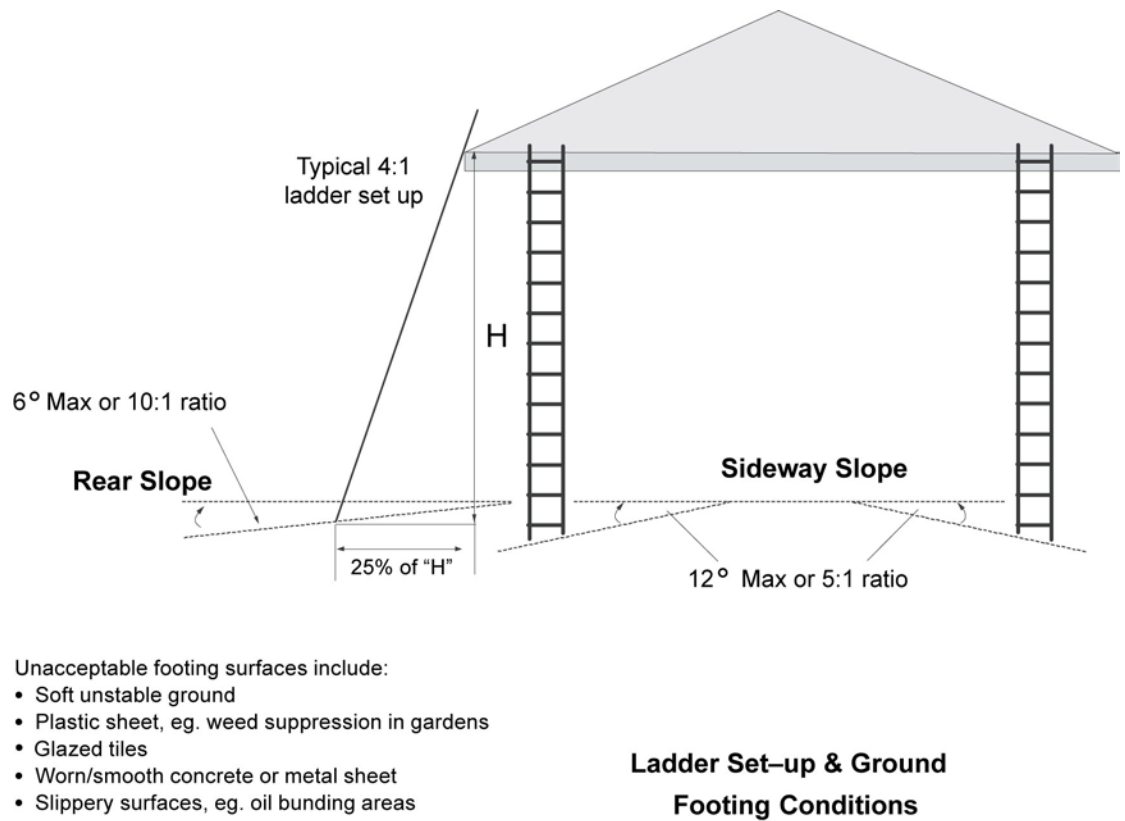

**Figure 7.4-A Minimum Portable Extension Ladder Access Facilities**

**7.4.4.4.3 POA Location**

The POA shall be installed in a location to enable the aerial service cable:

A3 |

- To meet all requirements of these Rules and the applicable Electricity Safety (General) Regulations;
- To avoid crossing above verandas and roofs unless this has been agreed by the relevant Distributor or is permitted by these Rules;

A3 |

- To avoid where practical the crossing of driveways, areas where vehicles may traverse within a property, swimming pools, structures and adjacent properties etc; and

A2 |

**7.4.4.4.4 POA, Consumers Terminals and SPD's on Buildings**

The POA on buildings shall be located on the foremost portion of the front of the structure facing the pole or point from where the aerial service cable originates, unless a more appropriate location is available, and in a position where the service cable can achieve and maintain all clearances.

A2 |

Agreement shall be obtained prior to consolidation of planning and commencement of work if the POA, Consumers Terminals and SPD's on Buildings is proposed on other than the foremost portion of the front of the structure.

A2 |

Clearances for POA, Consumers Terminals and SPD's on Buildings on buildings shall be in accordance with Figure 7.4.B and not be less than:

- 3.0 m from the ground;

- 3.0 m vertically and 1.0 m radially from any floor normally accessible to pedestrians, eg, veranda and balcony;
- 0.9 m radially from the boundary of any window, door or opening to 3.0 m above the floor on which a person may stand and extend an arm through the window, door or opening;
- 0.3 m from any window:
  - Through which a person cannot extend any part of an arm;
  - Which is above 3.0 m from the floor on which a person may stand; and.

A POA on a building shall not be higher than 6 m from the ground.

A POA shall not be installed above a veranda unless otherwise agreed with the relevant Distributor.

Where it is proposed that a POA is to be installed above a commercial premises veranda, it may only be accepted if the relevant Distributor has agreed, and the following conditions are met in addition to other applicable Rules:

- The POA is safely accessible in accordance with the Occupational Health & Safety Prevention of Falls Regulations and to the relevant Distributor's satisfaction;
- Provision is made for sealing to facilitate restriction to un-metered terminals in accordance with clause 6.8.5.1 (g) (SPDs and Assemblies – General Requirements);
- Stick operated fuses shall be located not less than 600 mm above the veranda;
- Meter Panel Isolation and Occupancy Disconnection Device/s (ODD) are installed in accordance with clause 8.10.2.11 Meter Panel Isolation and 8.10.2.12 individual ODD.
- The minimum veranda surface area in front of the POA is 2 m, and
- The fall of the veranda is no more than 7°.

#### 7.4.4.4(a)

#### **Under Veranda Distribution**

**FAQ 004**

Where there is an existing under veranda distribution arrangement, the Distributor shall be consulted to determine ownership and maintenance responsibilities.

A2

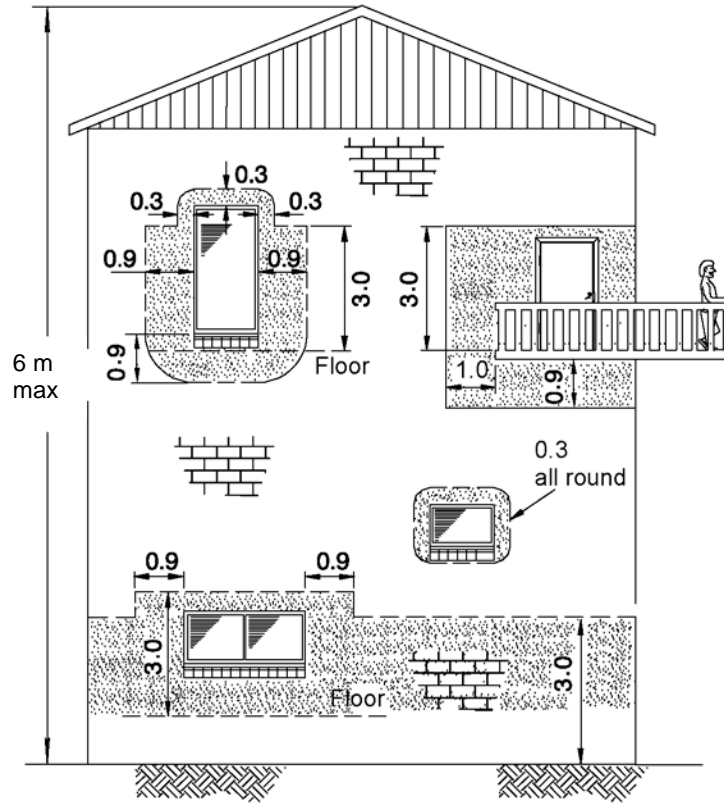

A3

On Buildings - Refer to Clause 7.4.4.4.4

**Restricted Areas**

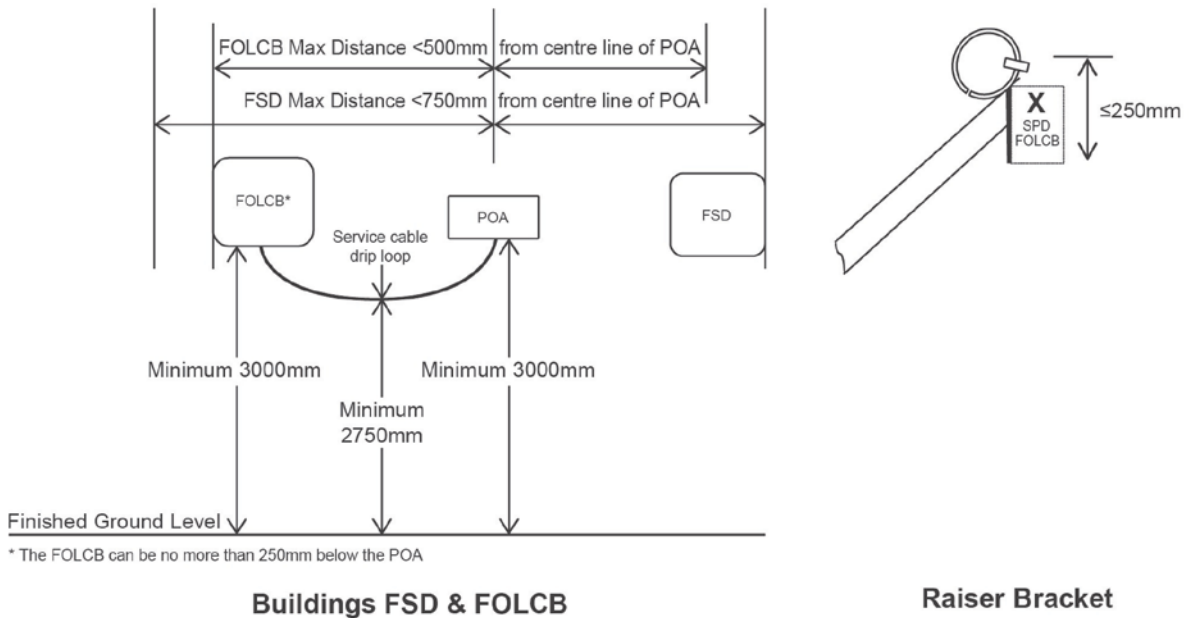

**Figure 7.4-B Buildings - POA, Consumer's Terminals & SPD Location**

7.4.4.4.5

**POA on Private Poles**

**FAQ 015**

The *Australian/New Zealand Wiring Rules* define the standard of construction and permitted locations for private poles, including builders supply poles. The *Electricity Safety Act* and *Regulations* restricts the construction or substantial reconstruction of private pole and *private aerial lines* in areas designated by the Country Fire Authority (CFA) as a hazardous bushfire risk area (HBRA).

**Areas not designated as a HBRA**

A point of attachment on a private pole is permitted provided it meets all other conditions of these Rules.

**Hazardous Bushfire Risk Areas**

A point of attachment is permitted on private poles that is a *transition pole private electric line*.

*transition pole private electric line* means a private electric line that consists of one private pole that—

- (a) supports the point of supply for that private electric line; and
- (b) other than a service line, is only connected to underground consumer's mains;

This may also include a *builder's supply pole*.

A point of attachment is not permitted on any private poles that is not a *transition pole private electric line* constructed or substantial reconstruction in a HBRA. In all circumstances, the relevant distributor shall be consulted to determine an appropriate supply method. Where due to extenuating circumstances, such as a major underground drain or channel obstructs an underground cable route, and where no other means of servicing is practicable, the customer may need to apply to ESV for an exemption to use a private pole or construct a private aerial line. The POA on a private pole shall be located to achieve or exceed the required clearances and ensure all other requirements of these Rules are met.

A3

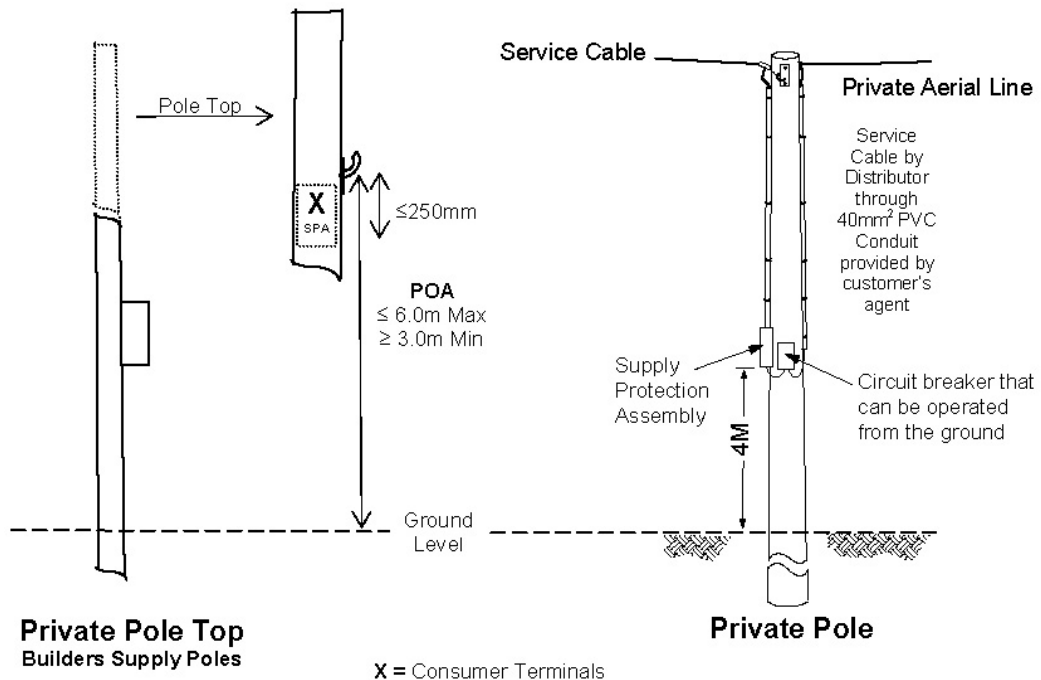

**Figure 7.4-C Private Poles - POA Consumer's Terminals and SPD Locations**

## 7.4.4.5 Service Brackets

### 7.4.4.5.1 General

All service brackets required by these Rules shall comply and be installed to comply with this specification and these Rules.

### 7.4.4.5.2 Provision

The customer shall provide, install and maintain a service bracket that complies with these Rules at the POA for the attachment of an aerial service cable.

### 7.4.4.5.3 Specification, Acceptance and Installation

#### (a) Definitions

**Service Bracket** – For the purpose of this specification there are two types of service brackets:

- i) **Standard Service Bracket** – A standard service bracket is defined as a bracket attached to a building or structure to provide a point of attachment for an overhead service cable at the point where the bracket is fixed, eg, house bracket, pole bracket and rafter bracket.
- ii) **Service Raiser Bracket** – A service raiser bracket is defined as a type of service bracket attached to a building or structure to provide a higher point of attachment for an overhead service cable than would be otherwise conveniently available using a standard service bracket. A Service Raiser Bracket does not include a strut or extension of a building.

#### (b) Hook

The hook shall be a minimum of 10mm in diameter and constructed so as to retain a service cable terminator on the hook throughout an arc of 60° in all directions from the normal without the terminator interfering with access to connection boxes or removal of their covers. The hook shall be able to accept closed hole and hook type service cable strain clamps. The 60° arc can be increased where the bracket incorporates a loop instead of a hook and additional bracing to meet the brackets load requirements in accordance with the manufacturer's instructions.

#### (c) Strength Rating

Service bracket hooks shall have a minimum installed safe working load (SWL) of:

- 1 kN for 2 wire service cables; and
- 2 kN for 3 and 4 wire service cables <35 mm<sup>2</sup>; and
- 4 kN for 95 mm<sup>2</sup> 4 wire service cables

Note; 95 mm<sup>2</sup> 4 wire service cables shall not be attached to a service raiser bracket.

The hook strength rating shall be met throughout an arc of 60° in all directions from the normal and all service brackets shall be of sufficient strength to withstand twice the hook's SWL without fracture or permanent deformation.

When installed in accordance with its installation instructions service brackets shall be of sufficient strength to withstand twice their safe working load without fracture or permanent deflection in excess of 3°.

#### (d) Marking

Service brackets that are required to be accepted shall be clearly and permanently marked with:

- Their strength rating (SWL);

- Manufacturer identification and Catalogue Number, and
- SIR Acceptance Number.

These markings shall be readily and clearly visible to a person adjacent to the bracket with the bracket in service.

**(e) Corrosion Resistance**

The corrosion resistance of all components of a service bracket shall be not less than that provided by galvanising in accordance with Australian Standard 4680 Hot Dipped Galvanised (Zinc) Coatings on Fabricated Ferrous Articles, Australian Standard 4791 Hot Dipped Galvanised (Zinc) Coatings on Open Section Ferrous Articles, Australian Standard 4792 Hot Dipped Galvanised (Zinc) Coatings on Hollow Section Ferrous Articles and Australian Standard 1214-1983 (Hot-Dip Galvanised Coatings for Threaded Fasteners – ISO Metric Coarse Thread Series).

**(f) Prevention of Conductor Insulation Damage**

There shall be no sharp edges and projections that the service or consumer's mains cables may come in contact with whether on external or internal surfaces. The connection box mounting plate shall not protrude beyond the edge of the connection box.

The service bracket shall be constructed and installed in a manner to enable the service cable and equipment to maintain clearance from the connection box and bracket in situ, and for all connection box access covers to be removed without the necessity for the covers to contact the service cable or equipment.

**(g) Provision for Earthing**

Service *raiser* brackets shall be provided with a flag terminal with a hole sized to accept a M10 hot dipped galvanised bolt, washers and nut for connection of an earth bonding cable.

**(h) Equipment Access**

The service bracket and consumer's terminals and equipment shall be safely accessible in accordance with clause 7.4.4.4.2 (POA Access).

**(i) Installation**

Service *raiser* brackets that are required to be accepted shall be supplied with the manufacturer's recommended installation instructions. The instructions shall include the SIR acceptance number and sufficient detail for the bracket to meet the strength and other requirements detailed in this specification when it is installed in accordance with the instructions.

The service *raiser* bracket shall be installed in accordance with the manufacturer's installation instructions.

Standard service brackets are to be installed in accordance with Figure 7.4-D and of these Rules or an equivalent standard.

**(j) Acceptance of Service Brackets**

- i) *Standard* service brackets and service raiser brackets that are not required to be accepted in accordance with Clause 5.3.1 (Equipment Required to be Accepted) shall meet the requirements of clause 5.3.2 (Equipment Not Required to be Accepted). The electrical contractor responsible for the electrical installation shall furnish proof, if requested to do so by the relevant Distributor, that a bracket meets the requirement of this specification.



- ii) Any service *raiser* bracket required to be accepted by Clause 5.3.1 (Equipment Required to be Accepted), shall be accepted for use by the following type test process prior to installation:
- Unless otherwise agreed, the documentation specified in Table 7.4-1 and a sample bracket shall be submitted to the nominated Rules Management Committee representative prior to the bracket's installation.
  - Provided the documentation and results are acceptable, the committee will provide a letter of acceptance for use, and that type service raiser bracket may be installed.

Failure to follow this process will usually result in the Distributor's refusal to connect to the bracket.

**Table 7.4-1 Service Raiser Bracket Acceptance Documentation**

Documents		Certification
S U B C L A U S E	b) Hook	By a suitably qualified engineer or party. (Strength rating may be by test or computation)
	c) Strength Rating	
	d) Marking	By a suitably qualified electrical approvals consultant or party.
	f) Prevention of conductor insulation damage	
	g) Provision for Earthing	
i) Installation Instructions	By the equipment galvaniser or other suitable party.	
e) Corrosion Resistance		
	h) Equipment Access	By a suitably qualified Occupational Health & Safety Practitioner or party.
Engineering drawings detailing materials and dimensions		By the manufacturer or their representative.
Photos of strength rating marking and the installed bracket		
A manufacturers compliance declaration		

#### 7.4.4.5.4

#### One Off Brackets

Brackets manufactured for an individual installation (one off) shall have documentation provided as required by Table 7.4-1 prior to their installation. The Responsible Officer will determine the suitability after reviewing the documentation.

A3

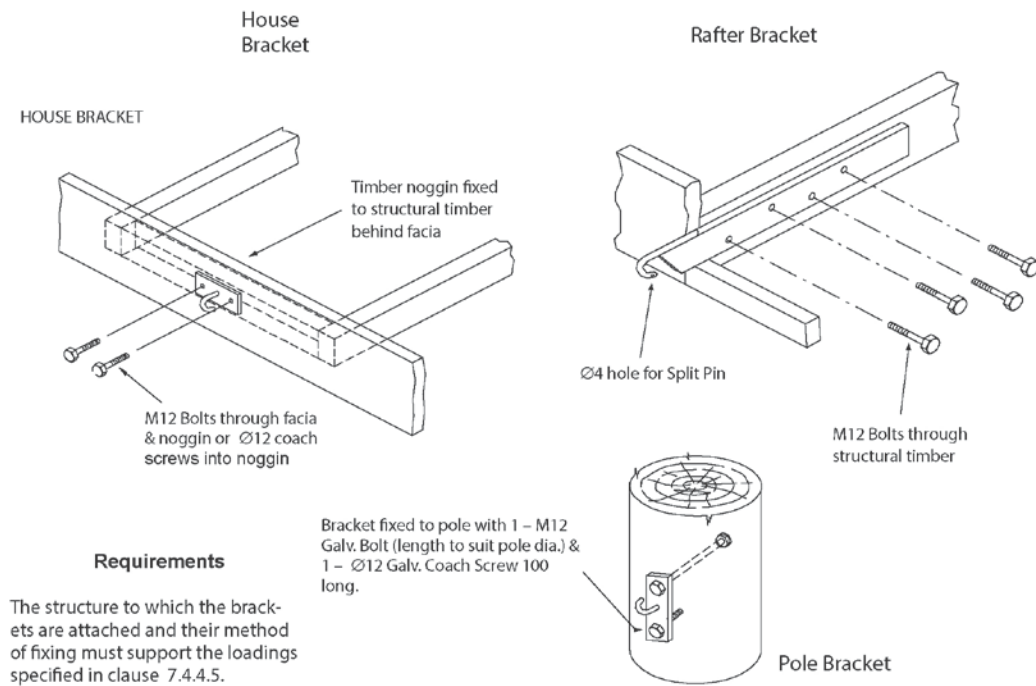

**Figure 7.4-D Standard Service Bracket Fixing**

## 7.4.4.6 Aerial Service Line Clearances

### 7.4.4.6.1 General

Aerial service lines shall be installed and maintained to ensure the minimum clearances specified by these Rules and Regulations at the time of the service line's installation and the current Electricity Safety Act (including the current Code of Practice for Electric Line Clearance (Vegetation)) are not breached.

Lines installed in accordance with Clause 7.4.4.1 (Application) are required to meet the minimum clearances specified in Figure 7.4-E, Figure 7.4-F and these Rules.

Clearances in excess of the minimum clearances specified by the Electricity Safety Act and Regulations will be required in situations not covered by these Rules, eg, channels.

Although Distributors have the primary responsibility for aerial service lines, both the Distributor and Customer have responsibilities to enable these clearances to be achieved and maintained.

### 7.4.4.6.2 Customer's Obligations

**FAQ 002**

The customer is responsible to:

- Provide a point of attachment and arrangements on their property to ensure the service line clearances are achieved and maintained in accordance with the conditions of these Rules, Electricity Safety Act, Regulations; and
- Ensure that modifications to the property they occupy do not breach these Rules, Electricity Safety Act and Regulations for clearances from ground, structures, objects, trees and vegetation to the service cable supplying the property.

A Distributor may agree to a customer's request to install a service pole or mid-span service or provide other works at the customer's expense to gain the required clearances within the customer's property.

Where the customer is unable or fails to provide facilities for the cable to meet and maintain the required clearances within their property in accordance with these Rules, the property shall be supplied by an underground service cable at the customer's cost.

A3 | If the customer fails to maintain clearances prescribed by Electricity Safety (General) Regulations from trees or vegetation within their property to the aerial service cable supplying the property, the Distributor may clear those trees or vegetation in accordance with the Electricity Safety Act and Code of Practice for Electric Line Clearance (Vegetation) at the customer's expense.

The customer shall advise the Distributor where alterations to their point of attachment or property may in any way affect the clearances of an aerial service cable.

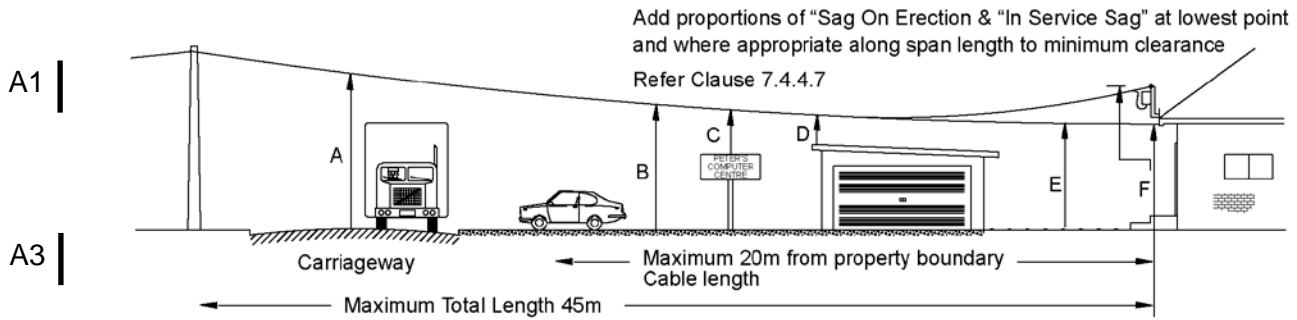

AREA	MINIMUM CLEARANCE
A. Above a public roadway**	
• Over a 2000mm wide strip in the centre of each carriageway of a roadway and over any other part of a freeway, primary road or highway.	5500mm
• Over any other part of a secondary road, or collector road.	4900mm*
• Over any other part of any other road.	4900mm*
B. Over driveways and ground traversable by vehicles, ie, customers property which a vehicle may enter or cross without impediment.	4600mm*
C. Over any existing structure or part of an existing building on which a person cannot stand e.g., sign, mask, blank wall, fence	500mm
D. Over those parts of an existing building or structure - not normally accessible to persons but on which a person can stand. e.g car-port, pergola, veranda. Note: any new structure under an existing aerial line must be compliant with the clearances in the Electricity Safety (General) Regulations.	500mm
E. Elsewhere eg. areas other than those above which are not traversed by vehicles.	3000mm
F. At the Point of Attachment.	3000mm

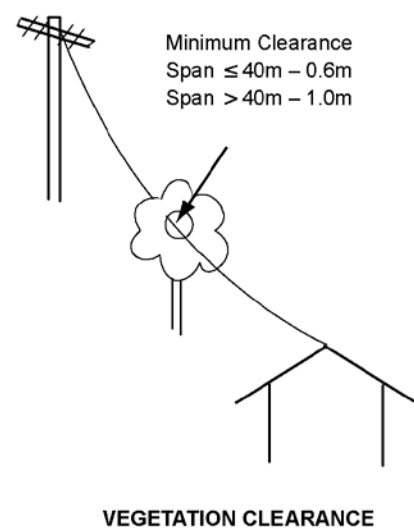

**NOTES**

Where a Distributor has an Electricity Safety Management Scheme the Clearances may vary from these specifications.

\* These clearances are increased to 5000mm in Broad Acre Areas defined By Vic Roads. These areas are the municipalities of Mildura, Hindmarsh, West Wimmera, Horsham, Northern Grampians, Loddon, Gannawarra, Swan Hill, Buloke, and Yarriambiak.

\*\* Refer to Melway's Street Directory and Vicroads Country Directory for public roadway definitions.

**Figure 7.4-E Common Minimum Service Cable Clearances**

**7.4.4.7 Service Cable Sag**

Service cables will sag after erection due to temperature rise and construction loadings.

Appropriate proportions of the "Sag on Erection" (normal sag) and the "In-service Sag Allowance" shall be allowed for to ensure minimum clearances are met at all times. Refer to Table 7.4-2 and Figure 7.4-F.

Example: Span length 35 m of 4 x 25 mm<sup>2</sup>

Sag on Erection 1160 mm + In-service Sag Allowance 360 mm = 1520 mm

Where the termination points are level, allow a minimum total service cable sag of 1520 mm in the centre of the service cable below a straight line between the termination points.

The location and proportion of service cable sag will vary according to the angle of the termination points.

**Table 7.4-2 Service Cable Sag**

Cable Type	2, 3, x 25 mm & 4 x 35 mm		4 x 95 mm	
	(≤ 80 Amps)	(≤ 95 Amp)	(≤ 170 Amp)	
Span Length (m)	Sag On Erection* (mm)	In-service Sag Allowance** (mm)	Sag On Erection* (mm)	In-service Sag Allowance** (mm)
10	150	230	130	230
15	300	260	280	260
20	510	290	500	270
25	620	330	780	280
30	870	350	1110	300
35	1160	360	1510	300
40	1500	370	1980	300
45	1880	380	2500	310

\* Sag on erection (ie, no electrical load) at assumed ambient of 15°C

\*\* The in-service sag allowance is the sag at lowest point in span due to cable stretch, loaded temperature rise and pole movement. If the point of consideration is other than the lowest point of the line then proportional allowance may be made.

A3 |

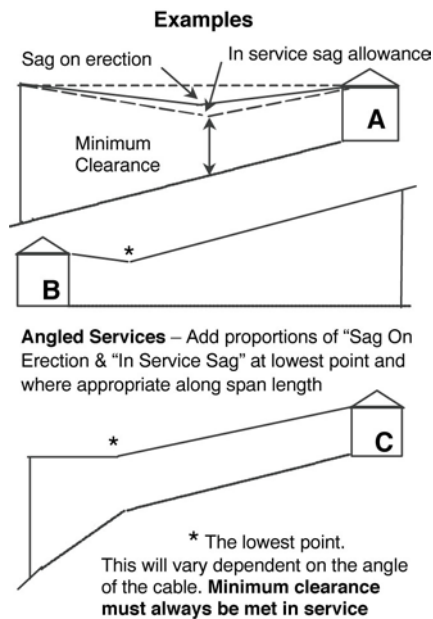

**Figure 7.4-F Service Cable Sag**

## 7.4.4.8 Service Cable Routes

### 7.4.4.8.1 Existing Installations

A service cable route which encroaches over an adjacent property can be retained in its present location where it is unlikely to be subject to any risk of obstruction by vegetation, structures, buildings, etc.

Installations currently connected to supply and undergoing repair following a fault or customer initiated work, the following requirements shall be adopted in circumstances where it is proposed to retain the service cable route in its present position;

- Property crossings shall be avoided or minimised where practical, or
- Relocate the current point of attachment to improve the service cable route where practical
- Minimum service cable heights from the ground are not less than permitted under the Electricity Safety (Management) Regulations (consult with the relevant Distributor)
- Where an existing service cable crosses a swimming pool or spa, the service cable is to be relocated to avoid crossing the swimming pool or spa

A2

Refer to Figure 7.4-G

### 7.4.4.8.2 New Installations

A service cable over an adjacent property will only be permitted where it is unlikely to be subject to any risk of obstruction, and where the service cable will not encroach over more than 25% of the length of the front boundary or 2 m of the side boundary of the adjacent property.

Where practical the service cable route shall be selected to avoid the necessity for the service cable to cross over roads, driveways, areas where vehicles may traverse, roofs, structures and adjacent properties.

A2

Service cables shall not be located over swimming pools or spas

Refer to Figure 7.4-G

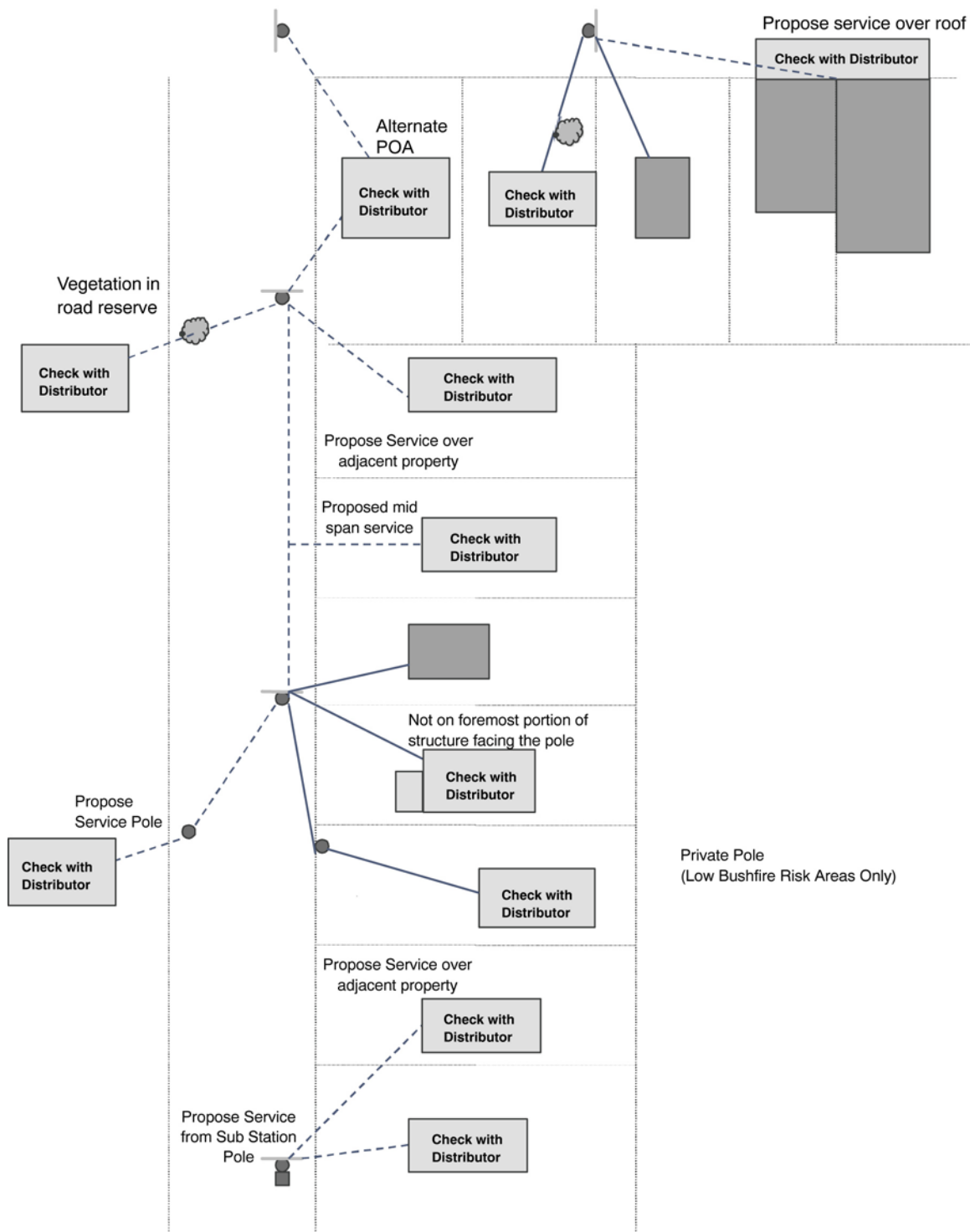

**Figure 7.4-G Service Cable Routes**

### 7.4.4.9 Supply Protection Aerial Service Cable

Unless otherwise agreed with or required by the relevant Distributor, where supply is provided from a Overhead Aerial Service Cable the SPD shall be of a type and located in accordance with Table 7.4-3.

**Table 7.4-3 SPD – Supply from an Aerial Service Cable**

Supply Current Rating Per Phase	Supply To	Supply Protection Assemblies	Responsibility for the provision of Supply Protection Assembly	Supply Protection Device Types Provided by the Distributor	SPD Location
1 Ph $\leq 80A$	Building or Structure	FOLCB	Customer	Type 2a Fuse	In accordance with Figure 7.4-B See Note <sup>1</sup>
$\leq 100A$		FSD	Customer	Sizes 00, 2 and 3 Din type NH fuses	
$>100A \leq 170A$		FOLCB	Customer	Type 2a Fuse	
$\leq 100A$	Private Pole (On Private Property in Low Bushfire Risk Areas)	FSD	Customer	Sizes 00, 2 and 3 Din type NH fuses	In accordance with Figure 7.4-C
$>100A \leq 170A$		FSD	Customer	Sizes 00, 2 and 3 Din type NH fuses	

Note<sup>1</sup> Where agreed and installed above commercial premises veranda in accordance with the current rules (POA on Buildings) additional requirements are that fuses can be operated with a 600mm vertical standard fuse stick, sealing facilities are provided to restrict access to un-metered terminals, and Occupancy Disconnection Devices are provided in accordance with Section 8.

## 7.5 Un-metered Consumer's Mains & Sub-Mains

### 7.5.1 Cables & Conductors

#### 7.5.1.1 General

The customer shall provide, prepare and maintain their consumer's mains and sub-mains cables and conductors at the interface and termination to Distributors equipment in accordance with these Rules.

The type and size of these cables and conductors should be selected and prepared with consideration to the requirements of the Electricity Safety Act and Regulations and these Rules.

These Rules cover the most common types of mains and sub-mains which interface with Distributors equipment, and do not cover some arrangements such as Earthed Sheath Return (ESR) and some fire rated systems.

The relevant Distributor shall be consulted where the suitability of proposed cables and conductors and their termination are not covered by these Rules or is in doubt.

#### 7.5.1.2 Conductor Types

Insulated multi strand soft drawn copper conductors shall be provided to terminate into Distributors service and metering equipment. The conductors may be compressed and/or compacted provided they comprise annealed copper.

- Conductors  $\leq 16 \text{ mm}^2$  shall have a minimum of 7 strands
- Conductors  $\geq 25 \text{ mm}^2$  shall have a minimum of 18 strands

Where non-compliant conductors are installed, they shall be converted to compliant conductors external to the enclosure containing the Distributors' equipment.

### 7.5.1.3 Conductor Sizes

Clause 8.9.3.2 (Meter Wiring) specifies that conductor sizes for termination to meters shall be a minimum of 4mm<sup>2</sup> and a maximum of 35mm<sup>2</sup> for load carrying conductors and 2.5mm<sup>2</sup> for control wiring.

Clause 7.5.2.4 (Termination Within a Service Pit) specifies that conductors for termination within service pits shall be a minimum size of 6 mm<sup>2</sup> for any service pit, and a maximum of 35 mm<sup>2</sup> for a shared service pit and a maximum of 50 mm<sup>2</sup> for a dedicated service pit.

### 7.5.1.4 Colours & Double Insulation

#### 7.5.1.4.1 General

Cables and conductors at consumer's terminals and metering facilities shall be permanently colour coded and double insulated where required by these Rules.

Double insulation is required for conductors where required by the Regulations, Wiring Rules and these Rules, eg, Refer Clause 7.5.2.4 (Termination within a Service Pit).

#### 7.5.1.4.2 Colour Codes & Sleeving

Conductor colour codes shall be:

Neutral Conductor - Black.

1st Active Conductor – Red

2nd Active Conductor – White

3rd Active Conductor - Blue

Where the colour codes of cables and/or conductors and/or double insulation of conductors are not in accordance with these Rules they shall converted to comply by heat shrink sleeving, fixed sleeving or elastic sleeving in accordance with the Wiring Rules and these Rules. Insulation tape is not acceptable.

Colour coding and double insulation of specific cables and conductors shall be achieved as follows:

#### 7.5.1.4.3 SDI Cables (Single Double Insulated)

If the conductor insulation forming a single double insulated cable sheath has the correct phase and neutral colour, eg, black for a neutral conductor and red for an active conductor, and where it is not necessary to remove the cable sheath for connection into service pits and neutral links and fuses at meter panels, at least 100 mm of black and red sleeving respectively shall be applied to the sheath of the cables from approximately 250 mm to 150 mm from the end of the cable. White and blue sleeving may be applied within the same dimensions to identify the second and third active cables provided the conductor insulation is of an active colour that complies with the Wiring Rules.

Where the conductor insulation is not of a colour that complies with the Wiring Rules, the sheath is to be removed for its entire length within the enclosure in which it is to be terminated and the conductor sleeved in accordance with these Rules. Double Insulation shall be reinstated where required.

#### 7.5.1.4.4 Single Insulated Cables with Reinforced Insulation (with or without a sheath)

If the insulation of the single reinforced insulated cable that has no sheath and is not of the correct colour, the cable shall be coloured within the enclosure in which it is to be terminated. At least 100 mm of black and red sleeving respectively shall be applied to the sheath of the cables from approximately 250 mm to 150 mm from the end of the cable. White and blue sleeving may be applied within the same dimensions to identify the



A3 | second and third active cables provided the conductor insulation is of an active colour that complies with the Wiring Rules.

**7.5.1.4.5 Sheathed Multi-core Cables (eg: Orange Circular) FAQ 005**

Where conductor insulation of multi-core double insulated cables is of the correct conductor polarity colour, no further preparation is needed where the sheath is removed and only single insulated properties of the conductor is required.

A2 | Where a conductor polarity is not correct, the conductor shall be sleeved for its entire length within the enclosure in which it is to be terminated and fitted with a crutch. Double Insulation shall be provided where required.

**7.5.1.4.6 Single Insulated Conductors**

Where the insulation of a single insulated conductor is not of the correct colour, the conductor shall be coloured in accordance with this Rule for its entire length within the enclosure in which it is to be terminated. Double Insulation shall be provided where required.

**7.5.1.5 Joints in Un-metered Cables & Conductors**

Joints in un-metered cables and conductors shall be made in such a manner as to deter unauthorised access, interference or diversion of electricity supply in accordance with Table 7.5-1 and to the satisfaction of the relevant Distributor.

**Table 7.5-1 Joints in Un-metered Cables & Conductors**

Joint Location	Acceptable jointing methods & location
Not readily accessible or visible, eg: <ul style="list-style-type: none"> <li>● Roof Space</li> <li>● In Wall</li> <li>● Underfloor</li> </ul>	<ol style="list-style-type: none"> <li>1. Joint enclosed in a suitable junction box filled with a hard setting, non conductive compound</li> <li>2. Crimp link joints enclosed with heavy wall mastic filled heat shrinkable tubing fitted over joints and original conductor insulation with a second layer fitted where double insulation is required.</li> </ol>
Visible and readily accessible position, eg: <ul style="list-style-type: none"> <li>● Adjacent the meter position</li> <li>● On a pole or wall</li> <li>● Above ground</li> </ul>	<ol style="list-style-type: none"> <li>1. Joint enclosed in a suitable junction box with provision to fit a Distributors seal.</li> <li>2. Crimp link joints enclosed with heavy wall mastic filled heat shrinkable tubing fitted over joints and original conductor insulation with a second layer fitted where double insulation is required.</li> <li>3. Within a pillar with sealing or locking facilities in accordance with Clause 5.6 (Sealing and Locking)</li> </ol>
Behind a hinged meter panel	Meter panel with provision to fit a Distributors seal
Underground	<ol style="list-style-type: none"> <li>1. Joint enclosed in a suitable junction box or similar enclosure filled with a non conductive, non hydroscopic compound</li> <li>2. Crimp link joints enclosed with heavy wall mastic filled heat shrinkable tubing fitted over joints and original conductor insulation with a second layer fitted where double insulation is required.</li> <li>3. Within an approved pit.</li> </ol>

**7.5.2 Underground Mains and Sub-Mains**

**7.5.2.1 Insulation Resistance of Underground Consumer's Mains**

A3 | (1) Before consumer's mains are first placed into service or use, the insulation resistance—

- (a) between the conductors of underground consumer's mains; and

- (b) between the conductors of underground consumer's mains and earth; and
- (c) if the consumer's mains conductors are surrounded by a metallic sheath, between the conductors of underground consumer's mains and the metallic sheath—

must not be less than the relevant minimum insulation resistance specified in column 2 of Table 7.5.2.1-A when tested with a 500V d.c. insulation resistance tester.

- (2) When existing underground consumer's mains are reconnected to electricity supply, the insulation resistance—
- (a) between the conductors of underground consumer's mains; and
- (b) between the conductors of underground consumer's mains and earth; and
- (c) if the consumer's mains conductors are surrounded by a metallic sheath, between the conductors of underground consumer's mains and the metallic sheath—

must not be less than one megohm when tested with a 500V d.c. insulation resistance tester.

**Table 7.5.2.1-A Minimum Insulation Resistance of Underground Consumer's Mains**

Route length of underground consumer's mains	Minimum insulation resistance
≤ 50 m	50 megohms
> 50 m and ≤ 75 m	45 megohms
> 75 m and ≤ 100 m	40 megohms
> 100 m and ≤ 125 m	35 megohms
> 125 m and ≤ 150 m	30 megohms
> 150 m and ≤ 175 m	25 megohms
> 175 m and ≤ 200 m	20 megohms
> 200 m and ≤ 225 m	15 megohms
> 225 m and ≤ 250 m	10 megohms
> 250 m	5 megohms

### 7.5.2.2

#### Wiring Systems

Underground consumer's mains and sub-mains are required to be installed in accordance with the Electricity Safety Act and Regulations and these Rules and installed in manner to reduce the risk of short circuit occurring and accidental damage to the conductors.

Double Insulated Single and Multi-Core cables with stranded copper conductors and elastomer, thermoplastic or XLPE insulation and sheathing, enclosed in heavy duty non-metallic conduit is the most common acceptable arrangement for underground metered and un-metered consumer's mains and sub-mains. It is also the preferred arrangement.

The route of mains and sub-mains shall to the extent that is practicable, be selected so as to avoid substation earthing systems and other electricity network and utilities assets.

Where a common trench contains un-metered cables, these cables should be laid below other services and the trench partially backfilled prior to installing other services, and the requirements of other authorities for use of a common trench should be met.

To optimise safety and the operation of electrical protection upstream of the mains or sub-mains in the event of a short circuit between conductors or earth the following arrangements shall apply:

- Where installed within a non-metallic conduit or pipe all conductors shall be contained within the one pipe or conduit, except as provided below:

- Not less than two conductors of different phase or polarity are contained within the one conduit and the conduits follow substantially the same route; or
- Where single conductors are installed in individual conduits or buried direct, the conduits or cables buried direct shall be securely lashed together to form a bundle; and
- Cables smaller than 95 mm<sup>2</sup> shall not be installed buried direct.

The customer's REC shall take precautions to arrange underground enclosures in a manner that will prevent moisture entering the building via the enclosure; particularly where a pit is installed at a higher level than the entry to the building. This may be achieved by sealing the conduit at the pit and installing conduit draining facilities above the level that it exits the ground.

### 7.5.2.3 Backfilling

Trenches containing underground wiring shall be adequately backfilled before they are energised.

### 7.5.2.4 Termination within a Service Pit

Consumer's mains to be terminated in service pits shall be installed and prepared by the customer's agent in accordance with this clause, Figure 7.5-A and Clause 7.5.1 (Cables & Conductors).

Any cables and equipment within a service pit shall be treated as ALIVE and shall not be handled without taking appropriate safety precautions.

Conduits shall extend a maximum of 100 mm into the pit.

The maximum numbers of consumer's mains conductors that may be connected within a service pit are:

- dedicated pit - one set of 50 mm<sup>2</sup> consumer's mains
- shared pit – 2 sets  $\leq$  35 mm<sup>2</sup> consumer's mains

Only copper double insulated consumer's mains not smaller in size than 6 mm<sup>2</sup> and not greater than 50 mm<sup>2</sup> shall enter or be connected in a service pit.

The conductors shall extend to a minimum of 1.0 m above the top of the pit, and conductor end/s shall be sealed to prevent the ingress of moisture.

The cables or conductors for each set of mains shall be tied together, identified with a permanent water resistant tag at or below ground level and left neatly coiled within the pit. The tag shall be permanently marked specifying the lot or street number of the premises it supplies.

Ensure the cables are safely coiled at the base of the pit before replacing the pit lid.

### 7.5.2.5 PVC Service Pits

**FAQ 001**

PVC service pit bases are manufactured with 3 x 100 mm apertures. One for the incoming Distributors service cable and two as provision for 63 mm diameter lead in conduits to each customer.

PVC service pits shall not be modified. This includes creating additional apertures or shortening or increasing the pit depth.

Where necessary, 6 mm and 10 mm riser rings are available for the distribution business to raise pit openings to the finished surface level.

A2

A2

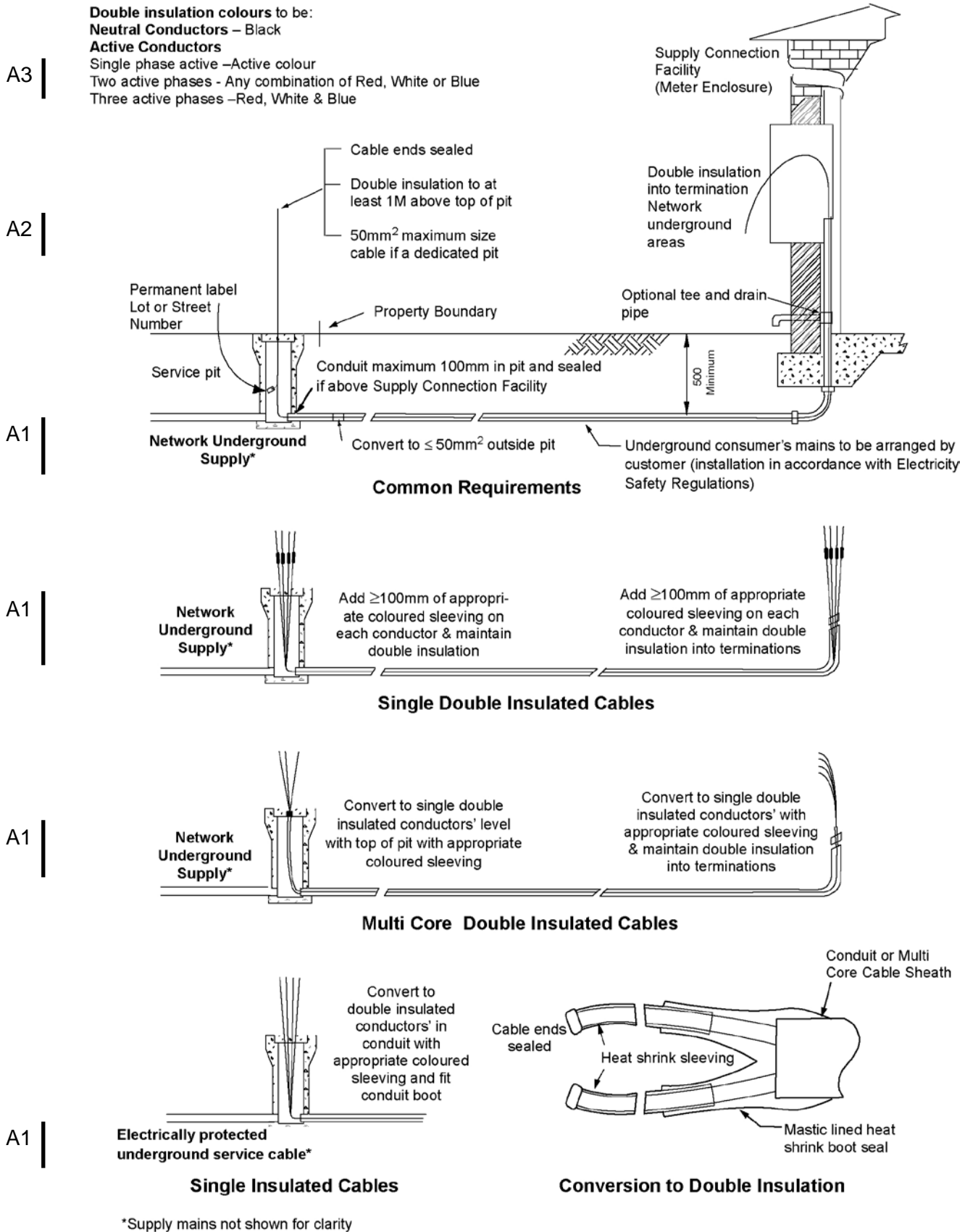

**Figure 7.5-A Requirements for Consumer's Mains Supplied from a Service Pit**

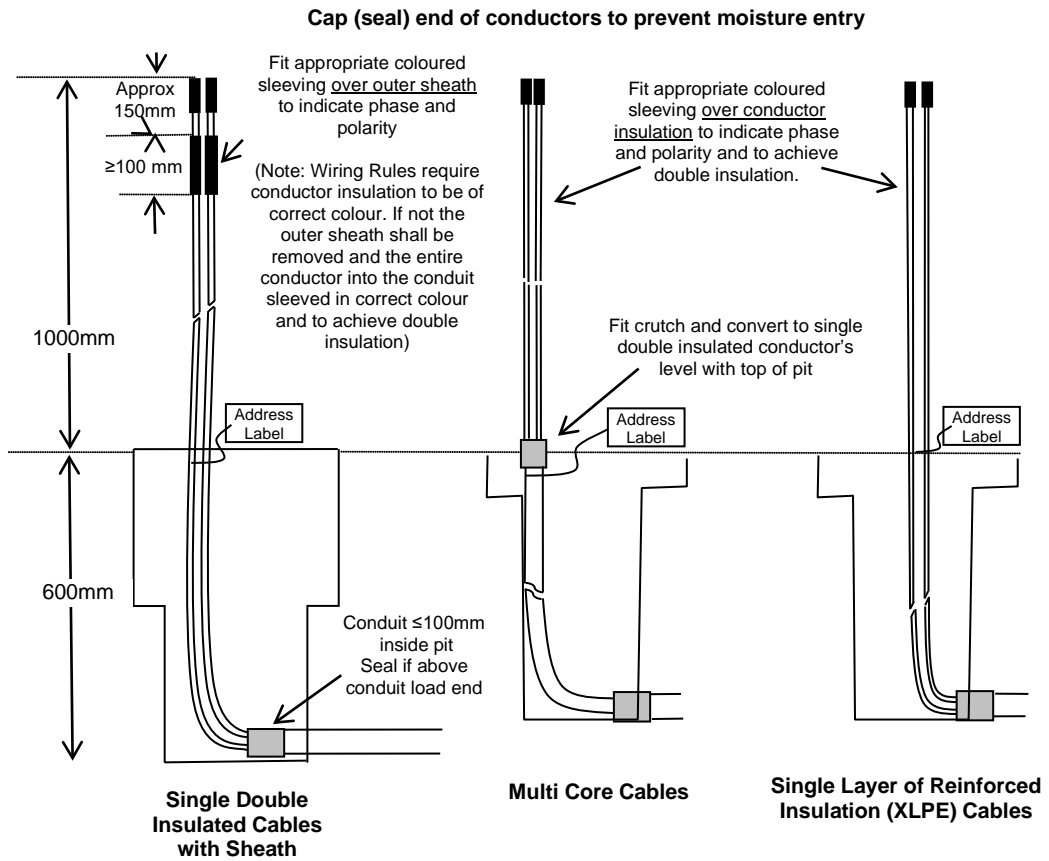

**Figure 7.5-B Consumer's Mains Termination – Service Pit**

### 7.5.3 Termination at Indoor, Kiosk and Ground Type Sub-Stations

The relevant Distributor will in all cases provide specific conditions and requirements for consumer's mains to be installed and terminated to a indoor, kiosk and ground type Distributor's sub-station. In all cases the following applies unless otherwise advised:

- The customer's agent shall comply with the relevant Distributors conditions for installation of the consumer's mains and access into the sub-station and it's enclosure;
- The consumer's mains route and installation and termination arrangement within the substation easement shall be agreed with the relevant Distributor prior to its installation;
- The customer's agent is responsible to install and prepare the consumer's mains in the agreed manner in readiness for connection by the Distributor
- Consumer's mains shall be double insulated cables or busbar;
- Entry of the consumer's mains into an indoor substation enclosure shall be sealed with an approved sealing system with a fire rating of at least two hours; and
- Any conductive cable tray or support within a substation enclosure shall be electrically isolated from those outside the enclosure.
- Refer to the relevant Distributor for the maximum size and maximum number of conductors able to be terminated

A3

A3

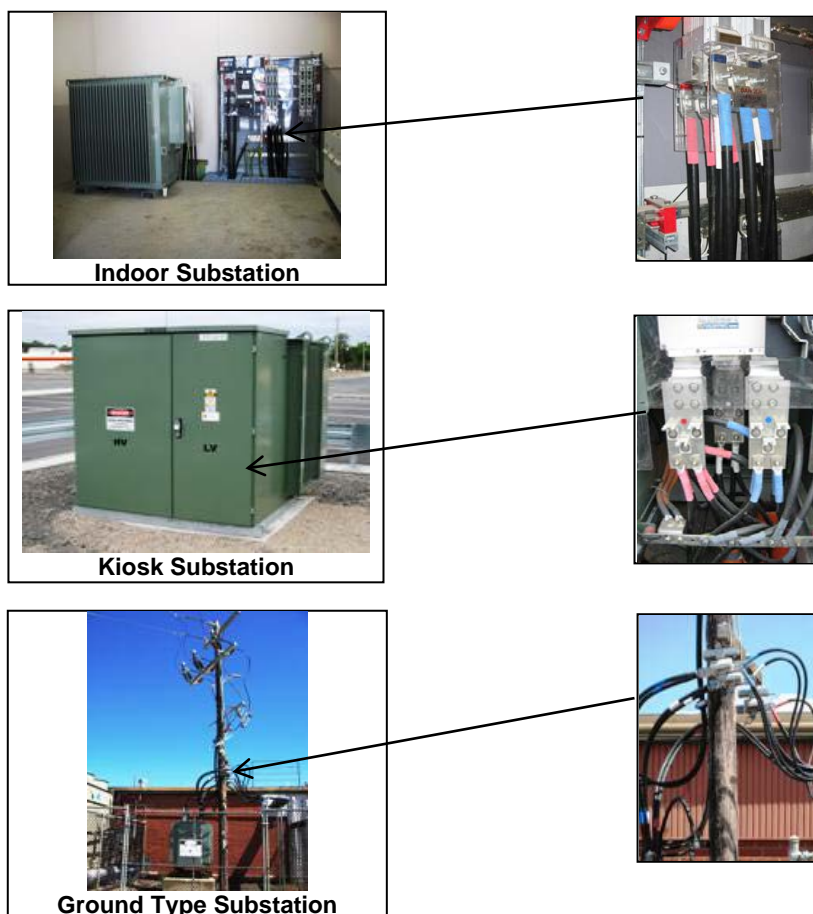

**Figure 7.5-C Typical Consumer's Mains Terminations to Distributors Sub-Stations**

### 7.5.3.1 Supply Protection, Indoor, Kiosk or Ground Type Substations

Unless otherwise agreed with or required by the relevant Distributor, in cases where the electricity supply is provided directly from a substation located within the property it supplies, the Service Protection Assembly Devices shall be selected and located in accordance with Table 7.5-2.

**Table 7.5-2 SPD – Supply from an Indoor, Kiosk, Ground or Pole Type Substation Located Within the Property it Supplies**

Supply Current rating Per Phase	Substation Type	Supply Protection Assemblies	Responsibility for the provision of Supply Protection Assembly	Supply Protection Device Types Provided by the Distributor	SPD Location
>100 A	Kiosk, Indoor, Ground Type	FSD MCCB ACB HV Protection	Distributor	Sizes 00, 2 and 3 Din type NH fuses	Installed within the Substation See Note <sup>1</sup>
				MCCB	
				ACB	
				HV Protection	
≤ 100 A	Pole Type <sup>2</sup>	FOLCB	Customer	Type 2a Fuses	On Distribution Company Pole
> 100 A		FSD		Sizes 00, 2 and 3 Din type NH fuses	
In some cases, Distributor's may utilise their HV protection equipment for service protection. It will be necessary to confirm the service protection arrangement with the relevant Distributor at the design stage of the electrical installation.					
Note <sup>1</sup> Electricity Safety (General) Regulations Reg 303(4) allows for HV protection in certain circumstances (3) In the case of electricity supplies provided directly from a substation, protective equipment shall be installed within the substation.					
Note <sup>2</sup> The use of a pole mounted circuit breaker is not permitted to be used as a supply protection device for underground lines forming consumer's mains					

A3

### 7.5.4 Termination at a Distributor's Pole

#### 7.5.4.1 Work Practices

Termination of consumer's mains on a Distributor's pole shall be carried out in accordance with this clause, Clause 5.1 (Safety) and Clause 7.8 (Equipment other than Consumer's Mains on a Distributor's Pole) and all applicable industry requirements. These include but are not limited to the following:

- No Go Zone guidelines and framework
- Electricity Safety Act and Regulations
- Occupational Health and Safety Regulations

Except for reinstated poles, eg, staked, any pole marked with a large 'X' cut into or marked on the surface has a limited life and shall therefore be considered unsafe to climb or support a ladder.

#### 7.5.4.2 Responsibilities

The customer shall be responsible for the installation of their consumer's mains cables and equipment to a height of 4 metres above ground level. The relevant Distributor shall be responsible to perform any works above 4m.

Refer to the relevant Distributor for the maximum size and maximum number of conductors able to be terminated

A3

The customer/person or body responsible for the equipment shall be responsible for the installation, maintenance and liability associated with their equipment. This shall include the removal and/or relocation of the equipment if it impedes use of the pole by the Distributor, and the removal and re-installation of their equipment upon pole maintenance, relocation or replacement.

### 7.5.4.3 Installation

The use of a Distributor's pole for the installation of consumer's mains and its associated service protection device and consumer's terminals shall be in accordance with these Rules. Equipment other than consumer's mains shall be installed in accordance with the Code of Practice for Shared Use of Poles and the agreement with the relevant Distributor made under Clause 7.8 (Equipment other than Consumer's Mains on a Distributor's Pole).

Unless otherwise agreed with the relevant Distributor all electrical installation equipment shall be located in a position such that the equipment:

- Is least liable to mechanical damage;
- Is on the side of the pole least affected by vehicular traffic;
- Does not obscure a Distributor's pole identification disk, mark or number;
- Maintains integrity and be appropriately spaced from network earthing conductors; and
- Does not interfere with safe access to other equipment located upon the pole.

Unless otherwise agreed with the relevant Distributor consumer's terminals installed on poles shall be located at 4m above ground level.

### 7.5.4.4 Concrete Pole Attachments

Where consumer's mains and equipment are installed on a concrete pole carrying high voltage conductors, additional insulation shall be required between the concrete pole and the termination equipment.

Concrete and steel poles shall not be drilled under any circumstances as ingress of moisture can lead to failure of the pole.

Fixing of cables and equipment to concrete poles shall be effected by banding with suitable stainless steel bands and be so arranged that the band will not directly compress on cable sheaths, but will securely attach cables and equipment to the pole.

### 7.5.4.5 Underground Mains and Equipment Terminations

In addition to Clause 7.5.4.3 (Installation), Clause 7.5.4.4. (Concrete pole Attachments) and where permitted under Clause 7.8 (Equipment other than Consumer's Mains on a Distributor's Pole), underground consumer's cables and conductors terminated on a Distributor's pole shall be arranged in accordance with Figure 7.5-D and:

- installed to allow flexibility at the pole base and allow for pole replacement;
- provided with additional mechanical protection covers from 300mm below ground level to a point at a minimum of 2.4 m above ground level;
- enclosed in non-metallic rigid conduit where the size is less than 70mm<sup>2</sup>;
- terminated at 4 m above ground level;
- terminated into consumer's terminals enclosed within a FOLCB, FSD or Pole Mounted Circuit Breaker in accordance with the Regulations if the cables are consumer's mains; and
- terminated in the customer's switchboard if this is applicable.



A2

- terminated in the customer's switchboard in a weatherproof enclosure (Minimum IP33). In addition to Clause 7.5.4.3 (Installation), as the customer's switchboard is located on public land and to avoid unauthorised operation that may impair safety and the electrical installation, where the customer's switchboard is to be installed on a distribution pole, it shall be located between 3.0 and 4.0 metres from finished ground level and away from structures where persons can stand.

A3

A2

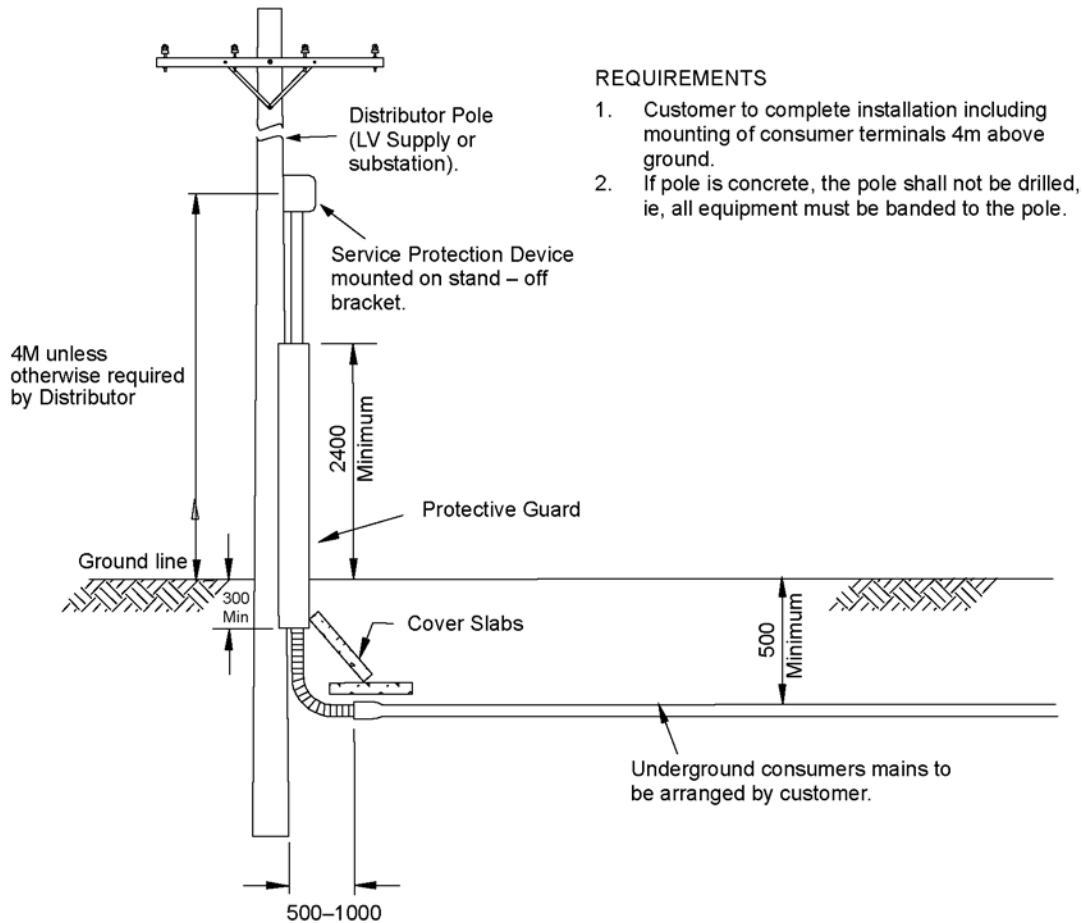

**Figure 7.5-D Typical Underground Consumer's Mains Termination on a Distributor's Pole**

#### 7.5.4.6

#### Private Aerial Line Termination

The Electricity Safety Act and Regulations require a circuit breaker to be fitted at the origin of any installed, altered, repaired or maintained private aerial line. These Rules require that unless otherwise agreed by the relevant Distributor, the circuit breaker complies with clause 6.8.5.2 (Pole Mounted Circuit Breakers) and be fitted in accordance with the Electricity Safety (General) Regulations and consumer's terminals for a private aerial line and as shown in Figure 7.5-E; and

A3

(a) Where the line is supplied from a Distributor's pole the customer shall:

- Install at 4 m from ground a circuit breaker that can be operated from the ground;
- Install a Supply Protection Assembly at 4m from the ground;
- Supply the private aerial line cable terminator to attach the line to the pole;
- Supply sufficient cable to be attached to the top of the pole and extend down to the circuit breaker; and

- Supply sufficient PVC rigid conduit and equipment to attach the conduit to the pole. The conduit shall be installed for the enclosure of the line from the attachment to the circuit breaker and be suitable to be installed in direct sunlight.
- (b) Where the line is supplied from a Distributor’s pole, other than a pole type substation, the customer shall:
  - Install a Supply Protection Assembly at 4 m from the ground;
  - Install at 4 m from ground a circuit breaker that can be operated from the ground; and
  - Provide a  $\geq 40$  mm PVC conduit attached to the pole that is suitable to be installed in direct sunlight to enclose the service line from the point of attachment to the circuit breaker.

A3

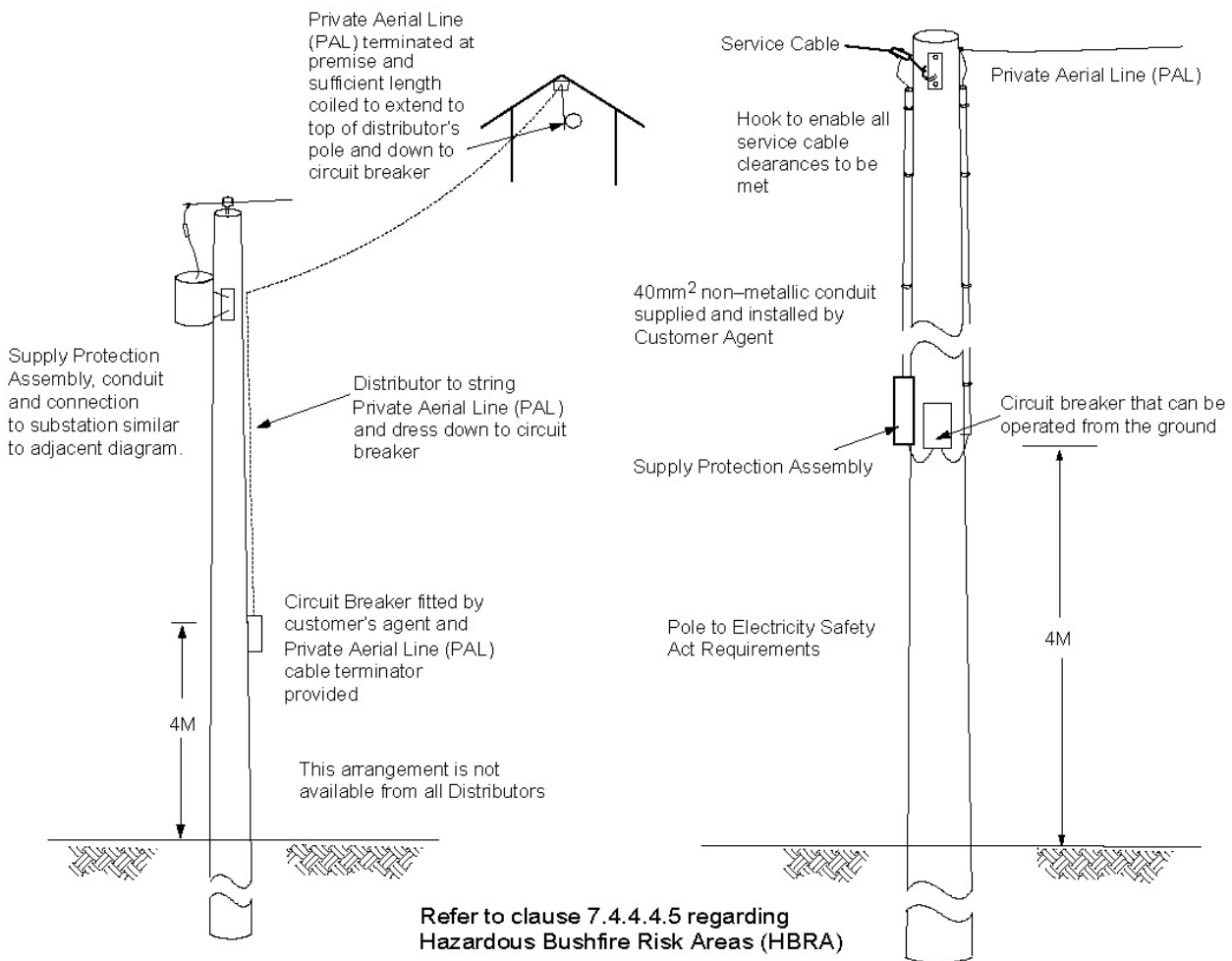
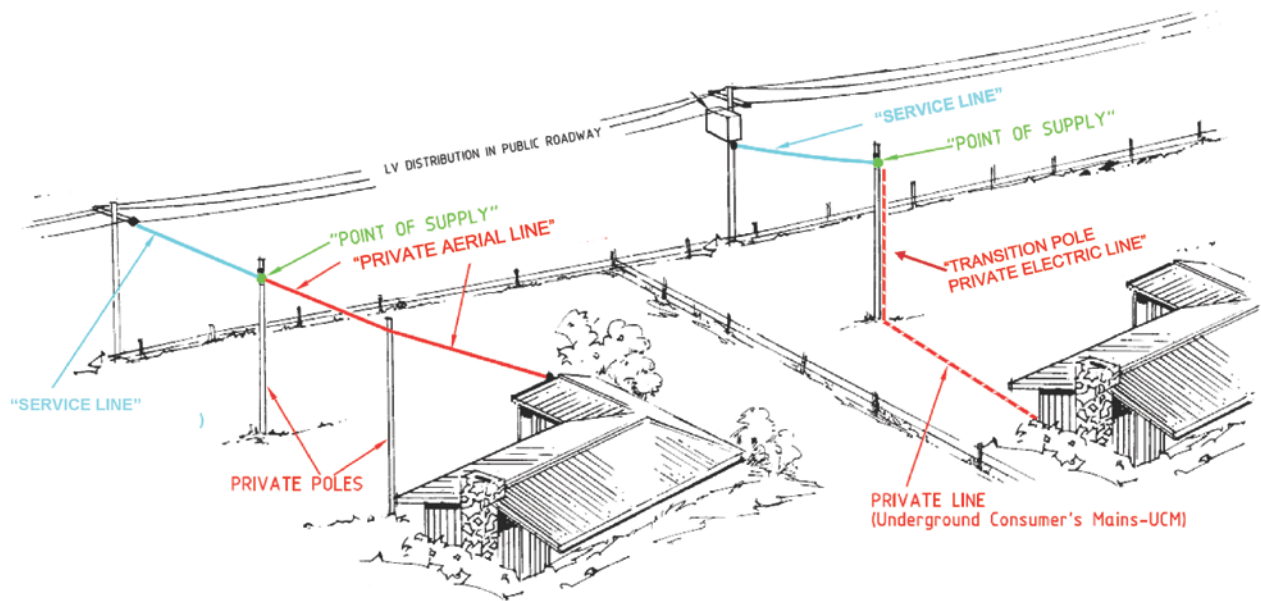

Figure 7.5-E Typical PAL Arrangements

FAQ 016

A3



**Figure 7.5-F Examples of Typical Private Aerial Lines & Underground Lines with Private and Transition Poles**

## 7.6

### Builder's Supply in a Permanent Position

The Electricity Safety Act and Regulations regulate the construction of electrical installations and includes specific standards for construction and demolition sites.

Where an electricity supply is required to a property for constructional purposes, supply may be given if it is available and when the permanent consumer's mains and metering facilities are installed in their permanent position.

The weatherproof meter enclosure shall be installed in accordance with:

- the Electricity Safety Act, Regulations, Wiring Rules and these Rules;
- the manufacturer's installation instructions; and
- be securely and rigidly fixed in its permanent position installed in a manner to prevent excessive vibration or movement.

To limit additional costs, the electrical installation should be constructed in a manner to avoid the necessity for further Distributor visits, eg, be connected to permanent consumer's mains and include provision for the permanent metering equipment.

For group metering, a main switchboard shall be installed with the Supply Capacity Control Device/s (SCCD) for the allowable load for the installation. Refer to clause 6.7.2. Where a portion of a group metering / main switchboard is to be used for a builders supply, that portion of the electrical installation shall not be arranged as an occupancy installation. It shall be arranged as a Builders supply. A CoES and EWR shall be provided stating the installation is a "Builders supply" (not occupancy number) and at the completion of construction another COES and EWR will be required prior to permanent connection of the occupancy.

Typical arrangements are shown in Figure 7.6-A.

A2

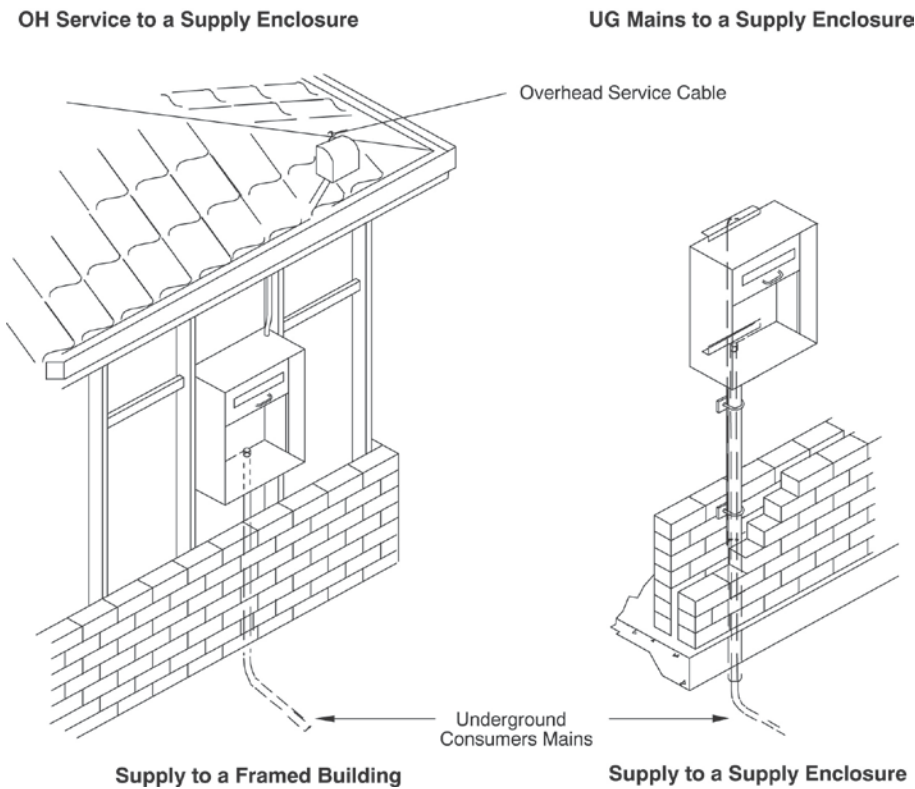

**Figure 7.6-A Typical Arrangements**

**7.7 Builder’s Supply Pole in a Non-Permanent Position**

**7.7.1 Provision**

The relevant Distributor may, subject to supply being available and the payment of relevant charges, provide a supply to an electrical installation for a limited period for builder supplies.

The customer should ascertain that the supply can be made available, and the conditions which would apply before commencement of any works.

**7.7.2 Supply Poles**

The electrical installation shall be constructed in accordance with the servicing and metering arrangements as detailed in these Rules, and adequate protection shall be installed to prevent damage to the Distributor’s servicing and metering equipment.

Metering arrangements for limited period supplies, including metering arrangements for builder’s supply poles are detailed in Section 8 (LV Metering).

Where a supply is provided for a limited period for construction purposes, it shall be disconnected at the time of connection of any permanent supply to the site unless prior arrangements have been made by the customer for the retention of the supply and any relevant additional charges paid.

ESV has produced guidelines for builder’s supply poles to assist in the provision of electricity supplies to construction sites. A copy of these guidelines can be obtained from the ESV website.

**Underground Consumer’s Mains Supplying Switch Board on Construction and Demolition Sites**

The *Electricity Safety (General) Regulations* require that any underground consumer’s mains installed on a construction site that exit the ground to enter into a switchboard/metering enclosure must:

A3

A3

be double insulated up to the first protective device within the switchboard or metering enclosure; and

- be enclosed in compliant heavy duty non-metallic conduit from the point they exit the ground up to the point at which they enter the switchboard/metering enclosure; and
- be provided with additional mechanical protection from the point they exit the ground up to within 100mm of the switchboard/metering enclosure that is constructed of:
  - a galvanized steel tube with a wall thickness of at least 3.2mm; or
  - a 1.6mm thick or grater, sheet steel cover with an unsupported width not exceeding 100 mm; or
  - an enclosure or wiring system that meets the mechanical protection classification of WSX3 specified in Appendix F of AS/NZS 3013.

## 7.8 Equipment other than Consumer's Mains on a Distributor's Pole

Equipment other than consumer's mains detailed in Clauses 7.5.4 (Termination at a Distributor's Pole) shall not be installed upon a Distributor's Pole unless permitted by a written agreement with the relevant Distributor. Where an agreement exists the access to and installation and maintenance of the equipment shall be in accordance with the agreement and these Rules.

Typical equipment that is subject to an agreement with the relevant Distributor and compliance with the Shared Use of Poles Code includes:

- Electrical installations attached to poles for broadband transmissions and mobile library supplies; and
- Parts of electrical installations containing other than consumer's terminals and service protection devices, eg; circuit breakers, residual current devices or other control gear and cabling that supply electrical installations such as bus shelters, telecommunications equipment, public lighting, sprinkler systems etc; and
- Lights, Traffic Signals, Antennas, telecommunication/broadband cabling, signs, banners, decorations, etc.

Application for installation of equipment on a Distributor's pole should be made in accordance with clause 4.4 (Application for Supply Availability) at the earliest opportunity after a decision to proceed is made.

In all cases, where equipment other than network assets are located upon a Distributor's pole, the customer/person or body responsible for the equipment shall be responsible for the installation, maintenance and liability associated with their equipment. This shall include the removal and/or relocation of the equipment if it impedes use of the pole by the Distributor, and the removal and re-instatement of their equipment upon pole maintenance, relocation or replacement.

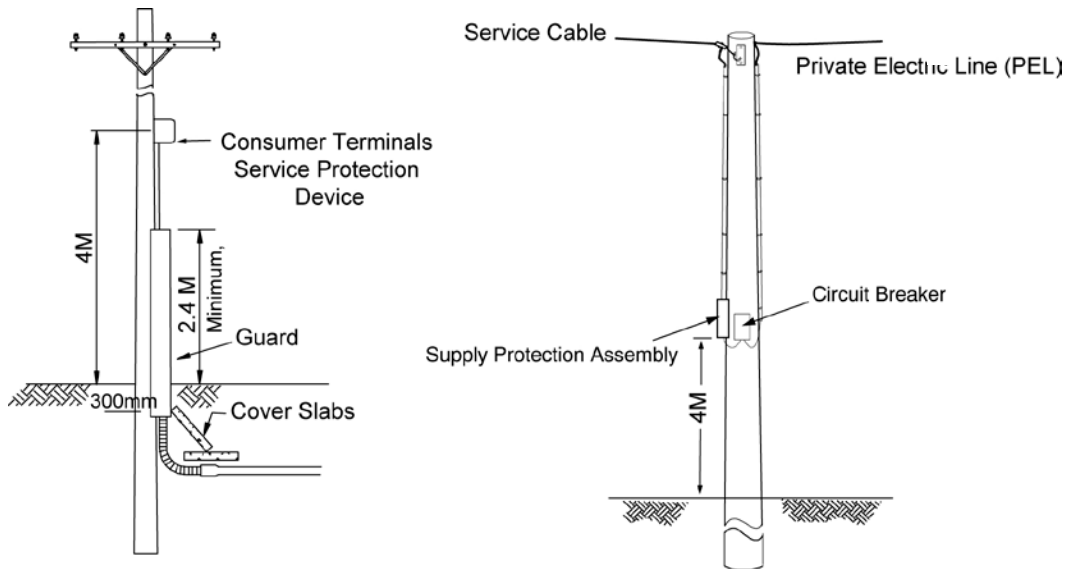

**Figure 7.8-A Maximum Equipment on a Distributor’s Pole without an Agreement**

**7.9 Electrical Installations on Public Land**

**7.9.1 General**

Electrical installations supplied from and contained within public land as defined in Clause 5.7 (Private Electric Lines on Public Land) shall comply with this clause and the other requirements of these Rules. The relevant Distributor shall be contacted prior to consolidating any proposal to install an electrical installation on public land.

**7.9.2 Labelling**

Equipment forming electrical installations which are located on public land should be labelled where there is a risk of incorrect identification between an electrical installation’s equipment and a Distributors’ network assets.

Equipment required to be labelled includes public lighting columns and schemes owned and operated by bodies such as VicRoads and Municipal Councils, and other equipment such as pillars and cubicles where there is a risk of incorrect identification.

Labels should include the responsible organisation logo and their contact telephone number and be installed in accordance with clause 5.4 (Labelling).

**7.9.3 Meter Locations**

Meter locations in Public land shall be located as required by Clause 8.6.3 (Public Land) and 8.6.4 (Unsuitable Meter Locations)

**7.10 Multiple Occupancy Buildings and Subdivisions (Supply Arrangements)**

**7.10.1 General**

This clause applies to the supply and distribution arrangements for multiple occupancy buildings and subdivisions. Refer to Clauses

- 4.4.2 Multiple Occupancy Buildings and Subdivisions (Application)
- 5.8 Multiple Occupancy Buildings and Subdivisions (General) and
- 8.10.2 Multiple Occupancy Buildings and Subdivisions (Metering Arrangements) additional requirements.

A3

## 7.10.2 Plan

A2 | A plan shall be submitted to the relevant Distributor in accordance with this clause and Clause 8.10.2 for approval. The plan shall be submitted prior to finalisation of the electricity supply, distribution and metering arrangements associated with the particular multiple occupancy building or subdivision.

Failure to submit a plan in accordance with these Rules, prior to construction of the electrical installation, may result in unnecessary financial expense and substantial delay in order to rectify any discrepancies with these Rules and connect the electricity supply.

The plan shall:

- Show or state the location of the metered and un-metered consumer's mains, sub-mains and metering points in relation to the common property or common area;
- Include a schematic diagram representing the proposed electricity distribution arrangement to the occupancies or lots contained within the property; and
- The meter locations and isolation arrangements as detailed in Clause 8.10.2 Multiple Occupancy Buildings and Subdivisions (Metering Arrangements)

## 7.10.3 Subdivisions Incorporating Common Property

7.10.3.1 | The electricity to all of the lots shown on a plan of subdivision shall be supplied from a common distribution point which is connected to a single point of supply where:

- A2 |
- (a) the plan of subdivision incorporates common property; and
  - (b) the lots shown on the plan of subdivision are affected by any Owners Corporation for the common property for any common property shown on the plan of subdivision

7.10.3.2 | Notwithstanding clause 7.10.3.1, provided there are no increased safety risks, (as per but not limited to the notes in clause 6.2.2.2) lots shown on the plan of subdivision incorporating common property that are affected by any Owners Corporation and abut a public road reserve but do not abut the common property may be provided with a separate point of supply.

7.10.3.3 | A Distributor may consider a request to provide more than one point of supply under the relevant provisions of clause 6.2.2.2 (Provision)

7.10.3.4 | The consumer's mains, metering equipment, general distribution switchboards and the individual consumer's sub-mains, installed for the purpose of supplying electricity to each of the lots, shall be placed within the common property. For the purpose of supplying electricity to each of the lots intended to be supplied from a single point, each lot shall abut the common property. Additional information related to the arrangement wiring and equipment is provided in clauses;

- 6.2 Point of Supply,
- 6.3 Consumer's Terminals,
- 8.10.2 Multiple Occupancy Buildings and Subdivisions (Metering Arrangements).

NOTE: Further information is provided in Figures 7.10-D to 7.10-I.

## 7.10.4 Subdivisions Not Incorporating Common Property

7.10.4.1 | Lots shown on a plan of subdivision, which does not incorporate common property, shall be provided with a point of supply for each lot. For the purpose of establishing a single point of supply for each of the lots, all of the lots shown on the plan of subdivision shall abut a public road reserve.

A2 | Further information is provided in Figures 7.10-A to 7.10-C.

**7.10.4.2** The point of supply, consumer's terminals and metering equipment shall be arranged in accordance with clauses;

- 6.2 Point of Supply,
- 6.3 Consumer's Terminals and
- 8.10.1 Single Occupancy.

## **7.10.5 Multiple Occupancy Buildings**

**7.10.5.1** Multiple occupancy buildings will be provided with a single point of supply. A Distributor may consider a request to provide more than one point of supply under the relevant provisions of clause 6.2.2.2 (Provision).

**7.10.5.2** The consumer's mains, metering equipment, general distribution switchboards and the consumer's sub-mains installed for the purpose of supplying electricity to each of the occupancies, shall be placed within the common area. Additional information related to the aforementioned wiring and equipment is provided in clauses;

- 6.2 Point of Supply,
- 6.3 Consumer's Terminals,
- 8.10.2 Multiple Occupancy Buildings and Subdivisions (Metering Arrangements).

## **7.10.6 Possible Subdivision of Buildings or Land**

The following information is intended to assist persons wishing to exercise an option to subdivide their property in the future. Where the subdivision of buildings or land is a possibility, it will be necessary for the property owner or developer to submit a draft plan of subdivision to the Distributor. The draft plan of subdivision is essential for the purpose of establishing an appropriate electricity supply arrangement and avoiding unnecessary future expense.

## **7.10.7 Supply Arrangement Diagrams**

Where there is a risk of incorrect identification of the occupancies supply arrangements, including segregation between the electrical installations, occupancies un-metered wiring, switchboards and metering, supply arrangement diagrams shall be installed and maintained in accordance with the relevant provisions of clause 6.4 (Supply Arrangement Diagrams).

## **7.10.8 Labelling**

In addition to Australian Standards, labels that comply with Clause 5.4 (Labelling) shall remain clearly visible after installation of all equipment and comply with the following:

- All switches installed on the line side of Distributor grouped metering equipment shall be labelled "UN-METERED SWITCH" and
- Occupancy Disconnection Device (ODD) controlling CT metering shall be labelled "Occupancy Disconnection Device, TO BE OPERATED BY AUTHORISED PERSONS ONLY" and capable of being secured in the OFF position in accordance with Clause 8.4.5.3 (Sealing and Locking);
- Each set of consumer's terminals, un-metered switchboards, meter panels, occupancy meter/s, ODDs and occupancy switchboards to indicate the occupancies they control or are related to;
- Each occupancy entrance and distribution switchboard shall be identified to correspond with the supply address;
- Any ODD supplying safety services shall indicate the portion/s of the electrical installation it controls and be labelled in accordance with Clause 8.10.2.12 (Occupancy Disconnection Devices);



- Where the occupancy consists of a number of separate areas or street addresses, each of the occupancies shall be labelled or identified in a manner acceptable to the relevant Distributor.
- Examples of suitable labelling;

**Un-metered Occupancy Disconnection Device,**

**Do Not Switch Off in the Event of Fire, Mechanical Services, Lift, Fire Pump,**

**To Be Operated By Authorised Persons Only**

**7.10.9 Un-metered Connections & Equipment**

**FAQ 014**

Enclosures and sections of enclosures such as connection facilities, switchboards and metering facilities containing un-metered connections and equipment shall be provided with sealing and locking facilities in accordance with Clause 5.6 (Sealing and Locking).

All locking facilities shall be permanent and fit for purpose.

A3 |

**7.10.10 Wiring Arrangements**

Wiring arrangements for multiple occupancy buildings and subdivisions are required to comply with the Electricity Safety Act and Regulations, and these Rules. The Act and Regulations requirements include but are not restricted to mean:

- Wiring for an individual lot to be contained within that lot, common area or common property;
- Alterations and Additions to existing installations to be made in accordance with the current Wiring Rules;
- Labels to be applied in accordance with the Electricity Safety Act and Regulations:

Note, For the purpose of obtaining consent to compliance to a proposed subdivision. The following shall apply to buildings connected to supply prior to the 2nd August, 1991. Where the supply arrangement to the lots within the subdivision has been established at a single point and the wiring supplying the lots is not located within common property, such an arrangement is acceptable provided the lots are affected by an Owners Corporation created by the subdivision and section 12.2 of the Subdivision Act 1988 applies.

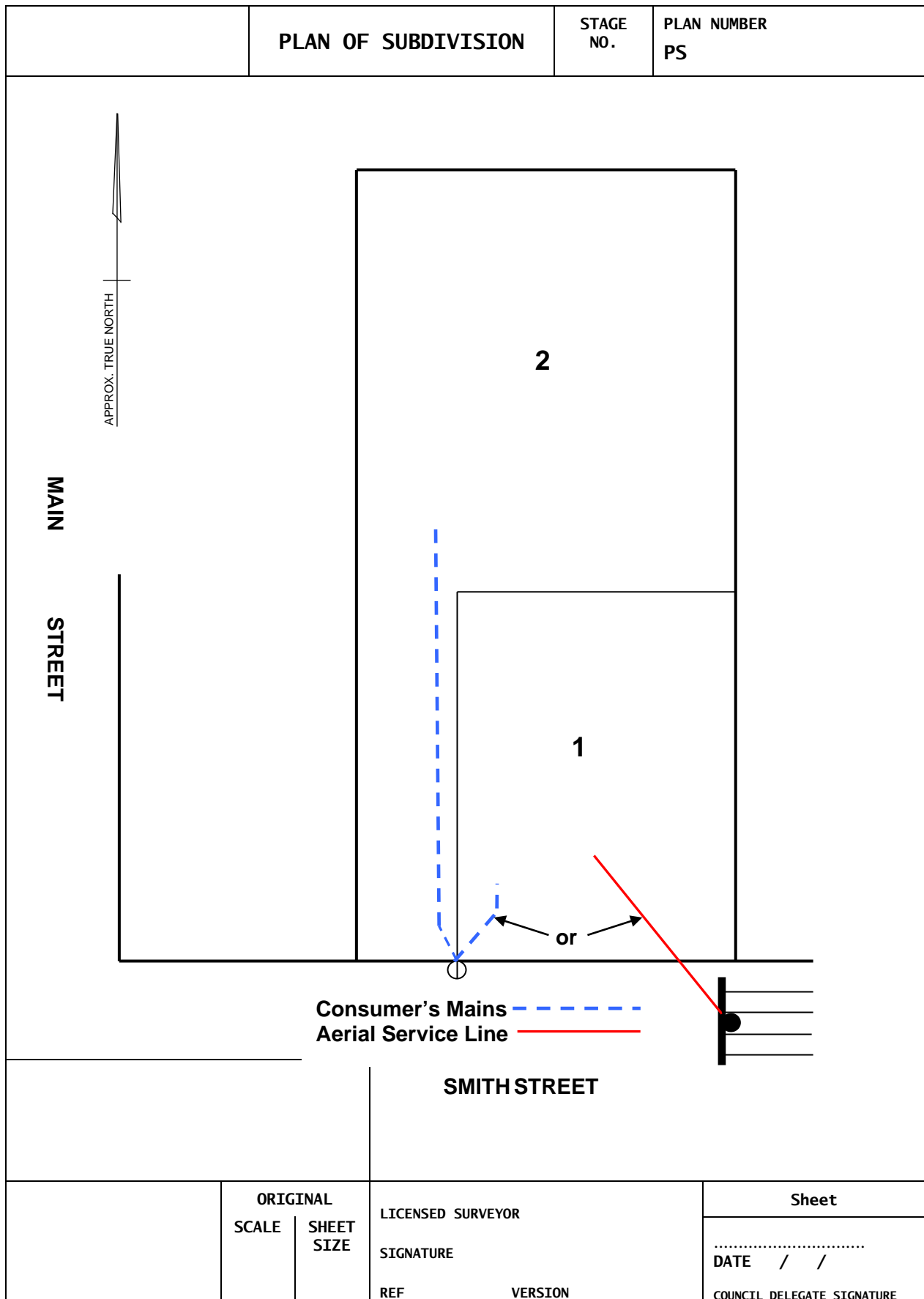

**Figure 7.10-A Example Supply Arrangements for a Subdivision Not Incorporating Common Property. Underground/Overhead Distribution**

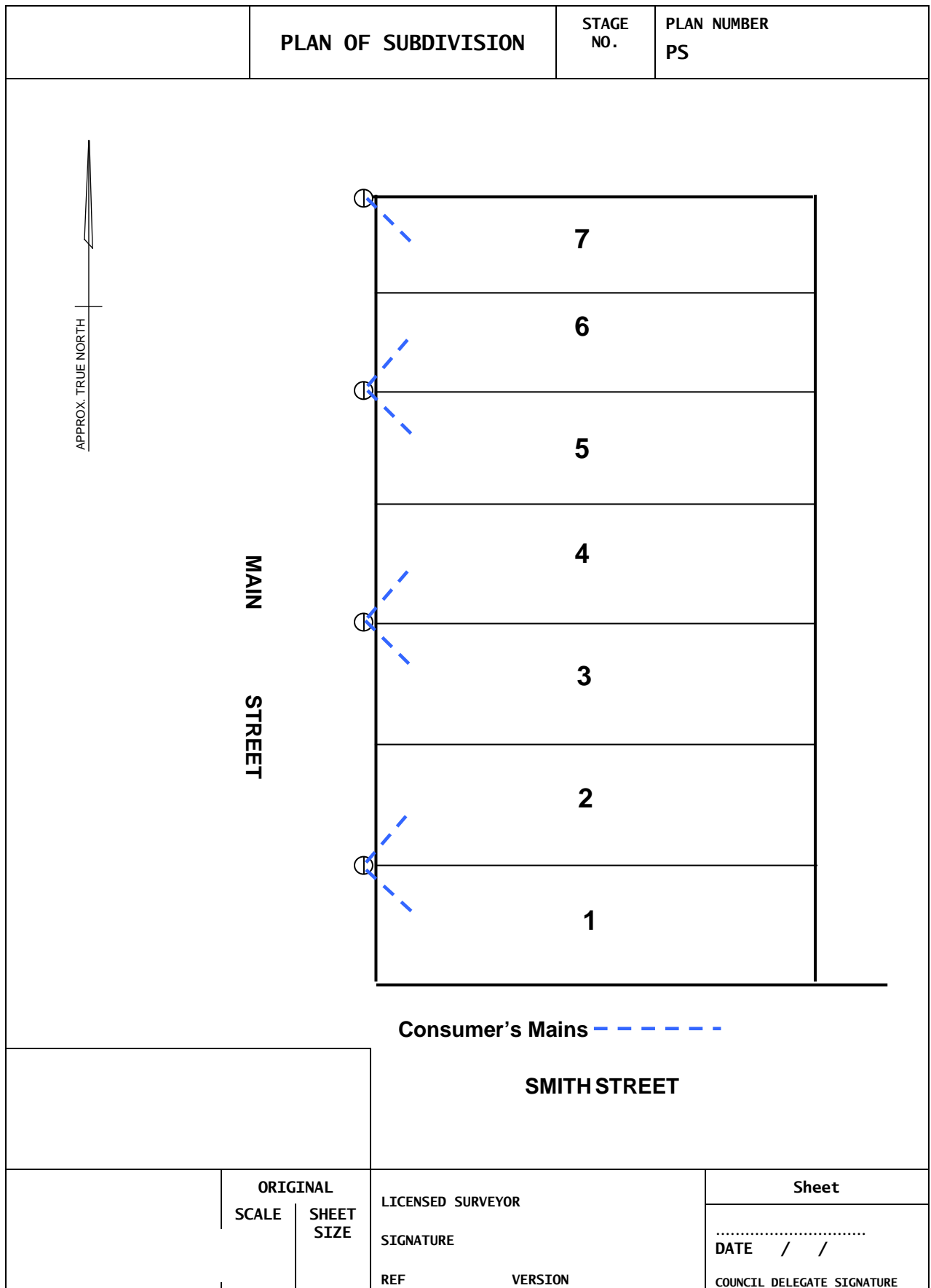

**Figure 7.10-B Example Supply Arrangements for a Subdivision  
Not Incorporating Common Property**

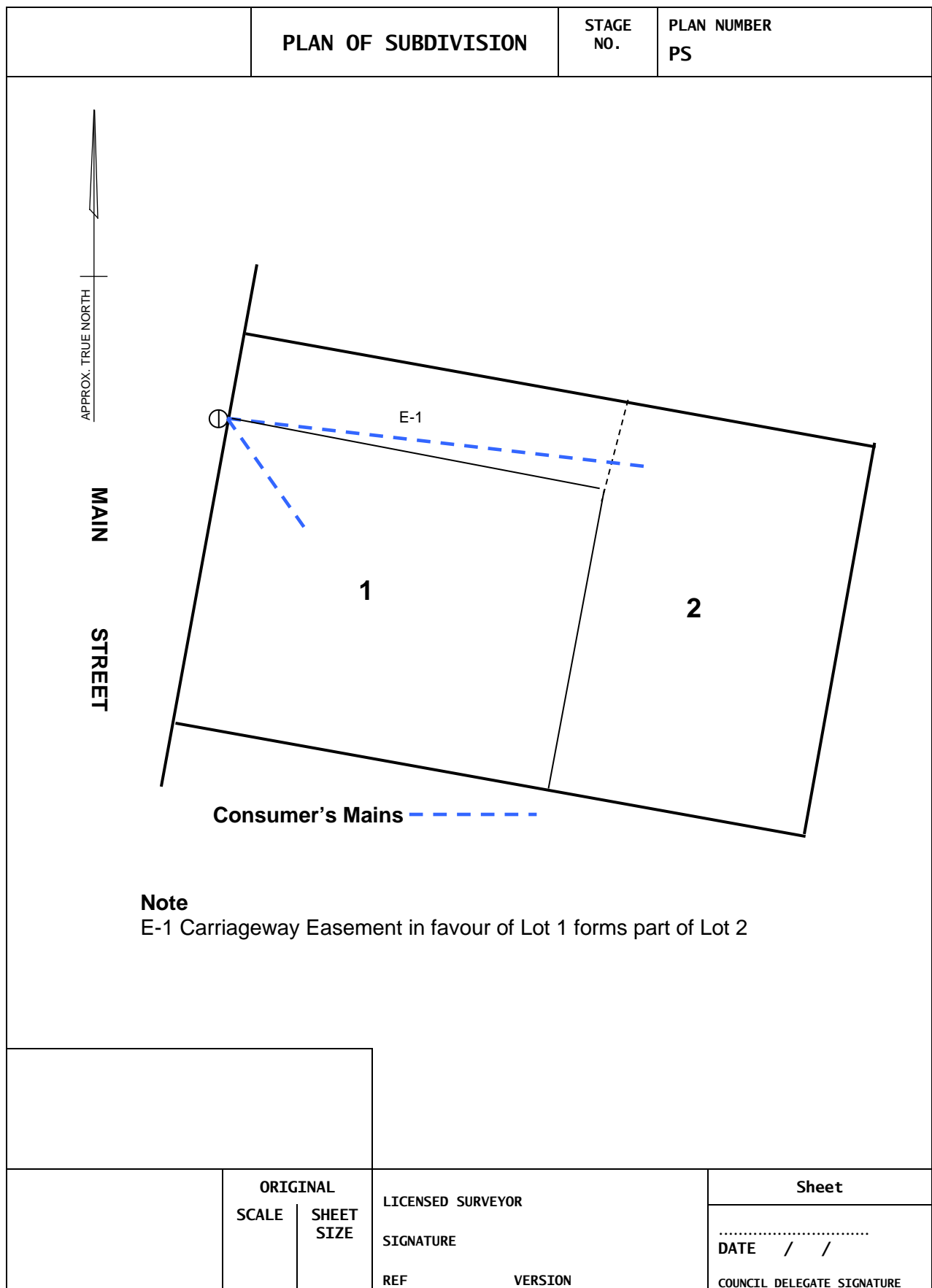

**Figure 7.10-C Example Supply Arrangements for a Subdivision  
Not Incorporating Common Property**

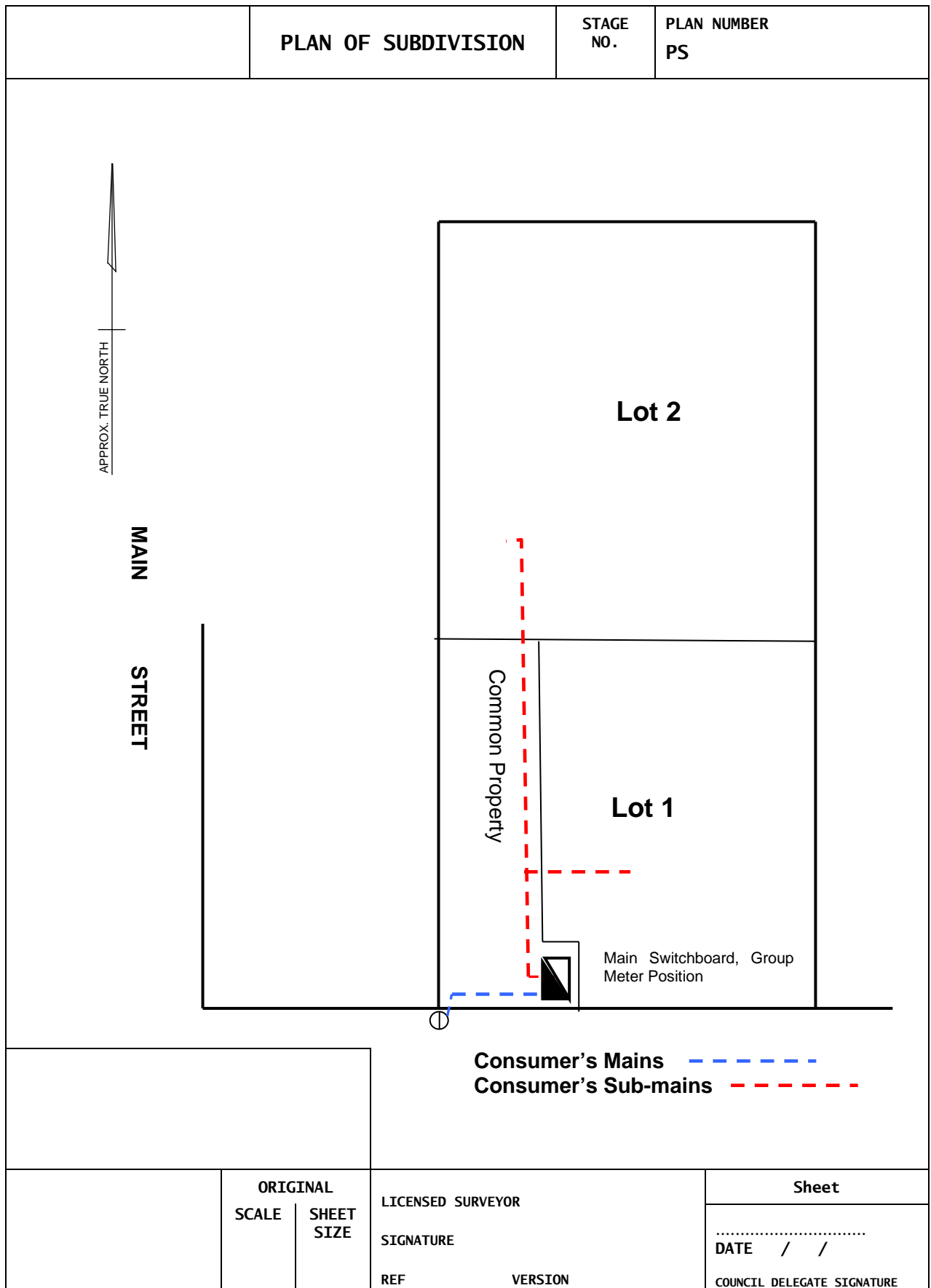

**Figure 7.10-D Example Supply Arrangements for a Subdivision Incorporating Common Property**

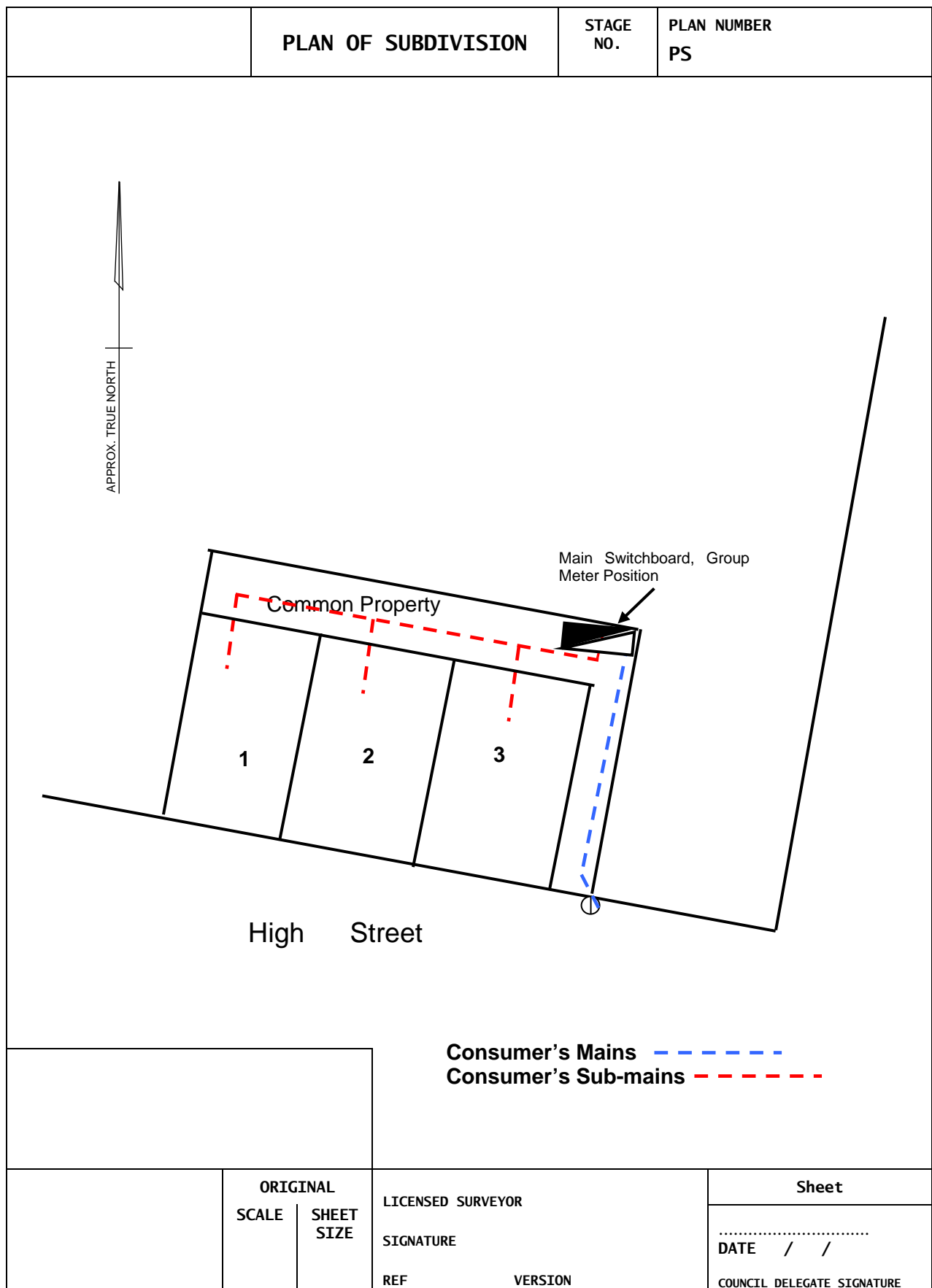

**Figure 7.10-E Example Supply Arrangements for a Subdivision Incorporating Common Property**

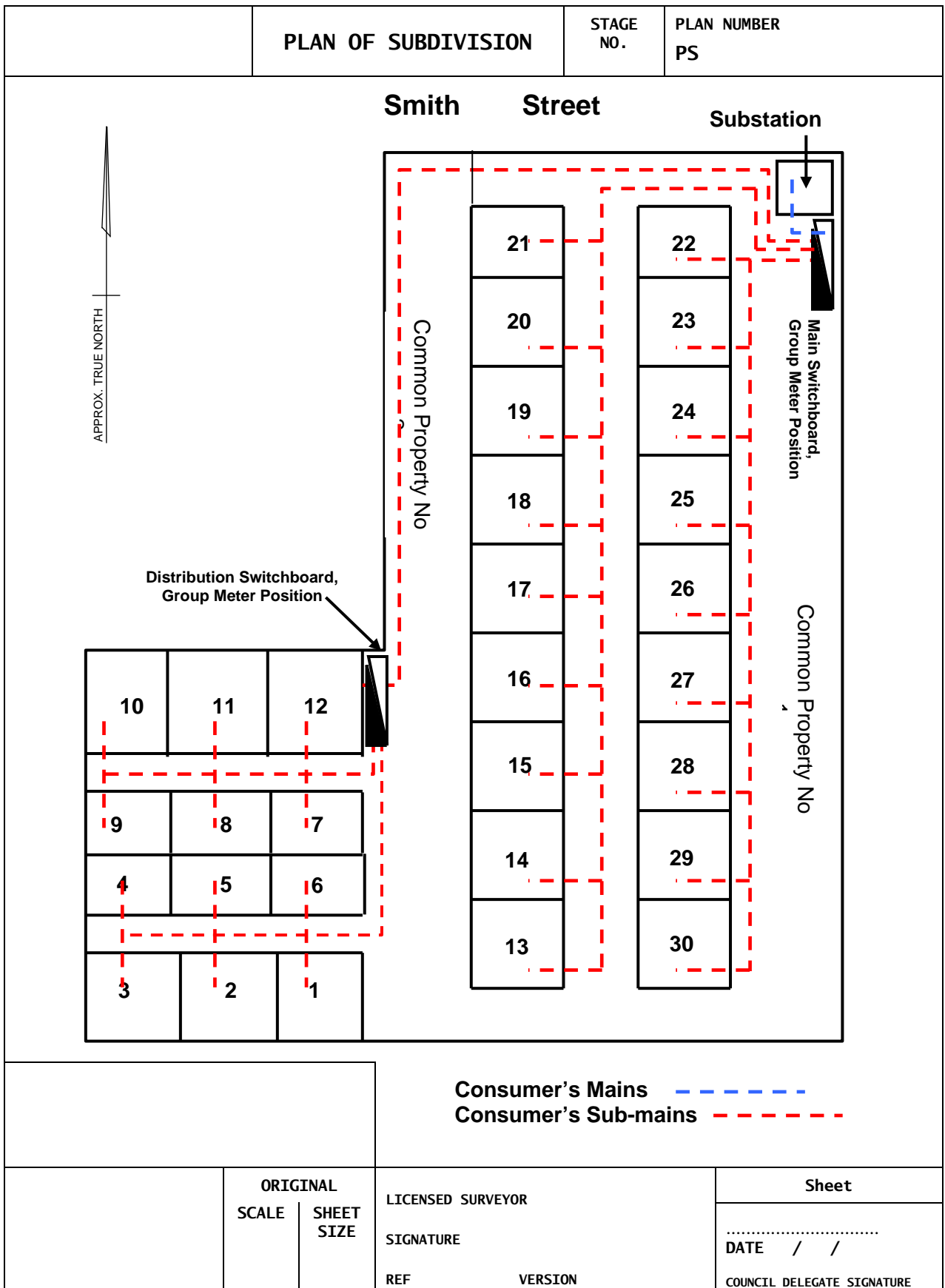

**7.10-F Example Supply Arrangements for a Subdivision Incorporating Common Property**

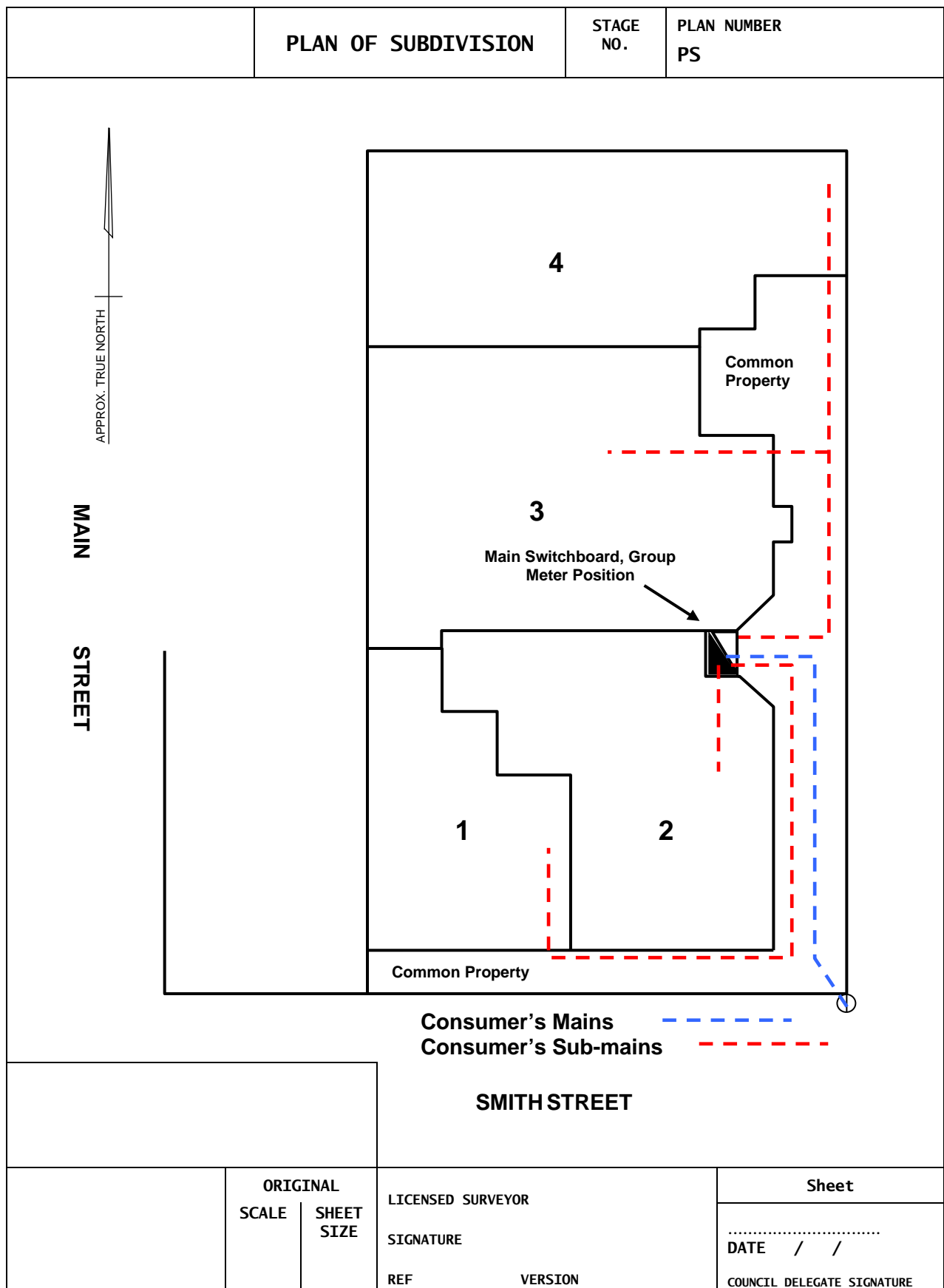

**7.10-G Example Supply Arrangements for a Subdivision  
Incorporating Common Property**



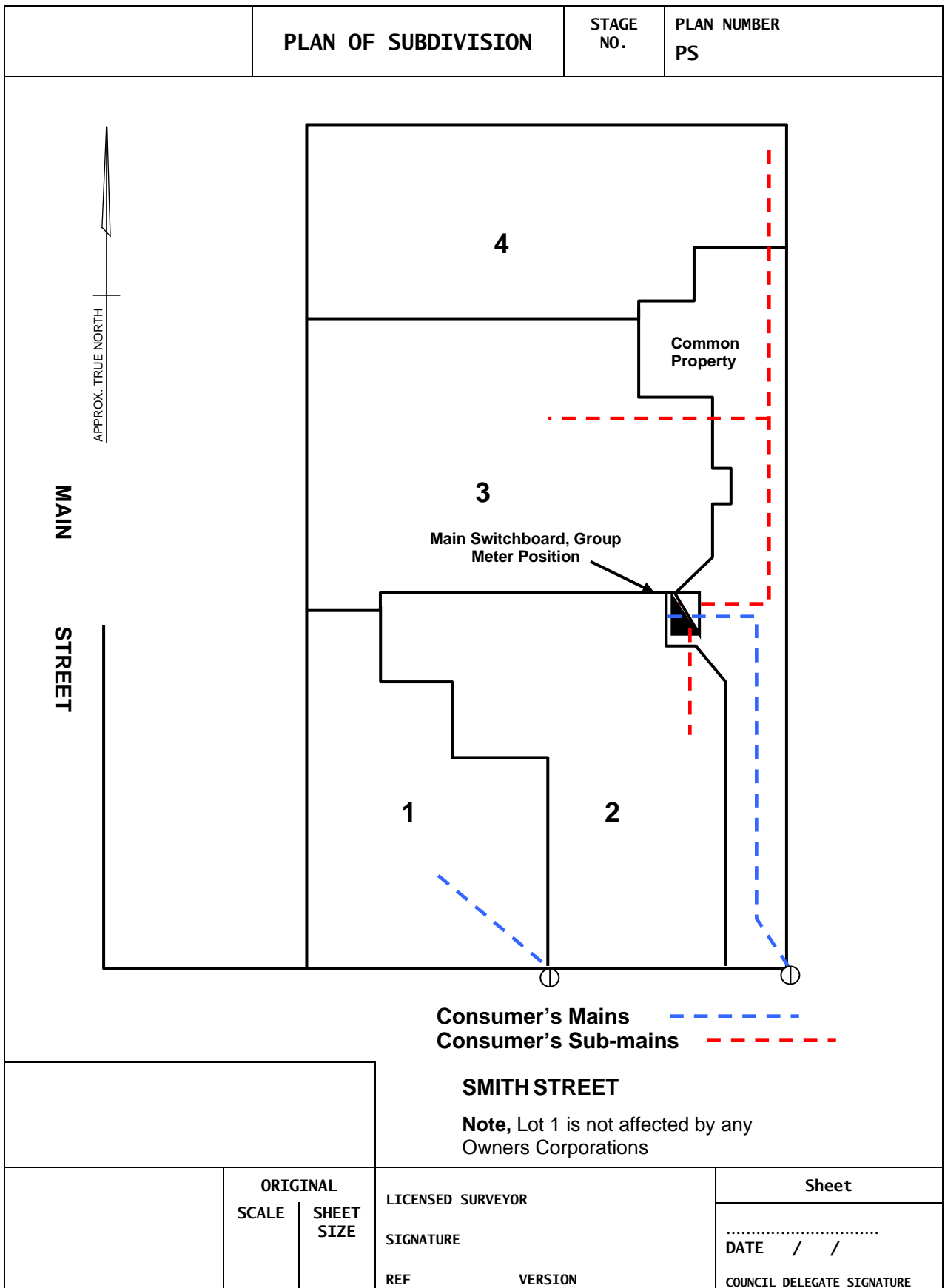

**7.10-H Example Supply Arrangements for a Subdivision Incorporating Common Property**

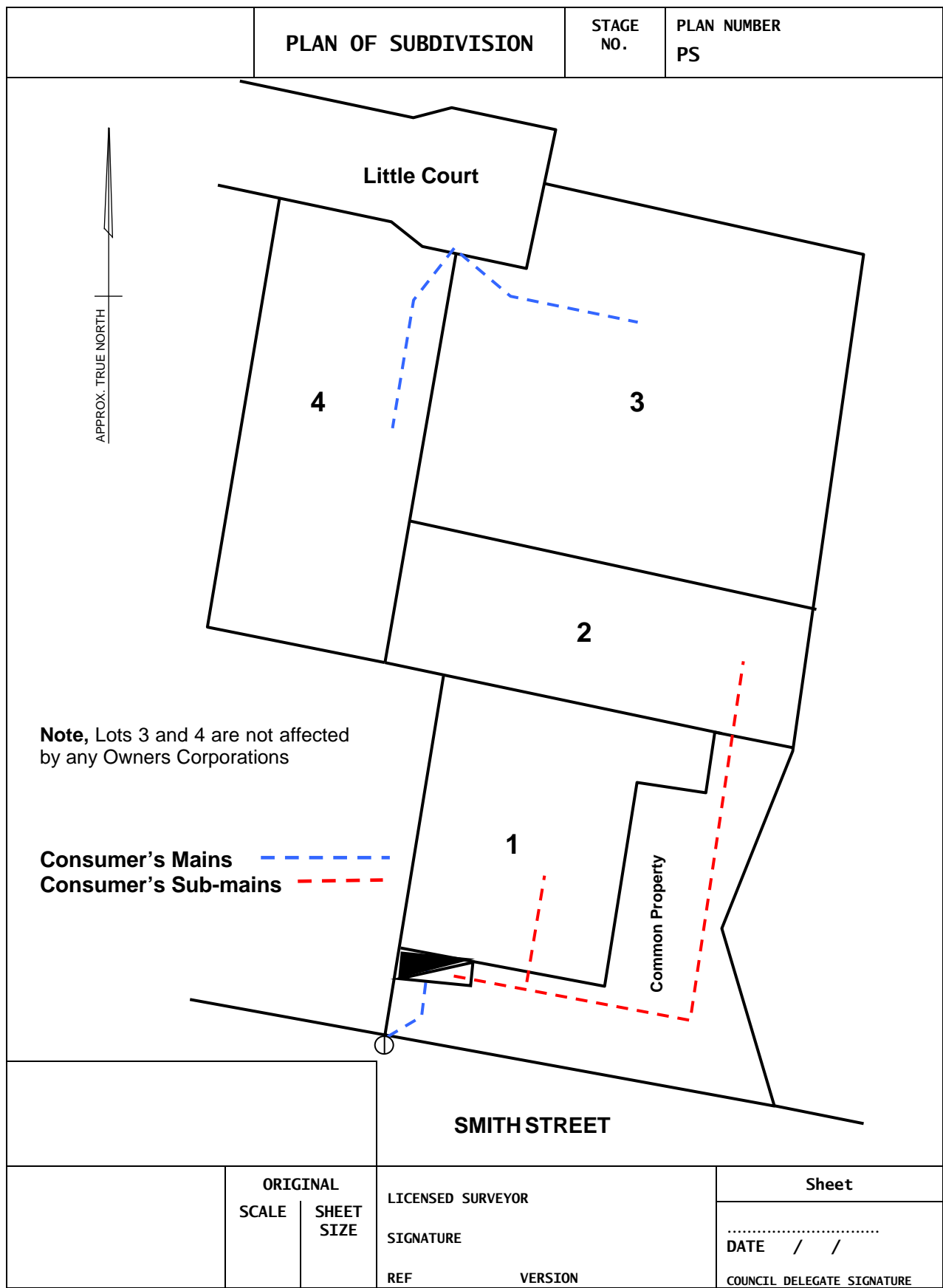

**7.10-I Example Supply Arrangements for a Subdivision Incorporating Common Property**

# Section 8

## Low Voltage Metering

<b>Section 8 – Contents</b>		<b>Page</b>
<b>8.1</b>	<b>Scope</b>	<b>8-6</b>
<b>8.2</b>	<b>Tariffs &amp; Metering Configurations</b>	<b>8-6</b>
<b>8.3</b>	<b>Metering Obligations</b>	<b>8-6</b>
<b>8.4</b>	<b>Metering Facilities</b>	<b>8-7</b>
8.4.1	General	8-7
8.4.2	Timber Panels & Boards	8-7
8.4.3	Meter Panels	8-8
8.4.3.1	Size	8-8
8.4.3.2	Installation	8-8
8.4.3.3	Materials	8-9
8.4.3.4	Wiring Holes	8-9
8.4.3.5	Fixing and Sealing	8-9
8.4.3.6	Labelling	8-9
8.4.3.7	Wiring	8-9
8.4.4	Metering Surrounds and Enclosures	8-10
8.4.4.1	General	8-10
8.4.4.2	Meter Surrounds	8-10
8.4.4.3	Meter Enclosures:	8-11
(a)	Type not exposed to Weather or Adverse Environment	8-11
(b)	Type exposed to Weather or Adverse Environment	8-11
8.4.4.4	Acceptance & Marking	8-12
8.4.5	Equipment	8-12
8.4.5.1	Acceptance	8-12
8.4.5.2	On Meter Panels or Within Enclosures	8-12
8.4.5.3	Sealing & Locking	8-13
<b>8.5</b>	<b>Access</b>	<b>8-13</b>
8.5.1	General	8-13
8.5.2	Locks	8-14
<b>8.6</b>	<b>Location</b>	<b>8-14</b>
8.6.1	General	8-14
8.6.2	Rooms	8-14
8.6.3	Public Land	8-14
8.6.4	Unsuitable Metering Locations	8-15
<b>8.7</b>	<b>Protection against Damage to and Interference with Metering Equipment</b>	<b>8-16</b>
<b>8.8</b>	<b>Metering Equipment - Limits of Operation</b>	<b>8-16</b>
8.8.1	Direct Connected Meter - Limits of Current Carrying Capacity	8-16
8.8.2	Meters - Temperature Limits of Specified Operating Range	8-16
<b>8.9</b>	<b>Direct Connected Metering</b>	<b>8-17</b>
8.9.1	Meter Panels	8-17
8.9.2	Meter Panel Heights and Clearances	8-17
Figure 8.9-A	Meter Panel Heights & Minimum Clearances	8-17

<b>Section 8 – Contents</b>		<b>Page</b>
8.9.3	Meter Wiring	8-18
8.9.3.1	General	8-18
8.9.3.2	Meter Panel Conductors	8-18
Table 8.9-1	Meter Panel Conductor Specifications and Limitations	8-19
8.9.3.3	Wiring Arrangements	8-19
8.9.3.4	Remote Meter Enclosure Earthing	8-19
Figure 8.9-B	Typical Arrangement of Earthing of Remote Metering Enclosure Without a Switchboard	8-20
8.9.4	Equipment	8-20
<b>8.10</b>	<b>Specific Situation Requirements</b>	<b>8-21</b>
8.10.1	Single Occupancy	8-21
8.10.1.1	Isolation	8-21
8.10.1.2	Meter Panels	8-21
Table 8.10-1	Single Occupancy Typical Meter Panel Sizes	8-21
8.10.1.3	Meter Location	8-21
8.10.1.3 (a)	Domestic	8-21
Figure 8.10-A	Individual Electrical Installations Acceptable Meter Locations	8-22
8.10.1.3 (b)	Commercial / Industrial Meter Locations	8-23
8.10.1.4	Labelling	8-23
8.10.1.5	Neutral Links	8-23
Figure 8.10-B	Small/Medium Individual Commercial/Industrial Installations Acceptable Meter Locations	8-24
Figure 8.10-C	Acceptable Meter Locations for Elevated Premises	8-25
Figure 8.10-D	Meter Enclosure Near Gas & Water Meters & L.P.G. Exchangeable Gas Cylinders for Domestic Installations	8-26
Figure 8.10-E	Meter Enclosure – Metal	8-27
Figure 8.10-F	Typical Meter Panel Metal Mounting Surround	8-28
Figure 8.10-G	Typical Arrangement for Limited Period Supply Pole	8-29
Figure 8.10-H	Typical Metering Details for One Customer Single Phase, With or Without Load Control, Panel Size 400 mm W x 380 mm H	8-30
Figure 8.10-I	Typical Metering Details for One Customer Multi Phase Panel Size 400 mm W x 380 mm H	8-31
8.10.2	Multiple Occupancy Buildings and Subdivisions (Metering Arrangements)	8-32
8.10.2.1	Plan	8-32
8.10.2.3	Subdivisions Incorporating Common Property	8-32
8.10.2.4	Subdivisions Not Incorporating Common Property	8-32
8.10.2.7	Multiple Occupancy Buildings	8-32
8.10.2.8	Possible Subdivision of Buildings or Land	8-32
8.10.2.9	Grouping of Meters	8-32
Table 8.10-2	Multiple Occupancy – Typical Meter Panel Sizes	8-33
8.10.2.10	Labelling	8-33

<b>Section 8 – Contents</b>		<b>Page</b>
8.10.2.11	Meter Panel Isolation	8-33
8.10.2.12	Occupancy Disconnection Devices (ODD)	8-33
Figure 8.10-J	Typical Metering Details for Two Customers, Single Phase, With or Without Load Control, Panel Size 400 mm W x 380 mm H	8-34
Figure 8.10-K	Typical Metering Details for Two Customers, 1 – Multiphase Meter, 1 – Single Phase Meter, Panel Size 400 mm W x 380 mm H	8-35
Figure 8.10-L	Typical Metering Details for Two Customers, 1 – Multiphase Meter, 1 – Single Phase Meter with load control, Panel Size 400 mm W x 380 mm H	8-36
A2   Figure 8.10-M-(a)	Typical Metering Details for Three Customers Single Phase, With or Without Load Control	8-37
Figure 8.10-M-(b)	Typical Metering Details for Four Customers Single Phase, With or Without Load Control and With or Without SCCD	8-37-A
Figure 8.10-N	Typical Meter Details – 5 Customers all Single Phase. Panel Size 600 mm W x 600 mm H	8-38
Figure 8.10-O	Typical Meter Panel Drilling Template for Figure 8.10-N	8-39
Figure 8.10-P	Typical Metering Arrangement for Two Customers 2 – Multiphase Panel Size 400 mm W x 590 mm H Complete with Supply Protection Devices	8-40
Figure 8.10-Q	Typical Meter Panel Drilling Template for Figure 8.10-P	8-41
Figure 8.10-R	Typical Metering Arrangement for Three Customers 3 – Multiphase Panel Size 600 mm W x 600 mm H Complete with Supply Protection Devices	8-42
Figure 8.10-S	Typical Meter Panel Drilling Template for Figure 8.10-R	8-43
Figure 8.10-T	Typical Wiring Diagram for Separately Metered Occupancies Including CT Metering for Proprietor	8-44
Figure 8.10-U	Typical Arrangements of Main Switchboard and Metering for 12 Occupancies	8-45
Figure 8.10-V	Typical Meter and Switchboard Arrangements for 9 Customers all Single Phase. Panel Size 600 mm X 900mm	8-46
Figure 8.10-W	Single Phase Meter Drilling Templates	8-47
Figure 8.10-X	Three Phase Meter Drilling Templates	8-49
8.10.3	Embedded Networks	8-51
Figure 8.10-Y	Illustrates an Embedded Network in an Apartment Block.	8-51
8.10.3.1	General	8-51
Figure 8.10-Z	Single Installation - Embedded Network (Downstream of Parent Meter)	8-52
A2   Figure 8.10-AA	Single Installation - Multiple Occupancy including an Embedded Network	8-53
8.10.3.2	Facilities	8-53
8.10.3.3	National Electricity Market (NEM) Metering	8-53
8.10.3.4	Embedded Network Operator Customer (ENOC) Metering	8-53
8.10.3.5	Conversion to an Embedded Network	8-54
8.10.3.6	Embedded Network Planning	8-54

A2

<b>Section 8 – Contents</b>		<b>Page</b>
8.10.3.7	Embedded Network Operational Requirements	8-55
<b>8.11</b>	<b>LV Current Transformer Metering</b>	<b>8-56</b>
8.11.1	General	8-56
8.11.2	Meter Panel	8-56
8.11.2.1	Panel	8-56
8.11.2.2	Location and Access	8-56
8.11.2.3	Clearances	8-57
Figure 8.11-A	Enclosed CT Meter Panel Heights & Minimum Clearances	8-57
Figure 8.11-B	Enclosed CT Meter Panel Heights & Minimum Clearances	8-59
Table 8.11-1	Conductors to Meter Panel Clearances	8-59
8.11.2.4	Wiring	8-59
8.11.3	Current Transformers	8-60
8.11.3.1	General	8-60
8.11.3.2	Types & Supply	8-60
8.11.4	CT Isolation	8-60
8.11.4.1	Single Occupancy	8-60
8.11.4.2	Multiple Occupancy	8-60
Figure 8.11-C	Typical Wiring Diagram for 4 CT Metered Occupancies and Proprietor with Direct Connected Metering	8-61
8.11.5	CT Enclosures	8-62
8.11.5.1	General	8-62
8.11.5.2	Location	8-63
8.11.6	CT Mounting	8-63
8.11.7	CT Meter Voltage and Current Wiring	8-64
8.11.7.1	Fuses	8-64
Figure 8.11-D	Busbar Arrangement to Provide for Safe Operation of Fuses	8-64
8.11.7.2	CT Wiring Loom	8-65
Figure 8.11-E	Dimensions of Current Transformers and Minimum Space Required in Enclosures for Current Transformers	8-66
Figure 8.11-F	Minimum Space Required in Enclosures for Current Transformers	8-67
Figure 8.11-G	Standard Current Transformer Meter Panel Layout	8-68
Figure 8.11-H	Typical Wiring Diagram for L.V. Current Transformer Metering	8-69
<b>8.12</b>	<b>Metering Communications Equipment</b>	<b>8-70</b>
8.12.1	General	8-70
8.12.2	Equipment	8-70
8.12.2.1	Location	8-71
8.12.3	Installation	8-71
8.12.3.1	Connection of Communication Power Supply	8-71
8.12.3.2	Communications Cabling, Communications equipment power cabling and antenna cabling	8-72
8.12.3.3	Communications Devices	8-72

## 8.1 Scope

These Rules apply to:

- all new and existing National Electricity Market (NEM) metering of (LV) energy from CitiPower, Jemena, Powercor, AusNet Services and United Energy Electricity Networks where the work is initiated by the customer;
- provisions related to embedded network LV metering;

NOTE: Rules for NEM High Voltage Metering are included in Section 9 “High Voltage Electrical Installations”.

Where a Rule requires clarification, or where a Rule does not apply or does not exist, the relevant Regulations and Codes apply and the Rules Management Committee or relevant Distributor should be contacted for advice in accordance with Clause 2.7 (SIR Management Committee Contact) and Section 3 (Distributor Areas and Contact Details).

The National Electricity Rules, Electricity Customer Metering Code and other documents administered by the Australian Energy Regulator, Australian Energy Management Operator (AEMO), Essential Services Commission (ESC) and Electricity Safety Act administered by Energy Safe Victoria contribute to these Rules.

This section is intended to provide all parties involved with LV electricity metering within Victoria with practical and detailed Rules that comply with all applicable regulations.

## 8.2 Tariffs & Metering Configurations

The customer or their agent shall consult with Retailers at the earliest opportunity to determine the available tariffs for their electrical installation so metering configurations can be determined and arranged accordingly.

Not all Retailers offer prescribed hours tariffs for loads such as off peak storage water and space heating.

Requirements for controlled load switching, via the meter, are associated with the relevant Network Tariff offered by the relevant Distributor, with details available via their website.

## 8.3 Metering Obligations

The National Electricity Rules prescribe separate meter/s for each individual NEM customer, except for where an un-metered (NEM type 7) supply has been agreed.

Metering equipment shall be supplied, installed and maintained by the Metering Provider and shall, unless otherwise agreed in writing, remain the property of the Metering Provider.

The customer shall provide and maintain facilities in accordance with the applicable Metering Regulations and Codes, the Electricity Safety Act and these Rules to accommodate the metering equipment supplied by the Metering Provider.

In general, this requires the customer to provide facilities that do not require the Metering Provider to interfere with the facilities and wiring to install the metering, other than that required to connect, fix and maintain the metering equipment and the metering communication equipment.



## 8.4 Metering Facilities

### 8.4.1 General

Meter mounting facilities shall be provided in one of the following arrangements:

- in an approved metering enclosure with the customer's switchboard equipment; or
- in an approved meters only enclosure; or
- on an approved surround; or
- within or on facilities that are acceptable to the relevant Distributor; and
- is of a type and in a location, accessible and prepared for the meters installation in accordance with these Rules.

However, facilities which meet equal or better outcomes than these Rules may be considered in accordance with clause 2.7 (SIR Management Committee Contact).

Direct metering enclosures and surrounds that are intended to be stocked and marketed by Electrical Wholesalers and similar Distributors are required to be accepted for use in accordance with clause 5.3 (Equipment Acceptance) prior to being connected to supply.

All metering panels, enclosures, surrounds and supplementary equipment shall comply with:

- The relevant Australian or IEC standard/s applicable at the time;
- The relevant Electricity Safety Regulations, Metering Codes of Practice and any Rules applicable at the time of connection to the electricity supply network; and
- Be suitable for use in normal service conditions to not cause the metering equipment to exceed its limits of operation in regard to current carrying capacity or operating temperature in accordance with clause 8.8 (Metering Equipment).
- Maximum value of system voltage expressed as a percentage of rated voltage i.e. 110%.
- Atmospheric Conditions - refer to Clause 3.3 of AS 60269.1 2005.

### 8.4.2 Timber Panels & Boards

Unless otherwise agreed with the relevant Distributor, where the customer initiates alterations or additions of existing metering, facilities that are in accordance with these Rules shall be provided.

#### 8.4.2.1

Where timber meter boards or panels exist, the Distributor may agree to its reuse subject to the board or panel:

- having sufficient space to adequately accommodate the intended equipment;
- having sufficient wiring space at the rear of the board or panel to accommodate the intended wiring, in accordance with Table 8.9-1;
- is installed in an enclosure consisting of, or lined with, fire resistant material; and
- being in serviceable condition and visual examination reveals no damage such as splitting, water or fire damage.

An existing multi-meter timber meter panel/board may be re-used in situations where the customer initiated work comprises the creation of an additional occupancy, within an existing multiple occupancy premises, provided the panel/board:

- Is in good condition;

- Can be manoeuvred easily, without placing undue stress on existing wiring and terminations;
- Has sufficient space to accommodate the additional meter and associated equipment;
- The customer agrees to supply certain equipment, eg. fuse bases and wedges, meter panel links, etc;

and the works are subject to job scoping by the Distributor, prior to physical connection.

(In this instance the timber meter board/panel will remain in the ownership/responsibility of the Distributor)

#### **8.4.2.2**

Replacement of the existing timber meter board or panel is required to fully comply with these Rules for the following:

- The customer agrees to supply certain equipment, eg. fuse bases and wedges, meter panel links, etc;
- Change of Supply Configuration;
- Rewiring/Upgrading Mains;
- Board Relocation;
- Additional Tariffs which incorporate additional meters and
- Surround or Enclosure upgrade.
- Where the meter board or panel is deteriorated or damaged.

(Under those situations, the replacement composite meter panel will be in the ownership/responsibility of the customer)

Where the Distributor agrees to the reuse of a timber meter board or panel the customer shall be responsible to provide acceptable fuses, links and equipment for the alteration to be performed by the Metering Provider.

Where a Metering Provider replaces a timber meter board or panel with meter facilities complying with these Rules, the ownership and responsibility for the upgraded facilities shall revert to the customer from the time of its installation.

### **8.4.3**

#### **Meter Panels**

#### **8.4.3.1**

##### **Size**

Meter panels shall be of a size to adequately accommodate the metering equipment to be installed upon it.

Unless otherwise accepted by the SIR Management Committee, the minimum size meter panel shall be 200 mm wide x 370 mm high and the maximum 600 mm wide x 900 mm high.

Consideration should be given to the possible future need for a larger size meter panel than the minimum size specified in these Rules to accommodate extra metering equipment if required.

#### **8.4.3.2**

##### **Installation**

Meter panels shall be hinged vertically:

- within an approved metering enclosure with the customer's switchboard equipment;  
or
- within an approved meters only enclosure; or
- on an approved surround; or

- on facilities that are acceptable to the relevant Distributor.

#### 8.4.3.3 **Materials**

A3

Meter panels shall be constructed of insulating material:

- to AS/NZS 61439 or equivalent IEC standard; and
- suitable for its intended use and environment, including exposure to ultra violet where exposed to daylight.

#### 8.4.3.4 **Wiring Holes**

Meter Panels shall be equipped with wiring holes:

- to suit each particular metering installation in accordance with the applicable Figures in this section;
- of a size and shaped to enable free movement of cables through the panel and termination of the conductor/s without damage to the cable insulation; and
- Un-used wiring holes shall be sealed in accordance with the Wiring Rules

A2

Holes for ELV and communications cabling shall be separate from LV cable holes.

#### 8.4.3.5 **Fixing and Sealing**

The meter panel shall be:

- hinged mounted on one vertical edge of the panel and secured to the metering enclosure or surround;
- capable of being opened to an angle of not less than 80 degrees from the closed position with all metering equipment installed;
- equipped with hinges:
  - constructed of a suitable non-corroding material that will maintain a structural and dimensional fit after metering equipment has been installed;
  - of a lift-off double off-set type for meter panels installed within enclosures;
  - of a lift-off type for meter panels on surrounds;
- secured in the closed position by a metal fastener or fasteners which requires the use of a tool to release; and
- able to be easily fitted with a seal to seal the panel in the closed and fastened position. A 1.6 mm – 2 mm diameter hole is to be provided for the attachment of a seal.

#### 8.4.3.6 **Labelling**

All meter panels shall be labelled with the correct street address and the specific labelling requirements required in Clauses 8.10.1.4 and 8.10.2.10. Labels shall be in accordance with clause 5.4 (Labelling) and shall remain clearly visible after installation of all equipment.

#### 8.4.3.7 **Wiring**

Meter panel wiring shall be:

- arranged and installed in accordance with these Rules the Wiring Rules and any additional Metering Provider specifications.
- contained in an area capable of being sealed with a Metering Providers seal where it is un-metered single insulated wiring.

Wiring not intended for connection to the metering equipment shall not be located in the wiring space directly behind the meter panel/s. Such wiring shall be contained within a physically separate duct or conduit located in a rear corner of the enclosure or surround so that it does not obstruct the meter wiring space. Notwithstanding the above, builder's supply meter combination switchboard mounted on a builder's supply pole and earthing conductors are permitted.

Wiring not intended for connection to a Metering Provider's metering equipment shall not be located anywhere on the front of the metering panel or in a position which will obstruct the metering equipment.

Meter related communications cabling, owned by the Metering Provider, can be located behind the meter panel provided it is insulated to the highest voltage present.

Unused meter panel wiring shall be terminated in accordance with the Wiring Rules. Acceptable methods to comply with these requirements include connection of all metering equipment to the panel at the same time, or to ensure unterminated wiring is appropriately insulated and terminated at the rear of the panel or within a junction box. Supply may be withheld from any meter panel with exposed conductors.

**Exception:** For group meter panels, where the depth behind the meter panels is greater than 75mm, wiring not associated with the individual meter panel and is not intended to be terminated on that panel is permissible providing the wiring is loomed and located at a depth greater than 75mm behind the panel or enclosed within a wiring enclosure located outside the 75mm space at the rear of the panel.

## 8.4.4 Metering Surrounds and Enclosures

### 8.4.4.1 General

Meter Surrounds and Enclosures shall be constructed:

- to accommodate a meter panel in accordance with these Rules;
- to have the meter panel and meter wiring separate and segregated from any other area and wiring;
- to prevent the spread of fire in accordance with the requirements of the Electricity Safety Act for construction of switchboard cases and surrounds;
- to prevent direct contact by persons with wiring at the rear of the meter panel when the meter panel is in the closed position;
- to provide a minimum clearance at the back of the meter panel not less than that detailed in Table 8.9-1;
- to be provided with suitable fixing devices to allow the meter panel to be fixed and sealed in position in accordance with clause 8.4.3.5 (Fixing and Sealing) when closed; and
- to ensure movement of the meter panel is not obstructed and the device used to retain the hinged meter panel in the closed position is in correct alignment when all necessary equipment is mounted on the meter panel.

### 8.4.4.2 Meter Surrounds

Meter surrounds shall be constructed to the depth specified in Table 8.9-1, to accommodate the meter wiring and to support the meter panel as specified in Table 8.10-1 and 8.10-2, and be constructed:

- to the specifications of clause 8.4.4.1 (General) and Figure 8.10-F;
- of sheet steel, not be less than 1.2 mm thick unless an acceptable strength is achieved with a thinner sheet which is reinforced by the manufacturing process or design or other material; and

- hot dipped galvanised with a coating weight of Z275 in accordance with AS 1397; or
- where painted, pre-treated in accordance with the paint supplier's recommendation and coated with a material such as powder coating or baked enamel giving a hard, durable finish with a service life of not less than 20 years; and
- with characteristics, equal to or better than steel where materials other than steel are used. e.g. well seasoned timber (lined with fire resistant material), polycarbonate, fibreglass, etc.

#### 8.4.4.3 Meter Enclosures:

Meter enclosures shall take the form of a box type enclosure that accommodates the meter panel, metering equipment and may also accommodate a switchboard.

Meter enclosures shall be:

- constructed with materials specified in clause 8.4.4.2 (Meter Surrounds) and installed in a manner so that the metering equipment is completely enclosed and effectively protected from the environments it is installed in.
- provided with a clearance between the front of the meter panel and the back of the enclosure door of not be less than 175 mm for direct connected metering and Current Transformer metering.
- designed for construction and location not to cause the metering equipment to exceed its limits of operating temperature in accordance with clause 8.8.2.

If the door of the meter enclosure is to be utilised to support an antenna for meter communication, the door shall not be removable.

##### (a) Type not exposed to Weather or Adverse Environment

A meter enclosure not exposed to the weather may be constructed of any suitable material and may or may not be equipped with a door.

Meter surrounds may only be installed within these enclosures if the conditions of all of these Rules relating to access and the ability to work on the metering equipment can be met.

##### (b) Type exposed to Weather or Adverse Environment

Meter enclosures exposed to the weather or adverse environment shall take the form of a box type enclosure equipped with a hinged door secured by an effective self operating latch and be of sufficient strength and design to withstand all reasonable elements of its installed environment and be constructed:

- to accommodate the meter panel and equipment to the specifications of clause 8.4.4.1 (General) and Figure 8.10-E;
- to support the meter panel as specified in Table 8.10-1 and 8.10-2;
- to provide depth behind the panel specified in Table 8.9-1;
- with ventilation and draining that will minimise condensation and provide for draining of moisture that might collect in the enclosures;
- to ensure the operating temperatures stipulated in clause 8.4.1 are not exceeded;
- with an IP rating, suitable for the installed environment, and a minimum degree of protection of IP23, in accordance with AS60529;
- with a hinged door fitted with:
  - a retainer when the door is open, and in a position to enable work to be performed on the meter panel and equipment safely, and without interference; and

- a self-operating latch that is easily unlatched to open the door, and which retains the door in the closed position under all conditions that can reasonably be expected; and
- a Victorian Power Industry type lock in accordance with clause 5.6.2 and 8.6.3 when installed in public land, isolated and unattended locations and where locking is considered necessary by the customer or otherwise required by these Rules.

#### **8.4.4.4 Acceptance & Marking**

Direct metering enclosures and surrounds that are intended to be stocked and marketed by Electrical Wholesalers and similar Distributors are required to be accepted for use in accordance with clause 5.3 (Equipment Acceptance) prior to being connected to supply.

Conditions for the acceptance of this metering equipment may be obtained by contacting the Management Committee in accordance with clause 2.7 (SIR Management Committee Contact).

Direct metering enclosures and surrounds that are required to be accepted shall be permanently labelled with the acceptance number provided by the Committee.

#### **8.4.5 Equipment**

##### **8.4.5.1 Acceptance**

Meter surrounds and enclosures that have been accepted in accordance with clauses 8.4.4.4 (Acceptance & Marking) and 5.3 (Equipment Acceptance) are suitable for connection to electricity supply networks.

Meter panels, surrounds and enclosures that have not been submitted and approved by the Service and Installation Rules Management Committee will be subject to approval by the Responsible Officer before connection to the electricity supply network.

Enclosures and Switchboards containing metering equipment, shall be designed for construction and location to ensure the metering equipment does not exceed its temperature limits of specified operating range as specified in clause 8.8.2 and certified evidence to this effect shall be provided by a NATA testing laboratory or temperature rise assessment by extrapolation certified by a suitably qualified engineer.

Refer to Section 5 General Rules for information regarding equipment acceptance and suitability of equipment.

##### **8.4.5.2 On Meter Panels or Within Enclosures**

Unless otherwise agreed in writing, equipment other than that required for Electricity Supplier metering purposes, or as detailed in these Rules for a pole mounted builder's supply as shown in Figure 8.10-G shall not be installed on the meter panel unless permitted by the Electricity Safety Act and Regulations and these Rules.

Only communications equipment installed by the Metering Provider is permitted to be located on the meter panel.

Customer's monitoring or metering equipment, including its associated cables shall not be located:

- On the same meter panel as the Metering Provider's equipment.
- In front of the meter or any clearance space on the meter panel or behind the meter panel.

Equipment installed on meter panels shall be mounted to allow sufficient space to accommodate all equipment to be installed upon the panel in a manner which enables connection, disconnection and reconnection of all wiring and access to all terminals without dismantling other equipment or creating a need to remove covers of equipment other than that being worked upon.

A2 |

A2 | Equipment shall be securely fixed to meter panels in accordance with the Wiring Rules. Fixing screws and fasteners shall not protrude through the rear of the panel in a manner that could damage conductors or create un-earthed exposed metal.

### 8.4.5.3 Sealing & Locking

**FAQ 010**

Access to terminals of un-metered equipment shall be restricted by means of sealing or locking with the use of a Distributor's padlock. Such terminals shall be segregated from terminals of metered equipment by barriers or other suitable means.

All switches in un-metered circuits shall have provision for locking in the open (off) position.

A3 | All un-metered switches controlling CT metering associated with Safety Services, shall have provision for locking in the closed (on) and open (off) positions. Locking facilities shall be capable of accepting a Distributor lock.

A 1.6 mm – 2 mm hole shall be provided in covers or facilities to fix covers of all un-metered equipment terminals for the Metering Provider to fit seals to prevent unauthorised access to the terminals.

A3 | All locking facilities shall be permanent and fit for purpose.

Refer to clause 7.10.8 for labelling requirements.

## 8.5 Access

### 8.5.1 General

A2 | The customer shall provide convenient and unhindered access to metering locations and equipment, and all other supply related assets as follows:

- Meter installation, reading and planned maintenance, as a minimum between the hours of 9.00 am to 5.00 pm Monday to Friday;
- At all times for supply and metering fault rectification; and
- At any other time agreed by the Distributor or Metering Provider and the customer or customer's agent.

Meters shall be located in accordance with clause 8.6 (Location).

All occupants shall have common right of access to their occupancy's meter equipment located in a group meter location within a multiple occupancy electrical installation.

Unless otherwise agreed with the relevant Distributor access to metering equipment shall be via the closest, shortest and most convenient public pedestrian route to and within the property.

A3 | The preferred location of metering is at the ground floor level and accessible to the general public. If metering is located in a basement, access shall be via one pedestrian door and keyed with a VPI2 key. The metering shall be not more than 10 meters from the access door and not more than one level below ground level. The Responsible Officer shall be consulted prior to locating any metering in a basement.

Unless otherwise agreed with the relevant Distributor or Metering Provider, the metering equipment shall be accessible in areas to eliminate the necessity to enter secured areas and rooms or areas that are not normally entered by visitors or available for public access.

Access to and the area around the metering equipment shall be kept clear, unobstructed, safe and clean and free of rubbish.

Where metering equipment is installed in a room or area set aside for the purpose, such room or area shall be provided with adequate illumination to AS/NZS 1680 for access.

Any elevated floor or platform used to provide access shall be fitted with a substantial and permanent railing unless otherwise approved by the Responsible Officer.

Access to elevated positions shall be provided by an approved fixed stairway or ramp and handrail in accordance with the Building Code of Australia. Access by means of a ladder either fixed or portable is not acceptable.

Where a perimeter fence restricts access between the metering equipment and public access point, the metering equipment shall be conveniently and safely accessible from the public access side of the fence or provide access arrangements in accordance with clause 8.5.2 (Locks). The customer shall ensure that access is not subsequently restricted, or the location otherwise rendered unsuitable. Should this occur, the customer shall restore suitable access or arrange for the relocation of the metering equipment or provide access arrangements in accordance with clause 8.5.2 at the customer's expense.

Access arrangements to metering equipment associated with the following examples of electrical installations may be varied by agreement with the Distributor;

- Multi level buildings;
- Shopping centres complex;
- Hospitals;
- Remand Centres & Prisons;
- Manufacturing premises;
- Refineries;
- Sites incorporating indoor type substations;
- Proprietor services eg. public light, Safety Services, etc.

### 8.5.2 Locks

Where locks are considered necessary by the customer or are required by these Rules, the customer shall arrange for the lock/s to be installed in accordance with Clause 5.6.2 (Victorian Power Industry Lock).

Locks shall be used only on doors or gates which provide access to the property and/or to an enclosure or room housing metering equipment and shall be accessible from outside the door or gate.

## 8.6 Location

### 8.6.1 General

**FAQ 007**

All meters (manual and remote read) shall be located in accordance with these Rules to enable safe and unhindered access in accordance with clause 8.5 (Access) for installing, fixing, reading, testing, maintenance and removal of metering equipment without difficulty or hazard.

For electrical installations on properties exceeding 4,000 m<sup>2</sup> in area, the Responsible Officer shall be consulted regarding a suitable meter location.

### 8.6.2 Rooms

The door/s of rooms and enclosures housing metering equipment shall be labelled "Electricity Meters". If the door is to be locked it shall be locked with a VPI lock in accordance with clause 8.5.2 (Locks) and 5.6.2 (Victorian Power Industry Lock).

### 8.6.3 Public Land

Where metering equipment is required to be installed on Public Land in accordance with clause 5.7 (Private Electric Lines in Public Land) it shall be located in a secure enclosure or premise which is at least 2m from a Distributor pole or substation and 1m from a service pit.

Unless otherwise agreed with the relevant Distributor access to metering equipment shall be via the closest, shortest and most convenient public pedestrian route.



A3 | Refer to Clause 8.6.4 Unsuitable Metering Locations.  
Adequate locking facilities shall be fitted to the metering enclosure entry in accordance with clause 5.6.2 (Victorian Power Industry Lock).

#### 8.6.4 Unsuitable Metering Locations

Metering equipment shall not be installed in the following locations:

- Behind a security door or gate which is capable of being locked unless, subject to the approval of the Responsible Officer, the door or gate is fitted with a “Power Industry Lock” Clause 8.5.2 – (Locks);
- Areas where special entry conditions are applicable eg. educational institutions, kindergartens, religious centres, childcare centres, banks, government buildings, etc.
- Areas to which access is normally restricted – for security, health or other reasons including enclosed verandas and areas or yards which may be locked or house animals;
- Where public access is not normally permitted (typically, road reserves, median strips, traffic islands, rail corridors or where traffic control is required)
- Gender specific areas;
- Areas intended for product display - such as shop windows;
- A carport associated with a single occupancy unless access to the main entrance of that occupancy is gained only through the carport, or after consultation with the Responsible Officer, there is no other available location;
- On a single occupancy building, over an external elevated area which is greater than 3.0m above finished ground level at the point at which access is obtained. (Refer Figure. 8.10-C);
- Above a gas meter, except where shown in Figure 8.10-D;
- Where the use of a ladder would be necessary;
- Over stairways, landings, ramps, in narrow passageways or in other confined spaces;
- Vehicle loading docks, car parks, driveways and factory passageways where the metering equipment is not accessible (refer to 8.5 – Access) or effectively protected;  
Note 1: the intention is not to locate metering enclosures in a position where they can be struck by a reversing or turning motor vehicle.  
Note 2: Car parks include driveways where vehicles are parked either temporarily, permanently or designated as a car parking area.
- Positions in close proximity to or over machinery or open type switchgear;
- Below areas where ice or snow can accumulate and fall on persons accessing the metering equipment;
- Locations liable to be affected by fumes, dampness, flooding, dust, noise, vibration, heat or other external factors that may cause deterioration of equipment or unsatisfactory working conditions;
- Rooms containing refuse bins, compactors, or used for storage
- Wet areas as defined in the Wiring Rules;
- Hazardous Areas as defined in the Wiring Rules;
- Where the temperature on the case of the meter exceeds 60 degrees C.  
NOTE: the meter heat contribution can be up to 25 degrees C as per AS62052;
- Where exposed to weather unless installed in a suitably approved enclosure;
- Where there is insufficient light;

- In fire isolated stairways, passageways or corridors;
- Where access is restricted by vegetation;
- Where projections at head height would pose a hazard; and
- In close proximity to radio transmitters; eg Telecommunications / broadcast or HAM radio operations.

## 8.7 Protection against Damage to and Interference with Metering Equipment,

The customer shall provide adequate and appropriate protection methods to prevent any physical damage to metering equipment.

The metering equipment and facilities shall be adequately protected against advertent and inadvertent damage, including: mechanical damage, vibration, effects of the weather, sea air, corrosion, vandalism etc.

Examples of appropriate protection methods may include one or more of the following methods:

- Where metering is incorporated in a structure of sufficient structural integrity, e.g. brickwork or masonry blocks or provided with a minimum protection to WSX3 as detailed in AS/NZS 3000.
- Where metering is installed in a location that is protected from the weather in accordance with the Electricity Safety Act and Regulations, the metering equipment shall be located:
  - in a meter enclosure; or
  - on a hinged meter panel mounted on a suitable metering surround.
- Where metering is installed in locations exposed to the weather the metering shall be installed in suitable enclosures conforming to these Rules;
- Where protection against vandalism is required, the metering enclosure shall be locked in accordance with Clause 5.6.2 (Victorian Power Industry Lock or CL001 Key).

## 8.8 Metering Equipment - Limits of Operation

### 8.8.1 Direct Connected Meter - Limits of Current Carrying Capacity

The maximum current rating of direct connected meters is 100 amps which shall not be exceeded. The maximum demand, as determined under the Wiring Rules, of any electrical installations shall be limited by a main switch/es circuit breaker/s to ensure the current rating of direct connected meters is not exceeded.

Where the maximum demand of electrical installations cannot be limited accordingly, CT metering shall be required.

Note: For information related to circuit breakers refer to clause 6.7.1.2 (Electrical Installations subject to a specific electricity distribution connection agreement, contract or a deemed electricity distribution contract).

Sites designed with a determined maximum demand approaching 80 A per phase or more, should strongly consider installation of LV CT Metering from the outset, to avoid re-work due to load growth.

### 8.8.2 Meters - Temperature Limits of Specified Operating Range

Metering Facilities and enclosures shall be designed to ensure the meter is not at any time subjected to temperatures in excess of its specified operating range conditions as defined by table 5, of NMI M6 -1 as published by the National Measurements Institute and in accordance with the National Measurements Act.

Unless otherwise defined by NMI M6-1 this should be interpreted as:  
 Direct Connected Metering (class 1 or 1.5): -10°C to +60°C  
 LV CT and HV Connected Metering (class 0.2 or 0.5): -10°C to +45°C

Appropriate air circulation, ventilation, shading or siting of the metering equipment should be considered in meeting those operating temperature limits.

Where metering is enclosed within the customer’s switchboard, a temperature rise limit (above ambient) of 10°K is to be used for LV CT and HV Connected meters, and 25°K is to be used for Direct Connected meters, when installed as “built-in components” within the customers Switchboard. Those temperature rise limits shall be used for meters installed as “built-in components” for the purposes of type tests or extrapolation of partial type tests as described in AS/NZS 61439, and for the purposes of type tests to AS/NZS 61439 by actual test of temperature rise, or temperature rise assessment by extrapolation under AS60890-2009.

A3

## 8.9 Direct Connected Metering

### 8.9.1 Meter Panels

Meter panels supplied in accordance with Clauses 8.3 (Metering Obligations) and 8.4.4 (Metering Panels, Surrounds and Enclosures) shall be arranged and not less than the sizes detailed in Clauses 8.9.3.2, 8.10.1.2 and 8.10.2.9 (Single/Multiple Occupancies) for the relevant size of conductors and the number and type of metering installations.

The Responsible Officer should be consulted for arrangements other than those covered by Tables 8.10-1 and 8.10-2

### 8.9.2 Meter Panel Heights and Clearances

**FAQ 023**

Unless otherwise approved by the Responsible Officer, direct metered electrical installations shall be arranged to meet the clearances provided in Figure 8.9-A (Meter Panel Heights and Clearances):

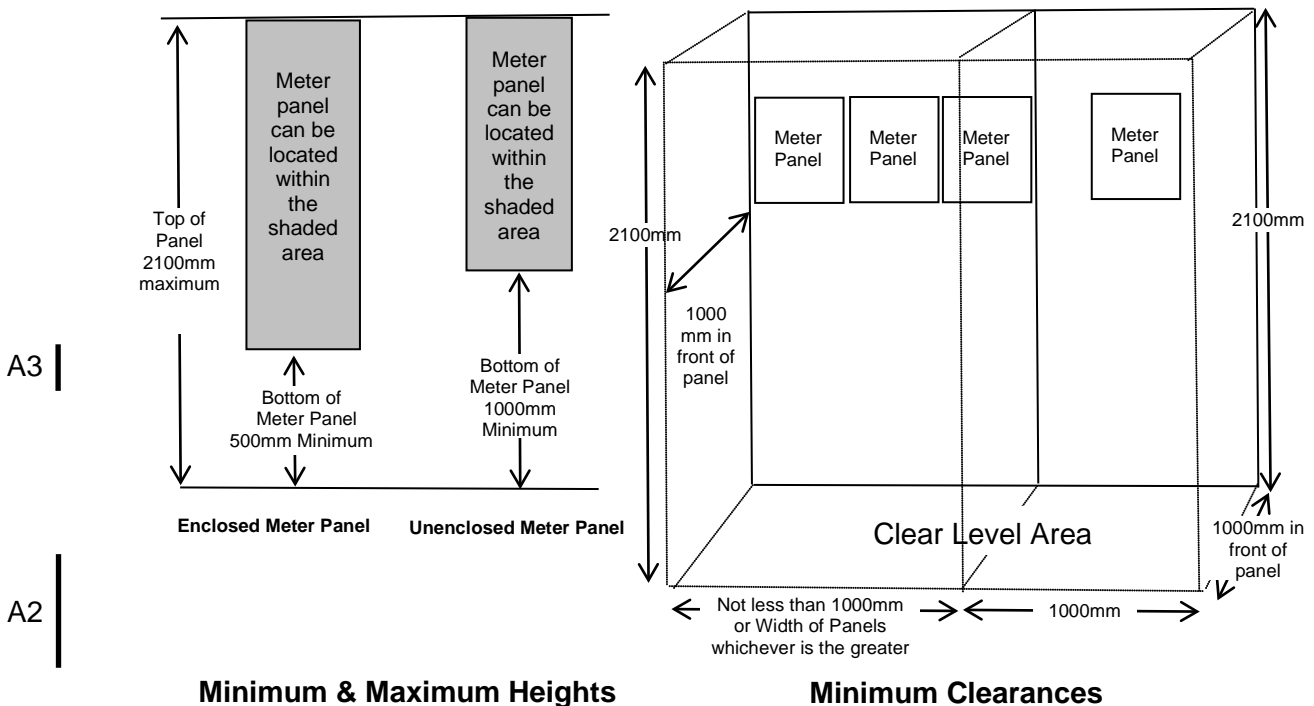

A3

A2

**Figure 8.9-A Meter Panel Heights & Minimum Clearances**

A2 | Any doorways or opening providing access to meter panels shall be a minimum of 2 m H x 0.6 m W.

### 8.9.3 Meter Wiring

#### 8.9.3.1 General

Meter wiring shall be installed in accordance with the Electricity Safety Act and Regulations and these Rules:

- The wiring shall be designed and installed to withstand any thermal and magnetic effects on the conductors;
- Where provision is made to hinge or remove switchboard panels, or conductors connected to the electrical equipment on the switchboard panel, the conductors shall be provided with sufficient free length to allow the meter panel to be moved into a position to enable work to be carried out;
- All conductors shall be suitably fixed or otherwise retained in position to avoid undue movement or stress at terminals of electrical equipment when the panel is moved or is fixed in position; and
- The conductors shall be labelled to indicate line and load, phase colours and the associated neutrals identified; and
- The conductors shall be sized to the load they are to carry in accordance with the Wiring Rules.

#### 8.9.3.2 Meter Panel Conductors

Only soft drawn multi strand copper conductors or flexible conductors with suitable ferrules of the following sizes and types shall be provided.

**Table 8.9-1 Meter Panel Conductor Specifications and Limitations**

<b>Conductors Sizes</b>			
Load Carrying Conductors	≥ 4 mm <sup>2</sup> to ≤ 35 mm <sup>2</sup>		
Metering Neutral Conductors	4 mm <sup>2</sup> or 6 mm <sup>2</sup> and coloured black		
Meter Register Changeover Switch Wire/s	Not required		
<b>Soft Drawn Copper Conductors</b>	<b>Minimum Number of Strands</b>		
≥ 2.5 mm <sup>2</sup> to ≤ 16 mm <sup>2</sup>	7 strands		
≥ 25 mm <sup>2</sup> to ≤ 35 mm <sup>2</sup>	18 strands		
<sup>(3)</sup> <b>Flexible Cables</b>	<b>Required Ferrule Size</b>		
25 mm <sup>2</sup>	≥ 22 mm long and ≤ 8 mm diameter		
≤ 16 mm <sup>2</sup> cables	≥ 18 mm long and ≤ 8 mm diameter		
<sup>(2)</sup> <b>Maximum Size of Soft Drawn Copper Conductors and Depth behind panel</b>			
<b>Maximum Conductor Size</b>	<sup>(4)</sup> 16mm <sup>2</sup>	16mm <sup>2</sup>	35mm <sup>2</sup>
<b>Minimum Depth behind panel</b>	<b>50 mm</b>	<sup>(1)</sup> <b>75mm</b>	<b>150mm</b>
<b>Footnotes.</b>			
<sup>(1)</sup> This depth can also accommodate no more than four 25 mm <sup>2</sup> conductors attached to the meter panel.			
<sup>(2)</sup> The maximum sizes specified in this table may not be applicable where the use of flexible conductors are incorporated to ensure adequate flexibility.			
<sup>(3)</sup> Flexible cables used for meter panel wiring shall be provided with end-terminals (boot lace ferrules).			
<sup>(4)</sup> Only to be used where;			
<ul style="list-style-type: none"> <li>• Consumer's mains comprise of 16mm<sup>2</sup> soft drawn copper conductors forming a 2 Wire 230 volt Single Phase, single occupancy installation.</li> <li>• 4 mm<sup>2</sup> permitted for any controlled loads.</li> <li>• Cables located at the rear of the meter panel shall be arranged in accordance with the relevant clause contained in the Wiring Rules to prevent undue stress on the conductors or their terminations.</li> </ul>			

### 8.9.3.3 Wiring Arrangements

Typical metering layout and wiring arrangements are shown in Section 8 Figures. Meter wiring diagrams specific to particular network tariffs are available from the relevant Distributor. Refer to each Distributor's website. Details of off peak load control arrangements should be obtained from the Electricity Supplier in accordance with clause 8.2 (Tariffs and Metering Configurations).

The wiring of each metering panel shall:

- have the metered and un-metered conductors installed, prepared, connected and arranged to conform with the metering arrangements to suit the tariffs selected by the customer and ready for the installation of the metering equipment;
- conform with that shown in the wiring diagram for the relevant electrical installation type;
- be identified in accordance with clause 7.5.1.4 (Colours and Double Insulation);
- have the sheath removed and a length of single insulated cable between 100 mm and 150 mm through suitable holes in the correct positions ready for connection to the metering equipment as shown in Section 8 Figures ; and
- be permanently labelled at the rear of the meter panel to indicate the function of the conductor, ie, line/load, hot water, etc for the wiring to be terminated by the meter installer.

The incoming neutral conductor to a neutral link shall be clearly identified as such. Neutral conductors for each meter and time switch shall be coloured black and originate from a terminal of the neutral link. Looping of neutral conductors between terminals of equipment is not acceptable.

Active conductors may be looped at line terminals of equipment where a separate terminal is provided for this purpose.

Refer to clause 8.4.3.7 for unused meter wiring.

### 8.9.3.4 Remote Meter Enclosure Earthing

Where a remote metering enclosure without a switchboard is required to be earthed and an earthing conductor is not installed between the meter enclosure and the switchboard, the typical earthing arrangement is shown below in Figure 8.9-B.

A3

A3

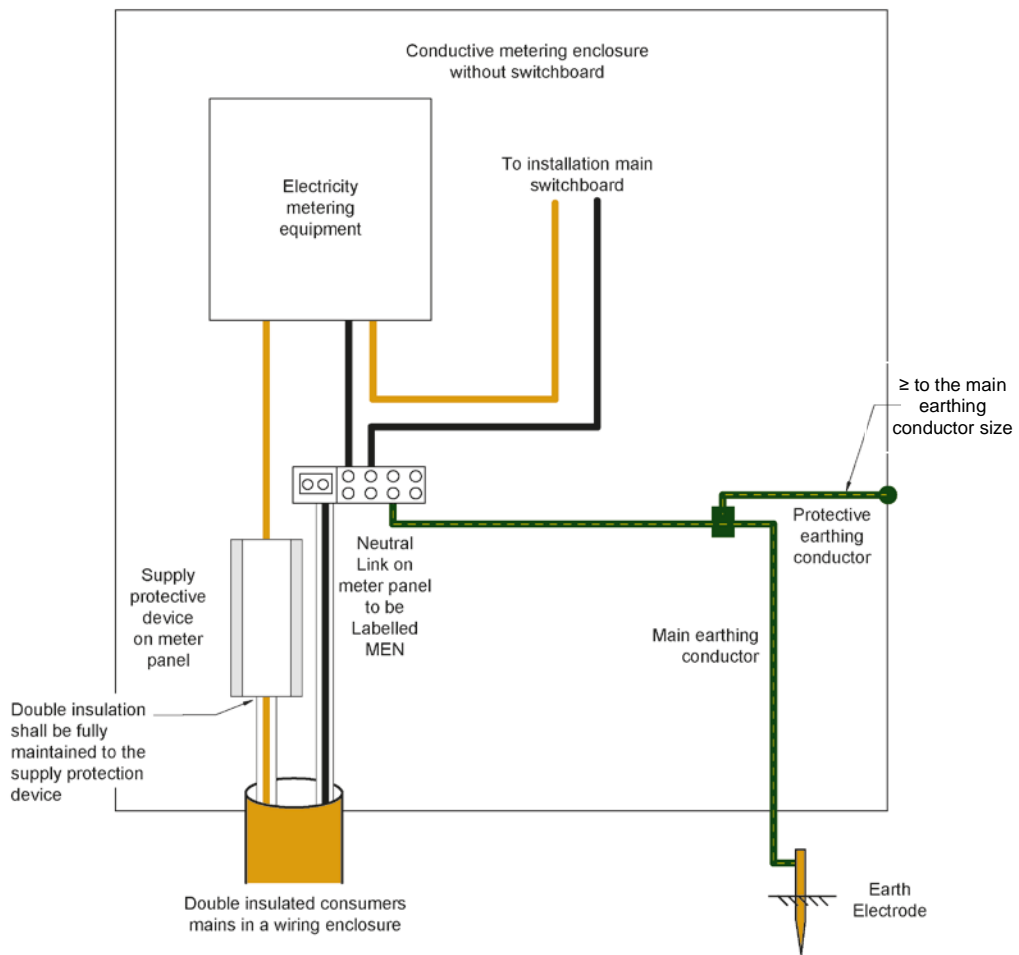

**Figure 8.9-B Typical Arrangement of Earthing of Remote Metering Enclosure Without a Switchboard**

**8.9.4 Equipment**

Where applicable the customer’s agent shall arrange for the supply, installation and wiring of:

- Supply protection devices in accordance with clause 7.3.2.5, 7.4.4.9 or 7.5.3.1;
- Occupancy Disconnection Devices in accordance with clause 8.10.2.12;
- Neutral and active links; and
- And other equipment required by the Metering Provider.

Meter panel fuses shall be spaced not less than 20 mm apart where a maximum demand exceeds 50 Amps per phase, to enable effective dissipation of the heat generated.

Meter wiring links shall:

- be of sufficient current carrying capacity equal to or greater than the current to be carried by the link;
- have separate terminals for each conductor terminated in the link where practical;
- be mounted on the face of the meter panels for single occupancies as shown in metering diagram figures; and
- for multiple occupancies, may be mounted on the face of the meter panels or within a sealed section behind the meter panels subject to maintaining the required depth;

- be fitted with a removable insulating cover with:
  - the cover fixing screws secured within the cover when the cover is removed; and
  - sealing facilities to seal the cover to the link's base.

Phase identification of active links shall be permanently and indelibly marked.

Single occupancy neutral links shall be:

- a minimum rating of 100 Amp and 500 Volt; and
- equipped with the terminal for the incoming main neutral conductor clearly identifiable by means of a clamping plate terminal set at an angle for ease of conductor access and termination without accessing the rear of the panel.

Incoming mains or sub main neutral link arrangements shall be such that these conductors can be disconnected conveniently from the front of the meter panel for testing purposes.

## 8.10 Specific Situation Requirements

### 8.10.1 Single Occupancy

#### 8.10.1.1 Isolation

Single occupancy metering equipment shall be capable of being isolated by the removal or opening of the supply protection device/s.

Additionally, where an overhead service has been provided to a commercial premises in accordance with clause 7.4.4.4 and the supply protection devices cannot be operated by a fuse stick from the ground, the direct connected meter shall be capable of being isolated by meter panel fuse/s installed upon the same panel as the occupancy metering. The fuse/s shall be of a type that complies with clause 6.8.5.3.1. The relevant Distributor will supply and install the fuse cartridge/s and seal the fuse assemblies.

#### 8.10.1.2 Meter Panels

All metering shall be contained on a single panel.

**Table 8.10-1 Single Occupancy Typical Meter Panel Sizes**

Metering Required	Minimum Panel Size mm Width x Height
Single phase, 2 Wire	200 x 370
1 x Multi-phase	400 x 380

#### 8.10.1.3 Meter Locations

##### 8.10.1.3 (a) Domestic

Unless otherwise agreed with the relevant Distributor the metering equipment shall be located:

- on the face of the residence toward a street or along the adjacent side wall within 1.5 m of that face or an associated corner window of the residence to which unhindered pedestrian access exists and will be maintained; and
- not further than 1.5 m beyond the main entrance where the main entrance is on the side of the residence, subject to access being available.

Suitable locations are shown in Figure 8.10-A

A3

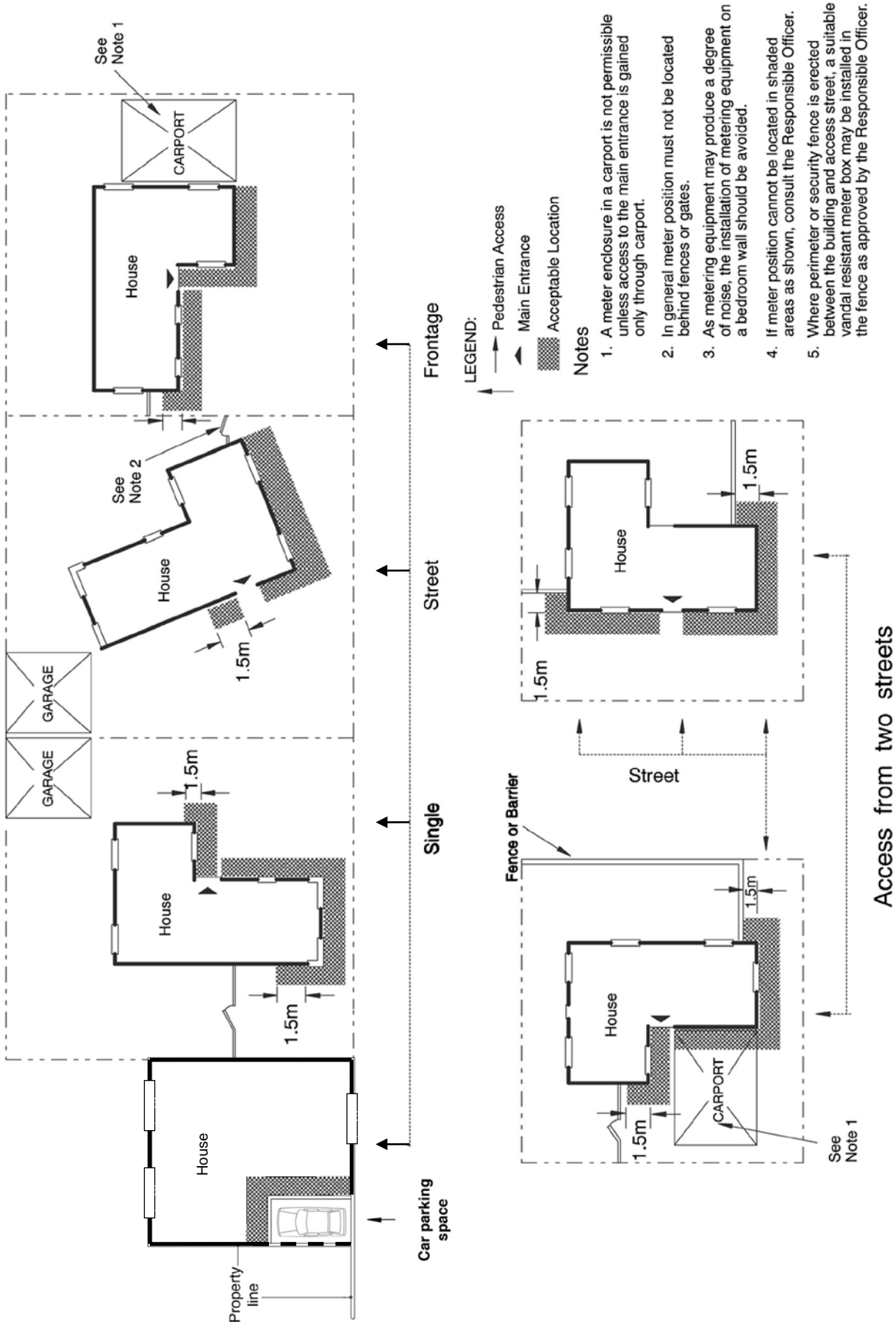

**Figure 8.10-A Individual Electrical Installations Acceptable Meter Locations**



### **8.10.1.3(b) Commercial / Industrial Meter Locations**

Unless otherwise agreed with the relevant Distributor the metering equipment shall be located:

- on the face of the building toward a street or along the adjacent side wall within 1.5m of that face or an associated corner window of the building to which unhindered pedestrian access exists and will be maintained; and
- not further than 1.5m beyond the main entrance where the main entrance is on the side of the building, subject to access being available; or
- within a suitable location in the building where suitable locations outside of the building do not exist.

Suitable locations are shown in Figure 8.10-B

### **8.10.1.4 Labelling**

Every single occupancy meter panel shall be equipped with a label in accordance with clause 5.4 (Labelling) displayed on the meter panel indicating the correct street address obtained from the local municipal council.

### **8.10.1.5 Neutral Links**

Single Occupancy neutral links shall comply with clause 8.9.4

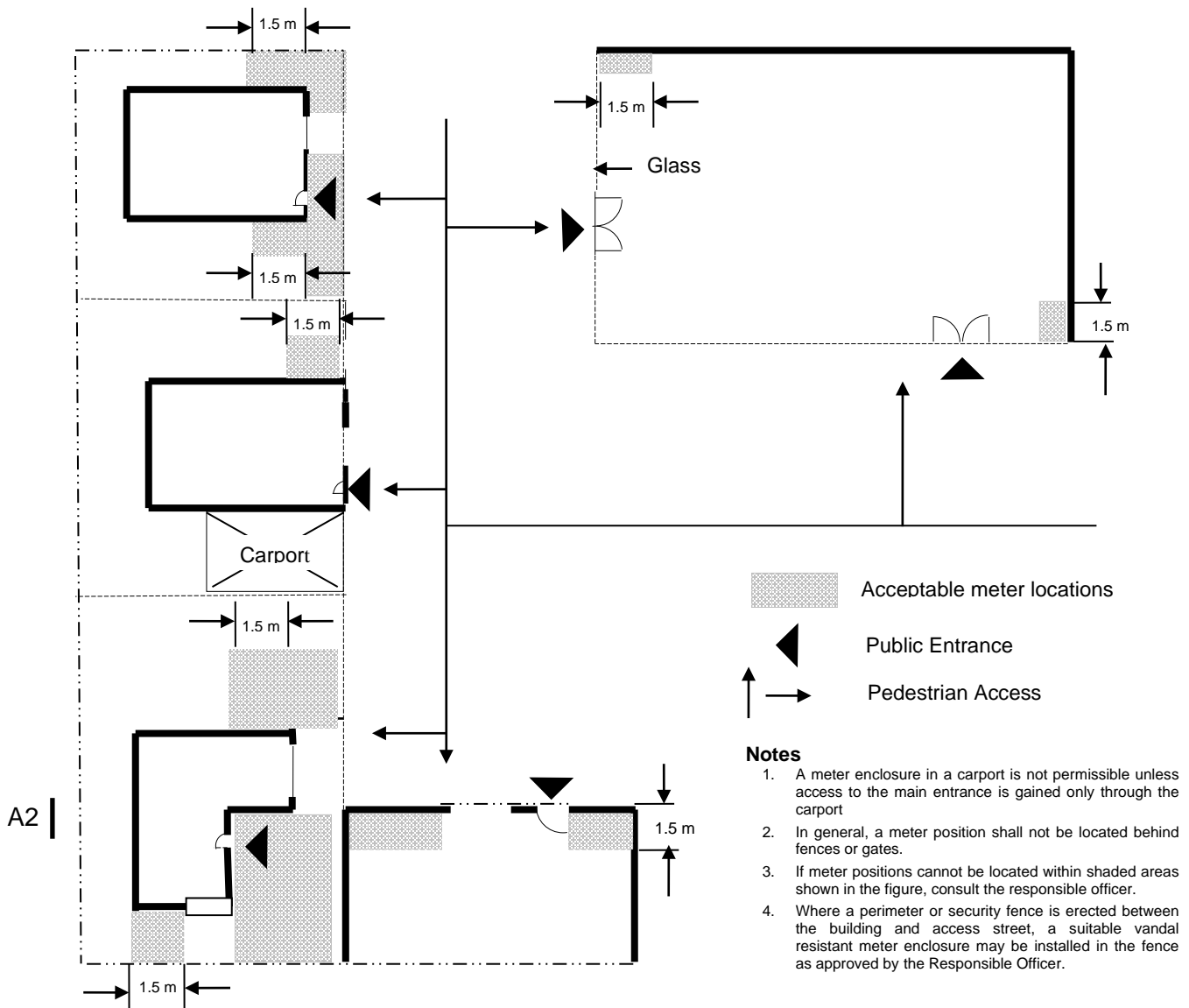

**Figure 8.10-B Small/Medium Individual Commercial/Industrial Installations Acceptable Meter Locations**

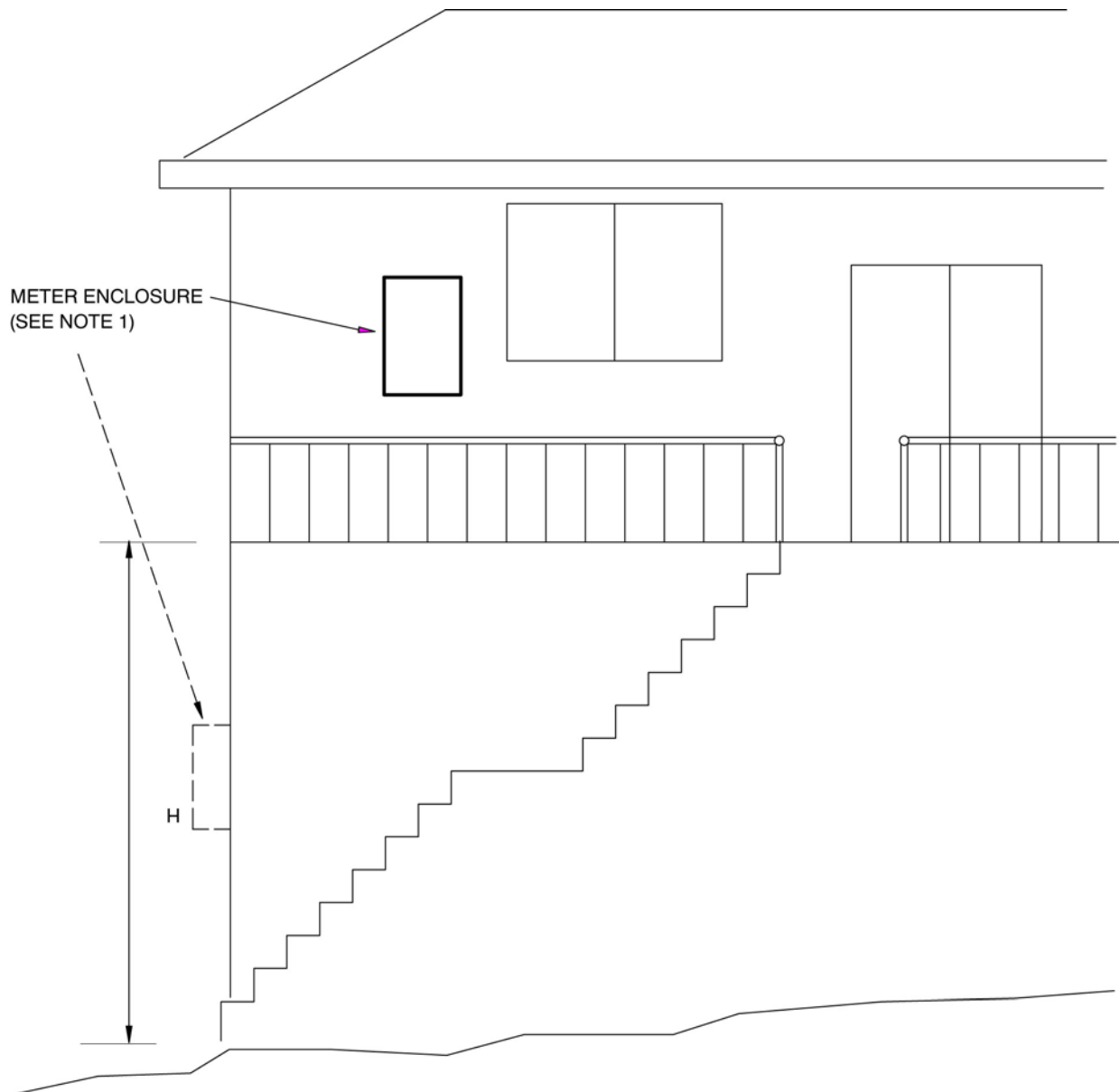

### Notes

1. If dimension 'H' exceeds 3.0m, metering equipment shall be installed on lower portion of structure.
2. Meter locations must also comply with the conditions shown in Figures 8.10-A, 8.10-B and 8.10-D

**Figure 8.10-C Acceptable Meter Locations for Elevated Premises**

A3

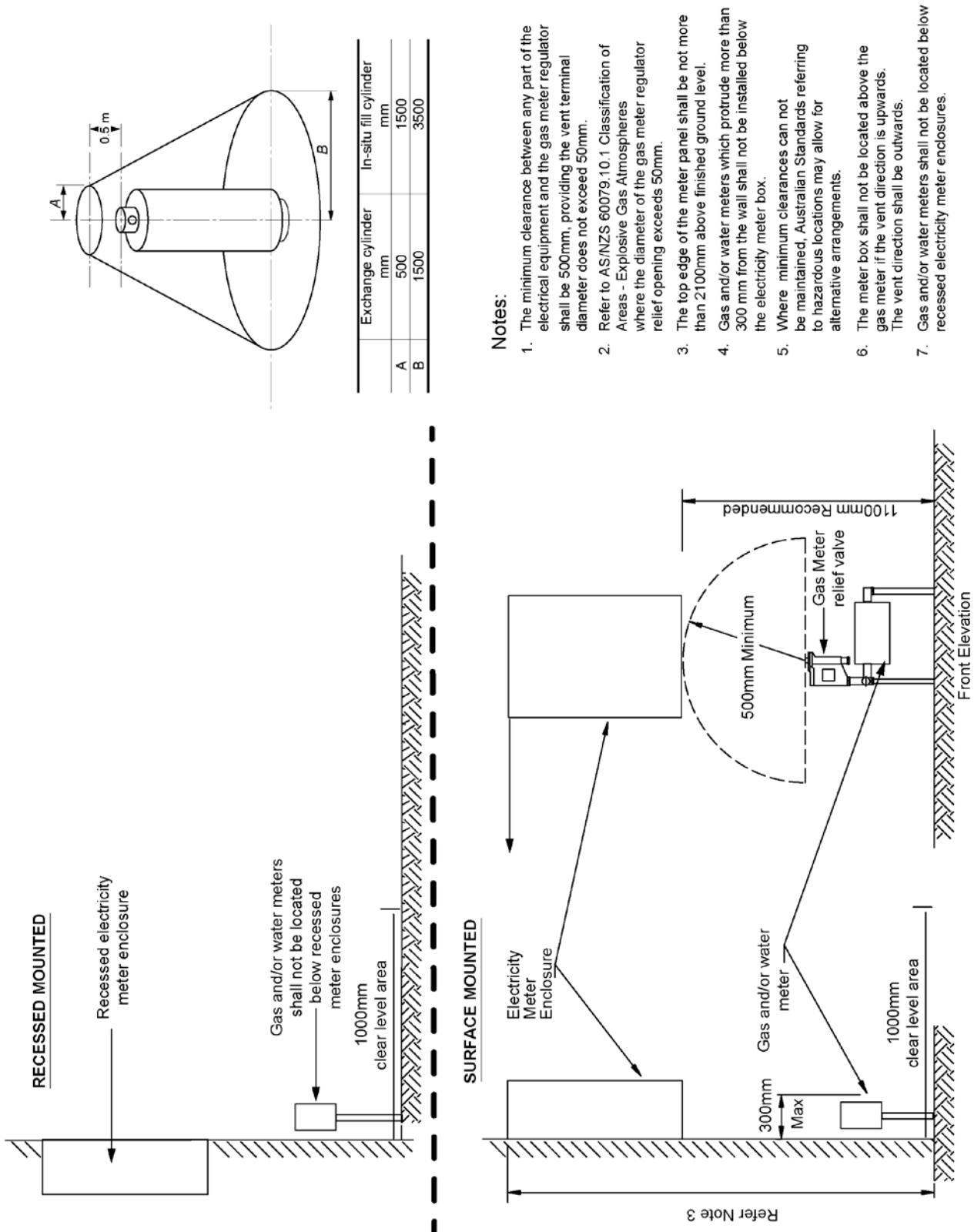

**Figure 8.10-D Meter Enclosure Near Gas and Water Meters & L.P.G. Exchangeable Gas Cylinders for Domestic Installations**

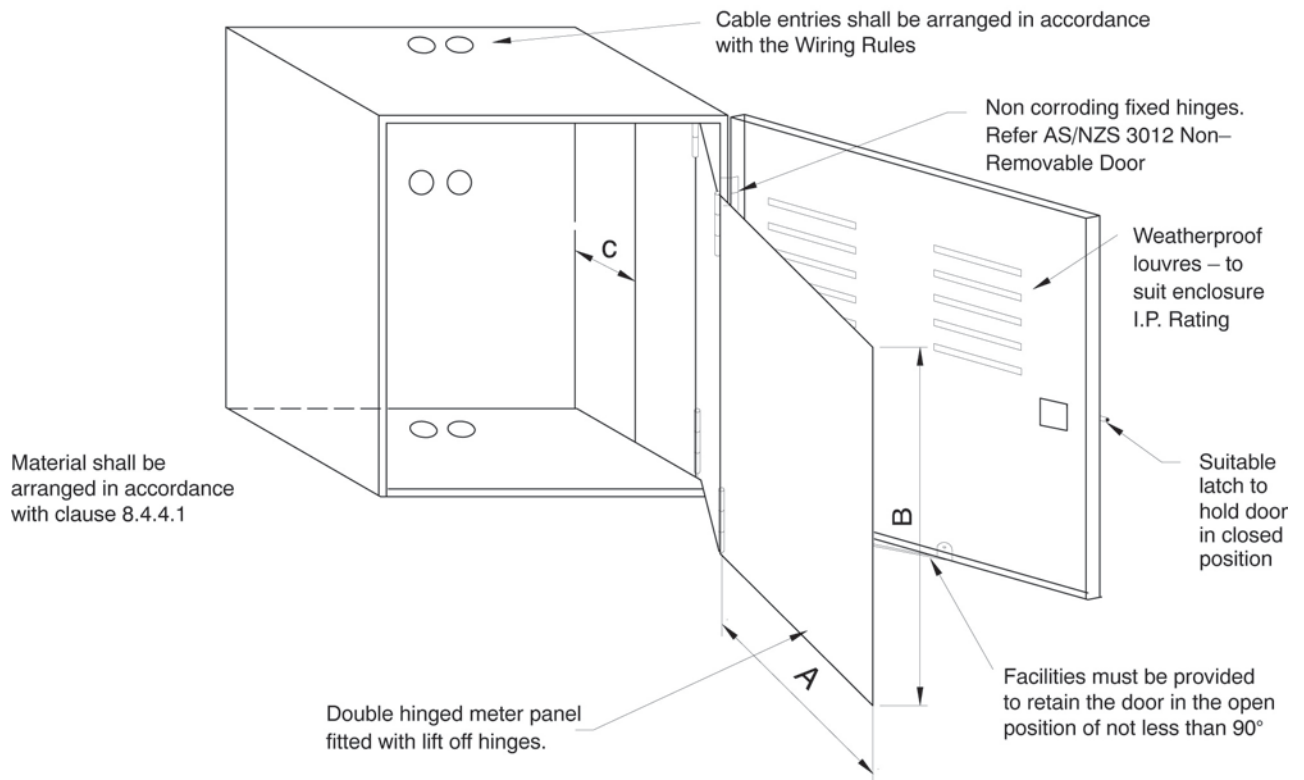

METER PANEL SIZE		INTERNAL DIMENSIONS	
'A'	'B'	Min. space in front of Meter Panel	Space Behind Meter Panel 'C'
400	380	---	In accordance with Table 8.9-1
400	590		
600	600		
600	900*	175	
CT Metering Only			
600	600		

\*Maximum size meter panel permitted 600x900mm + 10%

**NOTES:**

1. Suitable flashing may be required to prevent entry of moisture into enclosure if the enclosure is to be exposed to the weather. Particular attention should be given to the sealing around the door. The minimum degree of protection shall be IP23 as defined in AS 60529 and suitable for the environment as per the Wiring Rules. Adequate drain holes shall be provided in the bottom of the enclosure.
2. Meter Enclosure shall be constructed using galvanised sheet not less than 1.2mm thickness or other acceptable metal sheet
3. Refer to Clause 8.4.3.7 regarding the provisions for wiring not intended to be connected to the metering equipment.
4. The design and construction of non-commercially manufactured meter enclosures and panels shall be approved for use by the Responsible Officer.
5. Provision for sealing is required when panel is in the closed position.
6. Refer Clause 8.4.4 for further details regarding meter enclosure and panel requirements.
7. Provision for earthing shall be arranged in accordance with the Wiring Rules.
8. Refer to Clause 8.8.2 for further information on meter temperature limitations.

**Figure 8.10-E Meter Enclosure – Metal**

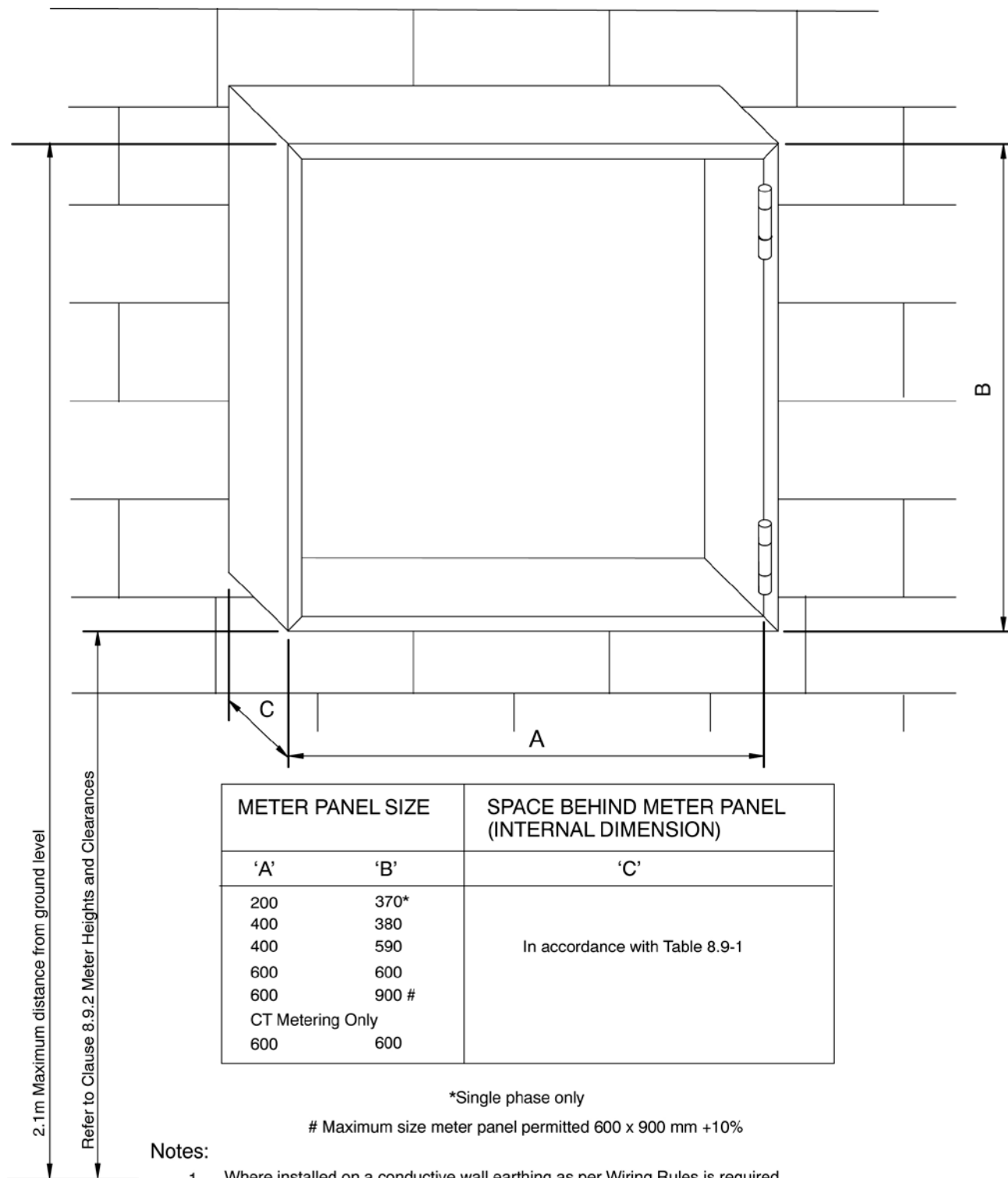

**Notes:**

1. Where installed on a conductive wall earthing as per Wiring Rules is required.
2. Where installed on a wall consisting combustible material, fire resistant lining shall be provided on the wall.
3. The customer shall provide the meter panel and and mounting surround. The meter panel shall be fire resistant, hinged and capable of being lifted off. Refer to Clause 8.4 for further details regarding meter panel surround and panel requirements.
4. Mounting surround constructed of galvanised sheet not less than 1.2mm thickness; or
  - other acceptable metal sheet; or
  - well seasoned timber lined with appropriate fire resistant material; or
  - other acceptable fire resistant material.

**Figure 8.10-F Typical Meter Panel Metal Mounting Surround**

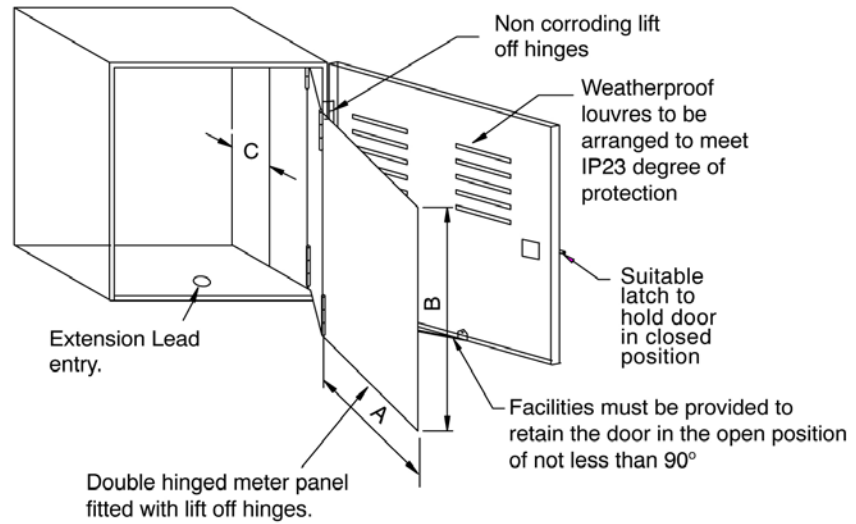

**ENCLOSURE DETAIL**

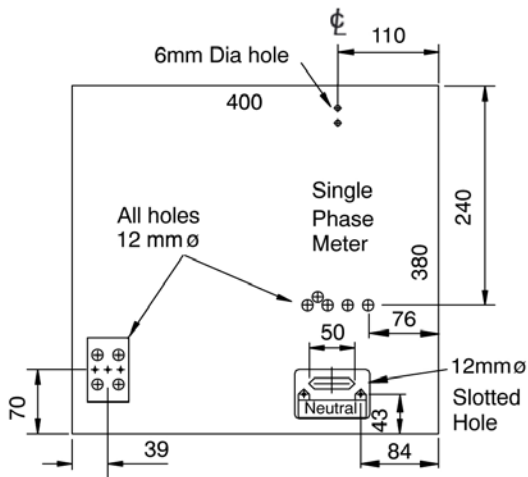

**METER PANEL LAYOUT**

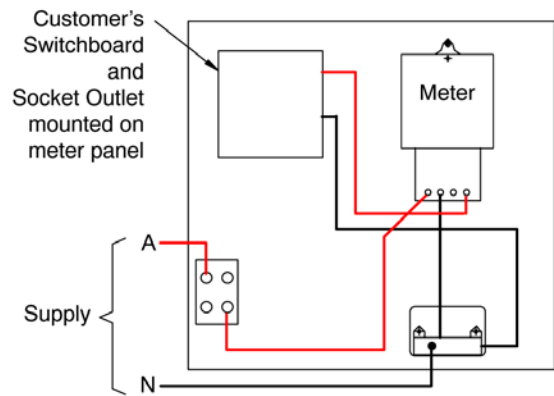

**WIRING DIAGRAM**

A2

Meter enclosure, panel, equipment and wiring shall be arranged in accordance with clauses 8.3 to 8.10.1.5.

Meter Panel Size		Internal Dimensions	
'A'	'B'	Space in front of panel	Space behind meter panel 'C'
400	380	175	As per Table 8.9-1

**Figure 8.10-G Typical Arrangement for Limited Period Supply Pole**

A1

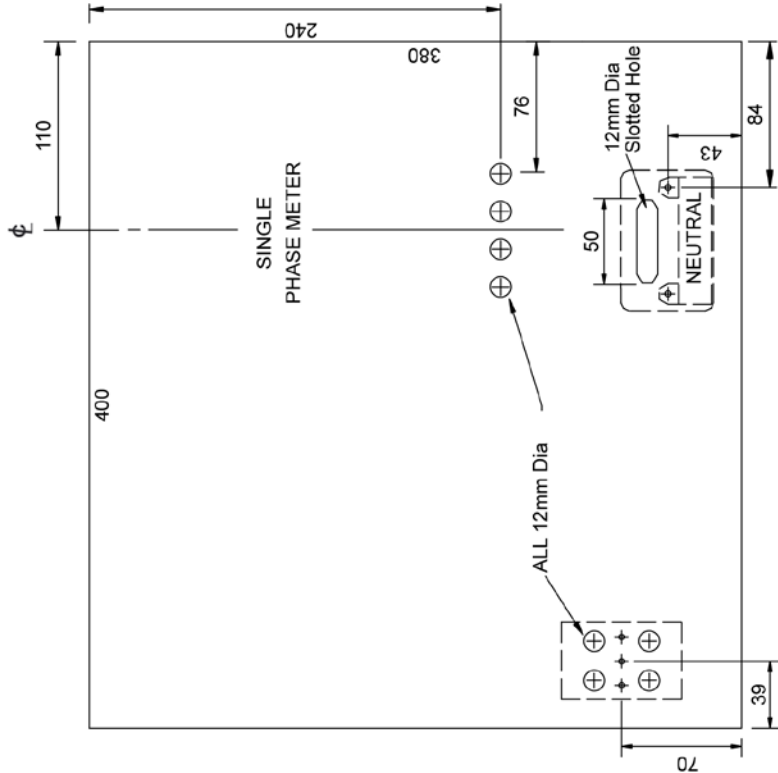

**Notes**

1. Meter panel fuse is required for underground supply areas only.
2. Refer to Fig 8.10-W for meter template.
3. Refer to Table 8.9-1 for conductor size limitations.
4. Meter Panel Wiring
  - Load carrying conductors not less than 4mm<sup>2</sup> or 6mm<sup>2</sup> or greater than 35mm<sup>2</sup>.
  - Meter neutral conductors shall be 4mm<sup>2</sup> or 6mm<sup>2</sup>
  - 25 & 35mm<sup>2</sup> conductors shall have not less than 18 strands
5. Permissible Off Peak Loads to be approved by the Distributor refer clause 8.2
6. Minimum size can be as per Table 8.10-1 for overhead areas where no fuse on the panel is required

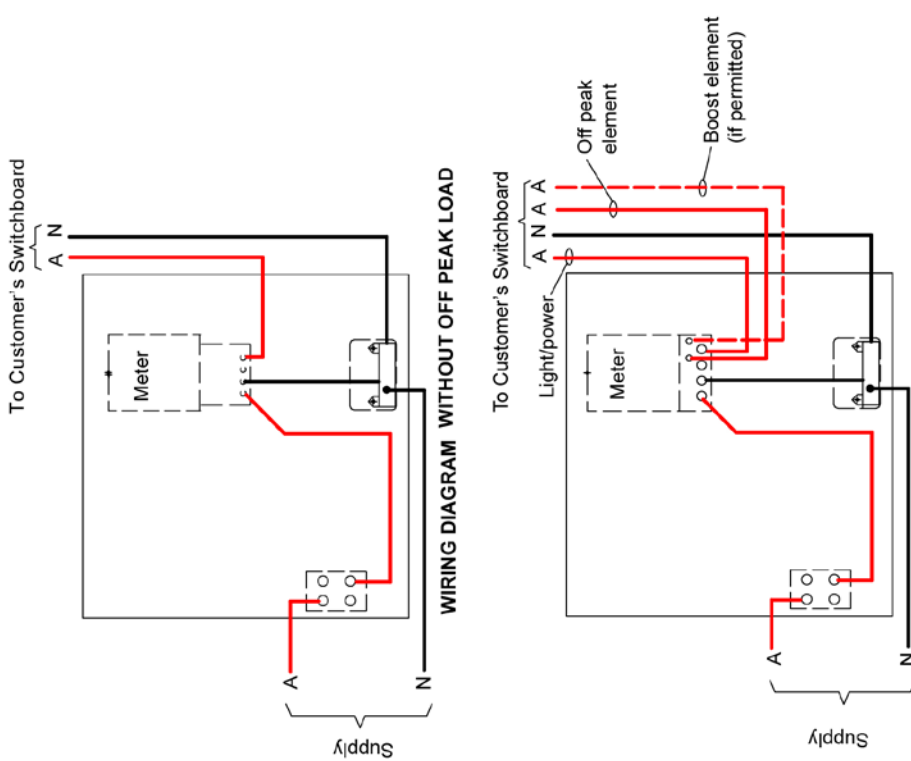

**Figure 8.10-H Typical Metering Details for One Customer Single Phase, With or Without Load Control, Panel Size 400 mm W x 380 mm H**



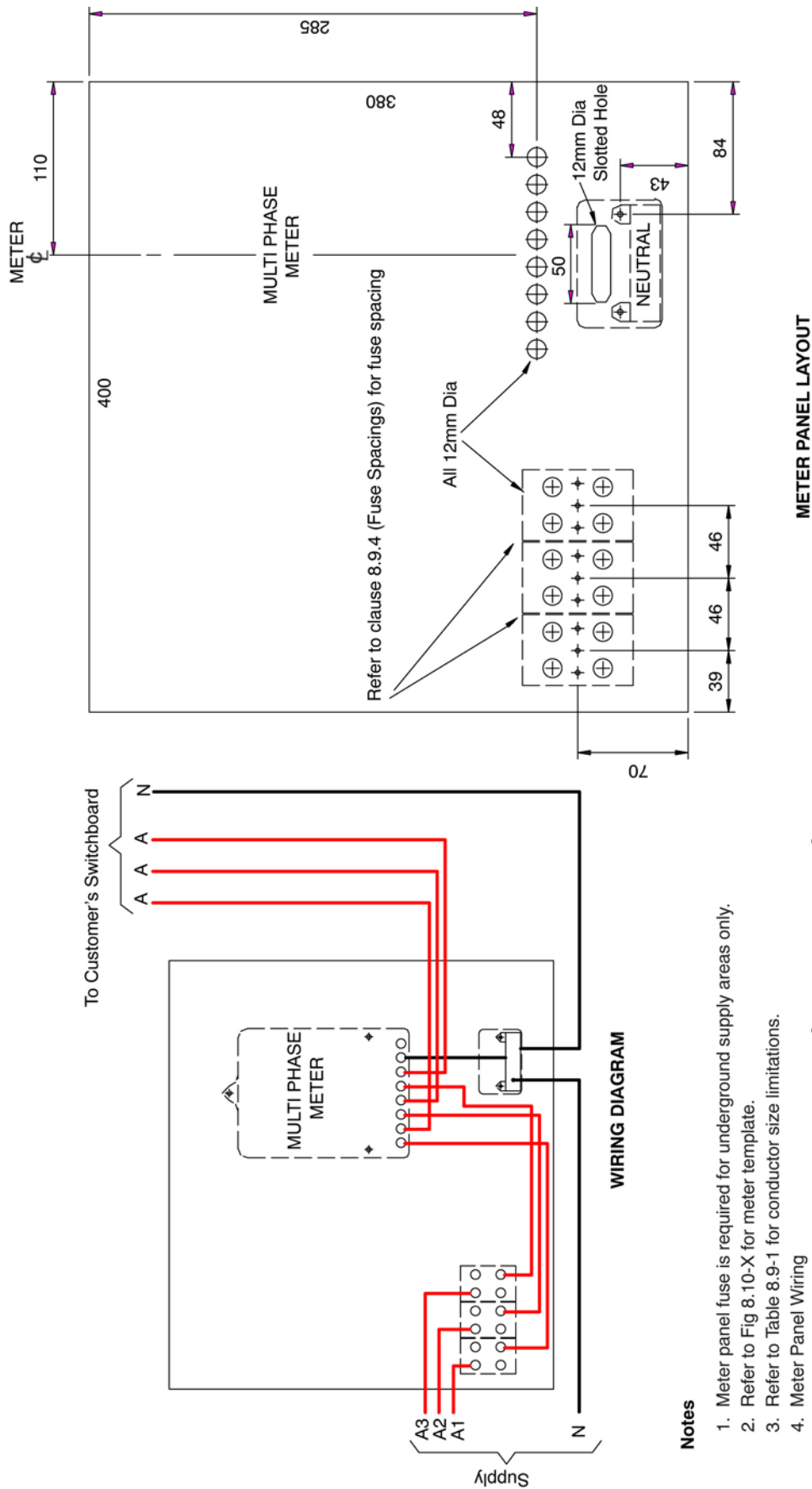

**Figure 8.10-I Typical Metering Details for One Customer Multi Phase Panel Size 400 mm W x 380 mm H**

## 8.10.2 Multiple Occupancy Buildings and Subdivisions (Metering Arrangements)

### 8.10.2.1 Plan

A plan shall be submitted to the Responsible Officer in accordance with Clause 7.10.2 for approval prior to finalisation of the electricity supply, distribution and metering arrangements of new multiple occupancy buildings or subdivisions. A similar plan shall be provided where additions or alterations to existing electrical installations within multiple occupancy buildings or subdivisions are intended. Failure to submit a plan in accordance with these Rules, prior to construction of the electrical installation, may result in unnecessary financial expense and substantial delay in order to rectify any discrepancies with these Rules and connection of the electricity supply.

### 8.10.2.3 Subdivisions Incorporating Common Property

The metering equipment, general distribution switchboards and the sub-mains installed for the purpose of supplying electricity to each of the lots, shall be placed within the common property.

### 8.10.2.4 Subdivisions Not Incorporating Common Property

### 8.10.2.5

Lots shown on a plan of subdivision, which does not incorporate common property, will be provided with a point of supply and individual meter position for each lot. For the purpose of establishing a single point of supply for each of the lots, all of the lots shown on the plan of subdivision shall abut a public road reserve.

### 8.10.2.6

The point of supply, consumer's terminals and metering equipment shall be arranged in accordance with clauses 6.2 (Point of Supply), 6.3 (Consumer's Terminals) and 8.10.1 (Single Occupancy).

### 8.10.2.7 Multiple Occupancy Buildings

The consumer's mains, metering equipment, general distribution switchboards and the sub-mains installed for the purpose of supplying electricity to each of the occupancies, shall be placed within the common area. Additional information related to the aforementioned wiring and equipment is provided in clauses 6.2 (Point of Supply), 6.3 (Consumer's terminals), 7.10 (Multiple Occupancy Buildings and Subdivisions) (Supply Arrangements)).

### 8.10.2.8 Possible Subdivision of Buildings or Land

The following information is intended to assist persons wishing to exercise an option to subdivide their property in the future. Where the subdivision of buildings or land is a possibility, it will be necessary for the property owner or developer to submit a draft plan of subdivision to the Distributor. The draft plan of subdivision is essential for the purpose of establishing an appropriate electricity metering arrangement and to avoid unnecessary future expense.

### 8.10.2.9 Grouping of Meters

Each individual lot or occupancy meter shall be grouped on common meter panels:

- with other occupancies meters;
- at a single location or a number of locations as determined by engineering considerations of supply;
- within common property, if the property contains common property; and
- in a position to which all occupants have common right of access.
- and shall not be located in an individual occupancy or single electrical installation either domestic or non domestic

Notwithstanding the above, the Responsible Officer may approve metering at individual locations on separate structures subject to specific conditions being met and maintained.

Where a greater number of meters are required than can be accommodated on a single panel, a suitable number of panels shall be grouped in a modular fashion.

**Table 8.10-2 Multiple Occupancy – Typical Meter Panel Sizes**

Maximum Number of Occupancy Meters per Panel			
Typical Meter Panel Size (mm) Width x Height	Single Phase, 2 Wire	Multi-phase	Combination Multi-phase and Single-phase
400 x 380	2	1	2 (provided the SPD's are not located on the meter panel)
400 x 590	4	2	2
600 x 600	6	3	3
600 x 900	9	4	Refer to Metering Provider

A1

**8.10.2.10 Labelling**

Each meter panel within multiple occupancies and subdivisions shall be labelled with the correct street address. Labels shall be displayed on the meter panel to indicate the relationship of meters, fuses and other equipment. Labels shall be in accordance with clause 5.4.

A1

A corresponding marking shall also be attached to the cables supplying each individual occupancy or lot at the rear of the meter panel.

Additional labelling of multiple occupancies shall be in accordance with clause 7.10.8 (Multiple Occupancies – Labelling).

**8.10.2.11 Meter Panel Isolation**

Each meter panel in a multiple occupancy building or subdivision shall be capable of being isolated by a single switch operating in all active conductors supplying that panel.

A switch is not required where only one panel is installed and it can be isolated by means other than a switch, eg, removal of Supply Protection Devices.

**8.10.2.11(a) Tenancy Isolation**

A3

All direct meters in a multiple occupancy shall have an individual tenancy isolators on the metered active conductors adjacent to the meter location. This requirement is also applicable where there are single customer meter panels within a multiple occupancy installation.

**8.10.2.12 Occupancy Disconnection Devices (ODD)**

**8.10.2.12 (a)** Notwithstanding clause 8.10.1.1, each meter associated with an occupancy or lot within a property shall be capable of being individually isolated by meter panel fuse/s (ODD) installed upon the same panel as the lot or occupancy meter. The fuse assembly shall be of a type similar to that described in clause 6.8.5.3.2 (b). The relevant Distributor will supply and install the fuse cartridge/s and seal the assemblies.

A2

**8.10.2.12 (b)** Meter Panel fuses installed as supply protection devices (SPD) on the same meter panel as the lot or occupancy meters; may be used for the purpose of isolating the individual lot or occupancy meters provided they are arranged so as only one meter is operated from any single SPD and the SPD can be sealed and/or locked off independently of each other. For example, 3 phase supply, 3 single phase SPD capable of being individually sealed and or locked with each SPD supplying a single phase lot or occupancy meter.

A3

Refer to Fig 8.10-M(b) for the requirements for a four customer meter panel

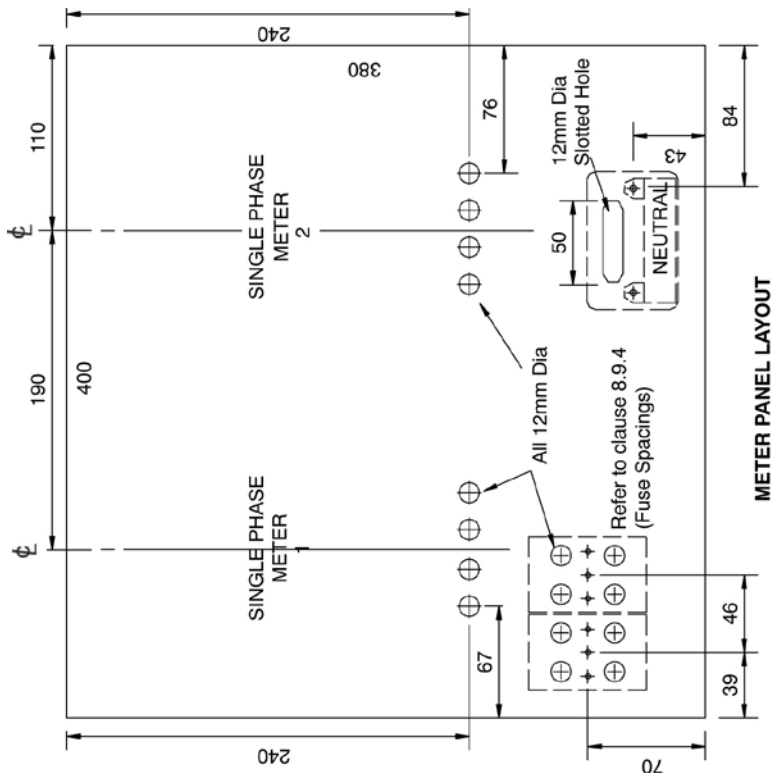

**Notes**

1. Meter panel fuses (ODD) are required for each customer in overhead and underground supply areas.
2. Refer to Fig 8.10-W for meter template.
3. Refer to Table 8.9-1 for conductor size limitations.
4. Meter Panel Wiring
  - Load carrying conductors not less than 4mm<sup>2</sup> or greater than 35mm<sup>2</sup>.
  - Meter neutral conductors shall be 4mm<sup>2</sup> or 6mm<sup>2</sup>
  - 25 & 35mm<sup>2</sup> conductors shall have not less than 18 strands
5. Permissible Off Peak Loads to be approved by the Distributor, refer clause 8.2.
6. SPD to be provided in accordance with Tables 7.2-1, 7.3-2, 7.4-3 or 7.5-1 whichever is applicable. .

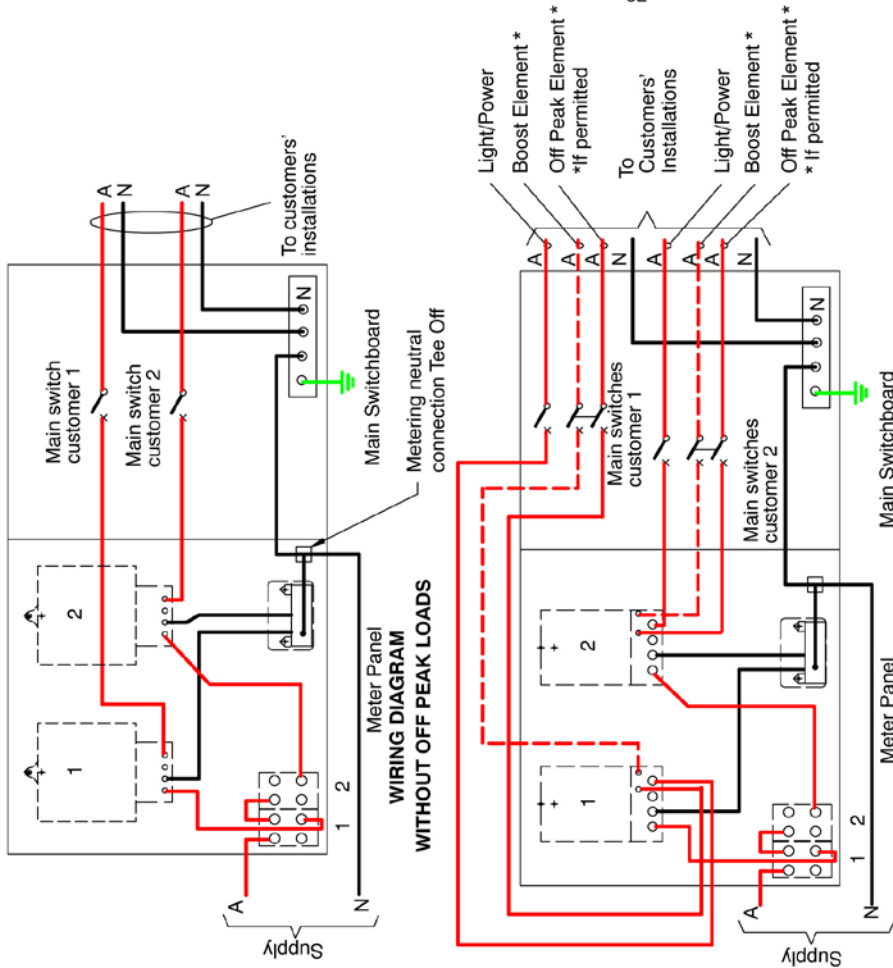

**Figure 8.10-J Typical Metering Details for Two Customers, Single Phase, With or Without Load Control, Panel Size 400 mm W x 380 mm H**

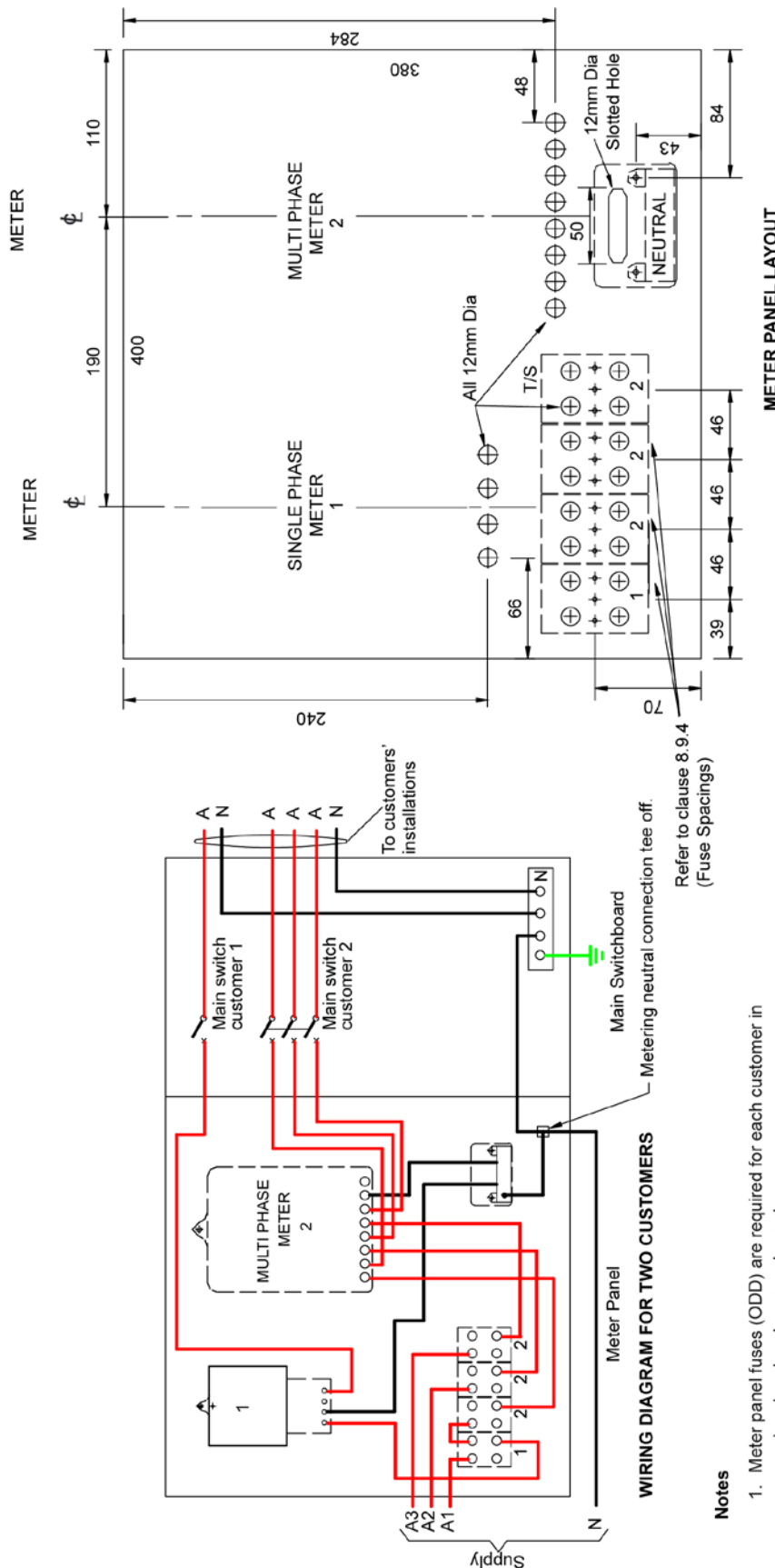

**Figure 8.10-K Typical Metering Details for Two Customers, 1 – Multiphase Meter, 1 – Single Phase Meter, Panel Size 400 mm W x 380 mm H**

**Notes**

1. Meter panel fuses (ODD) are required for each customer in overhead and underground supply areas.
2. Refer to Fig 8.10-W and 8.10-X for meter template.
3. Refer to Table 8.9-1 for conductor size limitations.
4. Where a constant 3 phase load in excess of 50A per phase is expected, the meter panel fuses shall be spaced not less than 20mm apart. In some cases, to accommodate this spacing, a larger meter panel may be necessary.
5. Meter Panel Wiring
  - Load carrying conductors not less than 4mm<sup>2</sup> or greater than 35mm<sup>2</sup>
  - Meter neutral conductors shall be 4mm<sup>2</sup> or 6mm<sup>2</sup>
  - 25 & 35mm<sup>2</sup> conductors shall have not less than 18 strands
6. SPD to be provided in accordance with Tables 7.2-1, 7.3-2, 7.4-3 or 7.5-1 which ever is applicable.

A1

A1

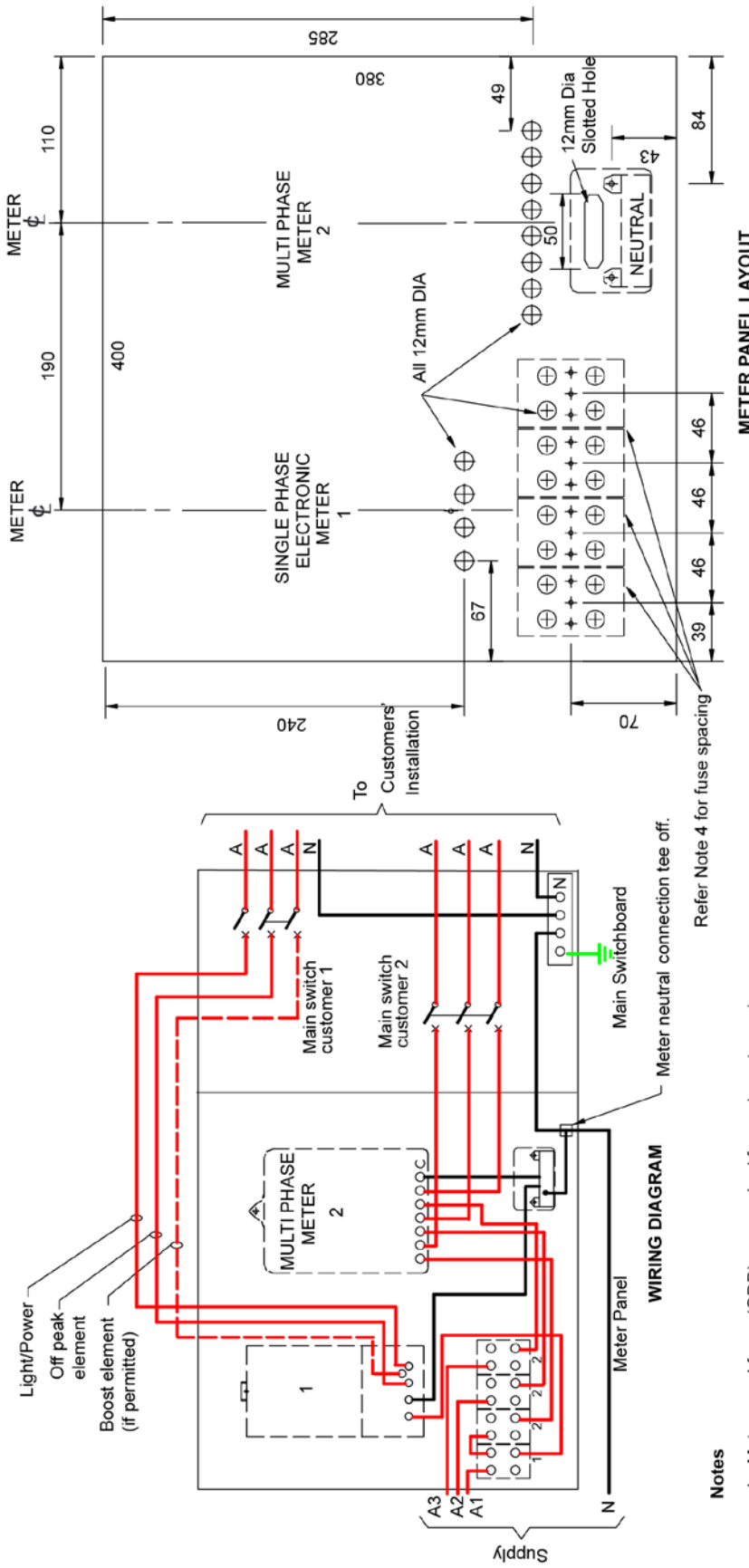
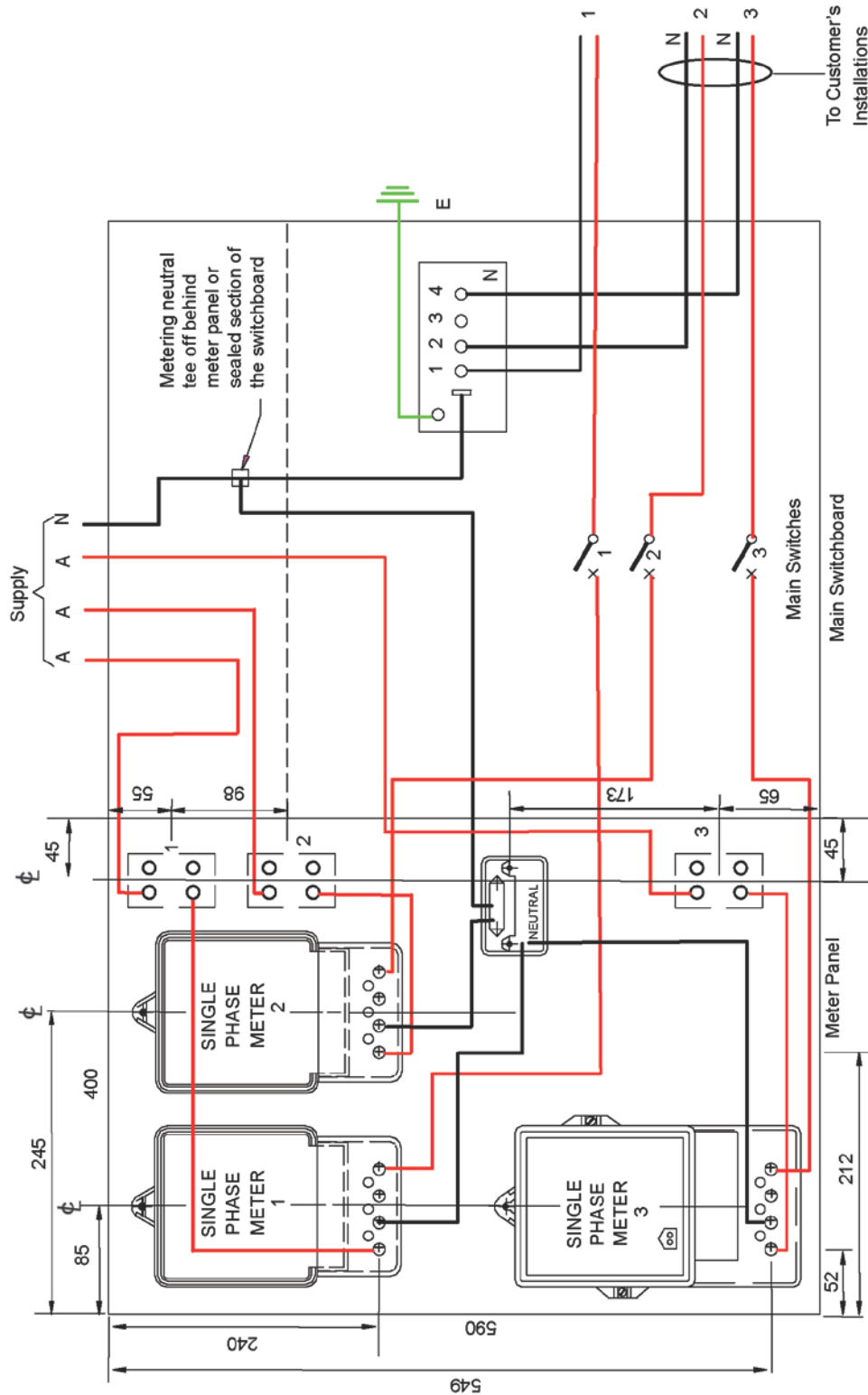

**Figure 8.10-L Typical Metering Details for Two Customers, 1 – Multiphase Meter, 1 – Single Phase Meter with load control, Panel Size 400 mm W x 380 mm H**

**Notes**

1. Meter panel fuses (ODD) are required for each customer in overhead and underground supply areas.
2. Refer to Fig 8.10-W and 8.10-X for meter template.
3. Refer to Table 8.9-1 for conductor size limitations.
4. Where a constant 3 phase load in excess of 50A per phase is expected, the meter panel fuses shall be spaced not less than 20mm apart.  
In some cases, to accommodate this spacing, a larger meter panel may be necessary.
5. Meter Panel Wiring
  - Load carrying conductors not less than 4mm<sup>2</sup> or greater than 35mm<sup>2</sup>
  - Meter neutral conductors shall be 4mm<sup>2</sup> or 6mm<sup>2</sup>
  - 25 & 35mm<sup>2</sup> conductors shall have not less than 18 strands
6. SPD to be provided in accordance with Tables 7.2-1, 7.3-2, 7.4-3 or 7.5-1 which ever is applicable.
7. Permissible Off Peak Loads to be approved by the Distributor, refer clause 8.2

A3



**Notes:**

1. Meter panel fuses (ODD) are required for each customer in overhead and underground supply areas.
2. Refer to Fig 8.10-W for meter template.
3. Refer to Table 8.9-1 for conductor size limitations.
4. Meter Panel Wiring
  - Load carrying conductors not less than 4mm<sup>2</sup> or greater than 35mm<sup>2</sup>
  - Meter neutral conductors shall be 4mm<sup>2</sup> or 6mm<sup>2</sup>
  - 25 & 35mm<sup>2</sup> conductors shall have not less than 18 strands
5. Permissible Off Peak Loads to be approved by the Distributor, refer clause 8.2
6. Refer to Fig 8.10-M(b) for a four customer meter panel

A2

**Figure 8.10-M(a) Typical Metering Details for Three Customers Single Phase With or Without Load Control**

A2

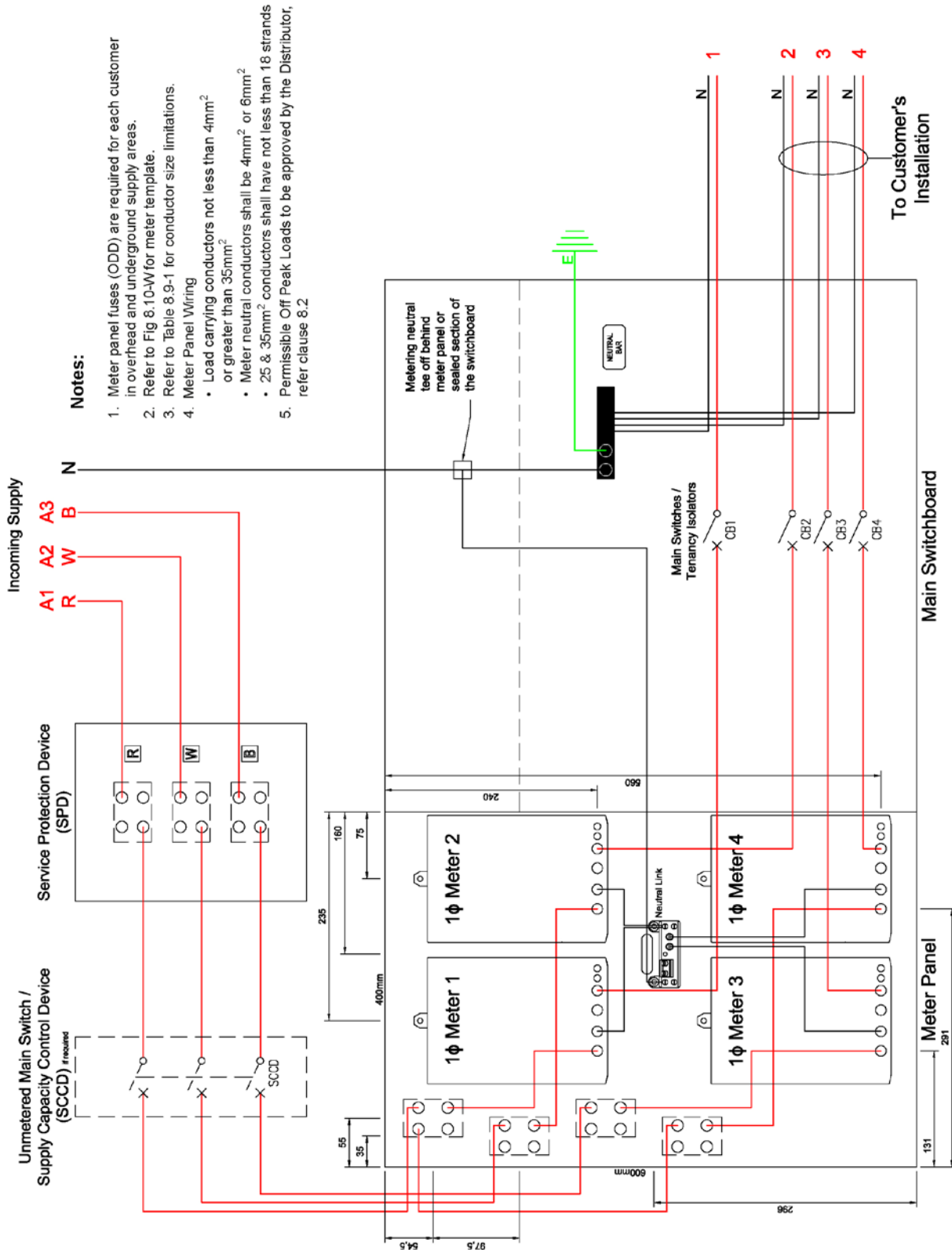

**Notes:**

1. Meter panel fuses (ODD) are required for each customer in overhead and underground supply areas.
2. Refer to Fig 8.10-W for meter template.
3. Refer to Table 8.9-1 for conductor size limitations.
4. Meter Panel Wiring
  - Load carrying conductors not less than 4mm<sup>2</sup> or greater than 35mm<sup>2</sup>
  - Meter neutral conductors shall be 4mm<sup>2</sup> or 6mm<sup>2</sup>
  - 25 & 35mm<sup>2</sup> conductors shall have not less than 18 strands
5. Permissible Off Peak Loads to be approved by the Distributor, refer clause 8.2

**Figure 8.10-M-(b) Typical Metering Details for Four Customers Single Phase, With or Without Load Control and With or Without SCCD**



**This page intentionally blank**

A2

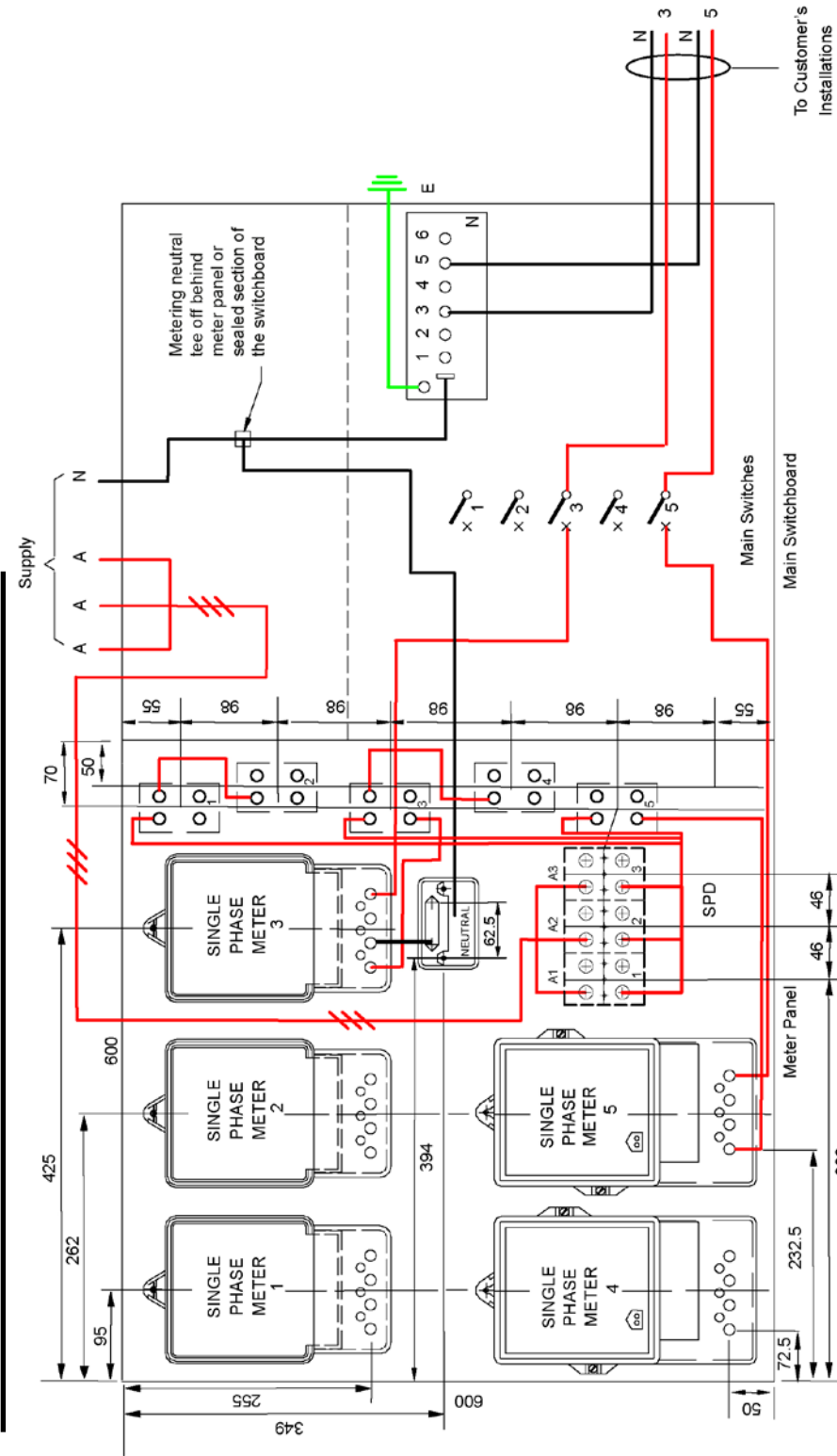

**Notes:**

1. For simplicity wiring shown only for customer 3 & 5.
2. Meter panel fuses (ODD) are required for each customer in overhead and underground supply areas.
3. Refer to Fig 8.10-W for meter template.
4. Refer to Table 8.9-1 for conductor size limitations.
5. Meter Panel Wiring
  - Load carrying conductors not less than 4mm<sup>2</sup> or greater than 35mm<sup>2</sup>
  - Meter neutral conductors shall be 4mm<sup>2</sup> or 6mm<sup>2</sup>
  - 25 & 35mm<sup>2</sup> conductors shall have not less than 18 strands
6. For six customers the neutral link shall be located at the rear of the panel and the SPD shall be provided in accordance with Tables 7.2-1, 7.3-2, 7.4-3 or 7.5-1 which ever is applicable.
7. Where a constant 3 phase load in excess of 50 amps per phase is expected, the meter panel fuses shall be spaced not less than 20mm apart.

**Figure 8.10-N Typical Meter Details – 5 Customers all Single Phase. Panel Size 600 mm W x 600 mm H**

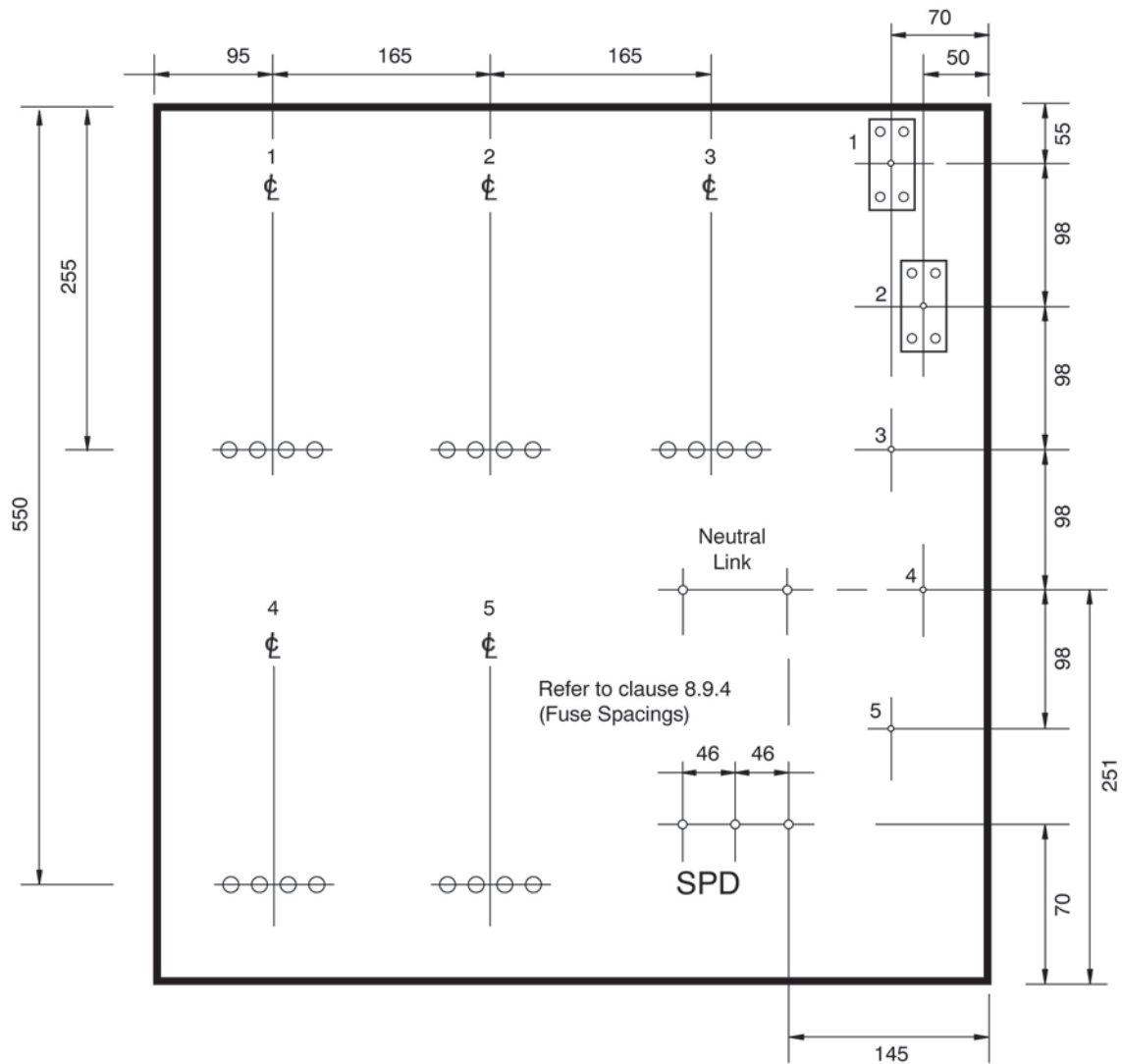
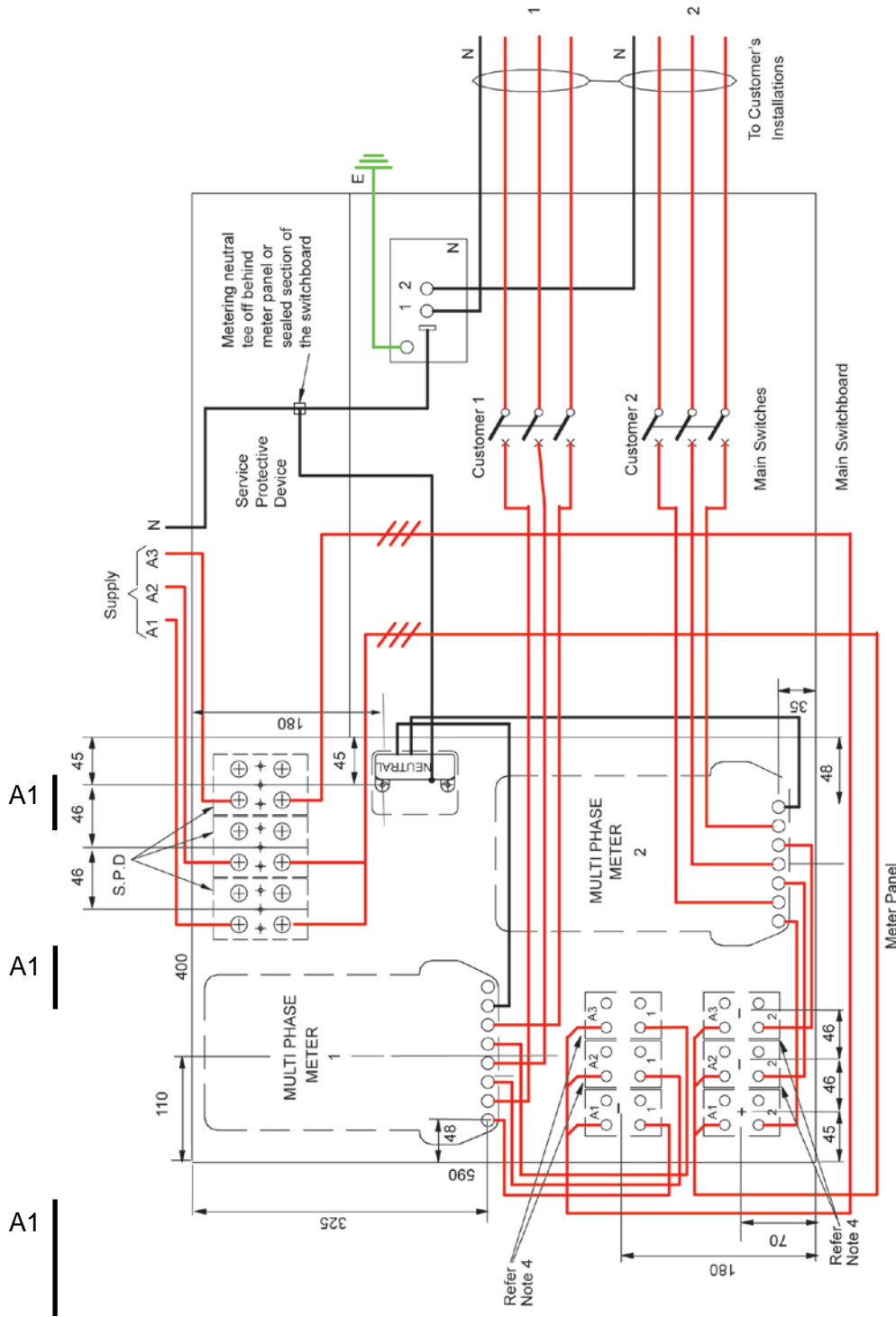

Figure 8.10-O Typical Meter Panel Drilling Template for Figure 8.10-N



**Notes:**

1. Meter panel fuses (ODD) are required for each customer in overhead and underground supply areas.
2. Refer to Fig 8.10-X for meter template.
3. Refer to Table 8.9-1 for conductor size limitations.
4. Where a constant 3 phase load in excess of 50A per phase is expected, the meter panel fuses shall be spaced not less than 20mm apart.  
In some cases, to accommodate this spacing, a larger meter panel may be necessary.
5. Meter Panel Wiring
  - Load carrying conductors not less than 4mm<sup>2</sup> or greater than 35mm<sup>2</sup>
  - Meter neutral conductors shall be 4mm<sup>2</sup> or 6mm<sup>2</sup>
  - 25 & 35mm<sup>2</sup> conductors shall have not less than 18 strands
6. SPD to be provided in accordance with Tables 7.2-1, 7.3-2, 7.4-3 or 7.5-1 which ever is applicable.

**Figure 8.10-P Typical Metering Arrangement for Two Customers  
2 – Multiphase  
Panel Size 400 mm W x 590 mm H  
Complete with Supply Protection Devices**

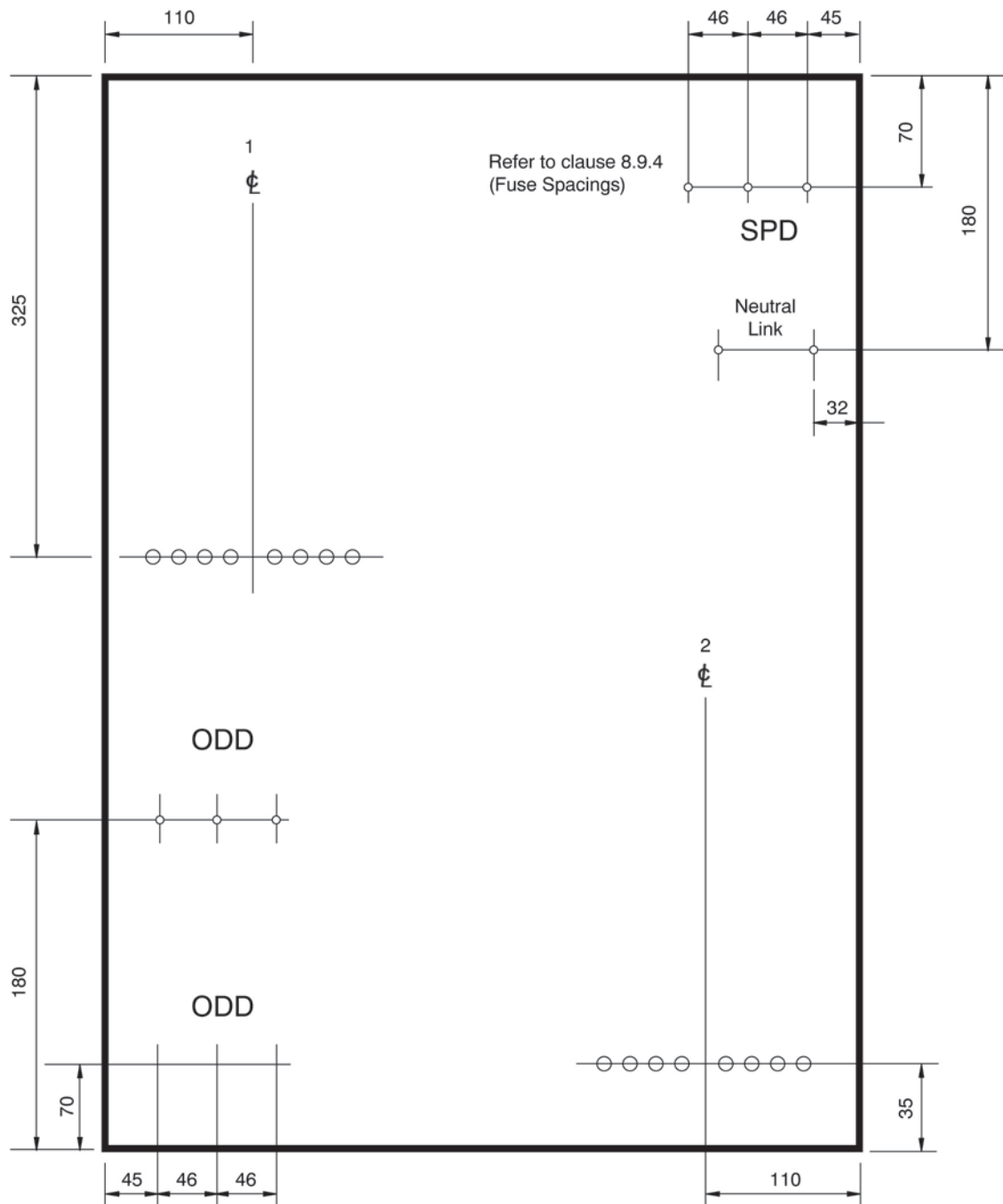
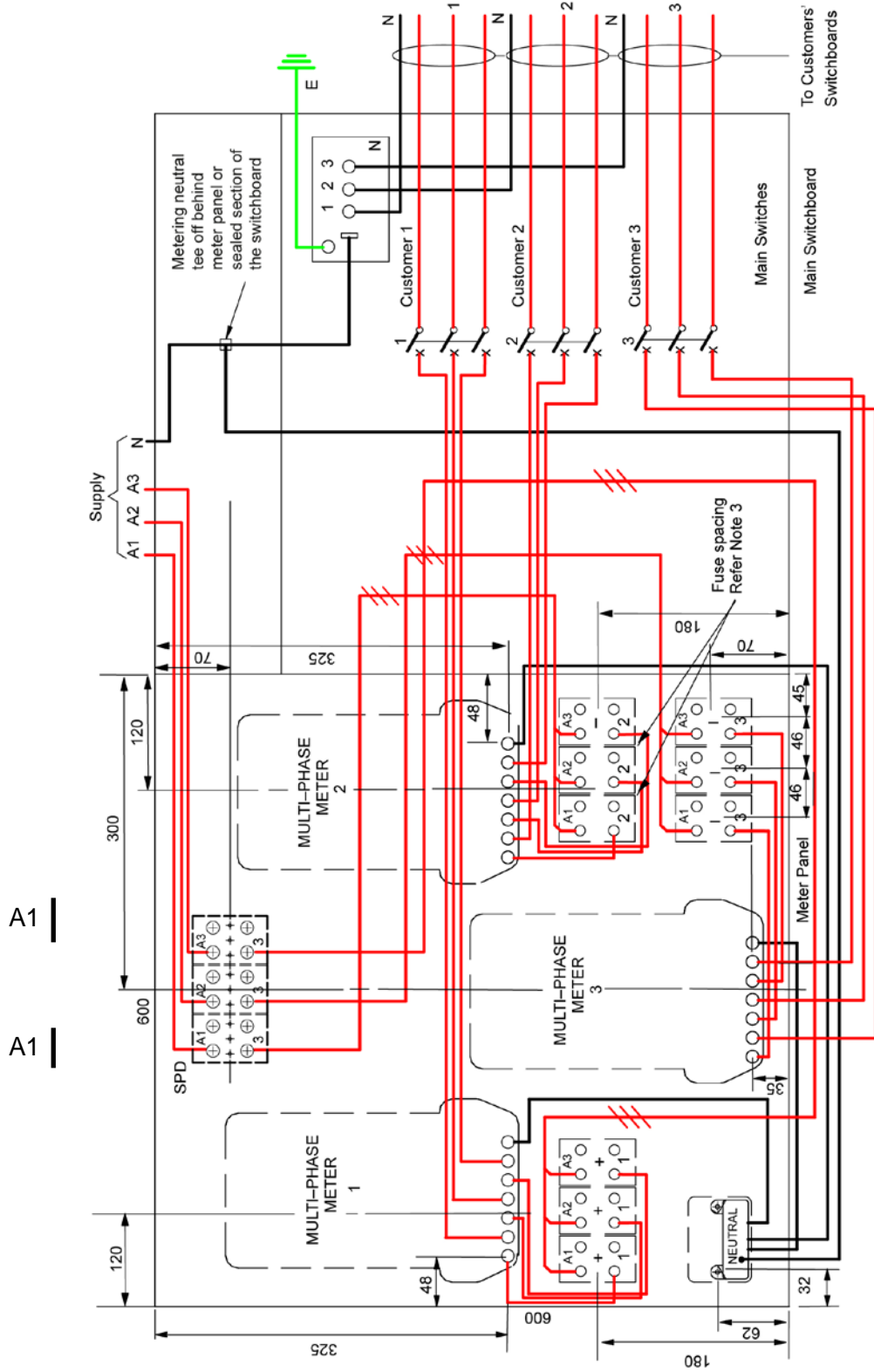
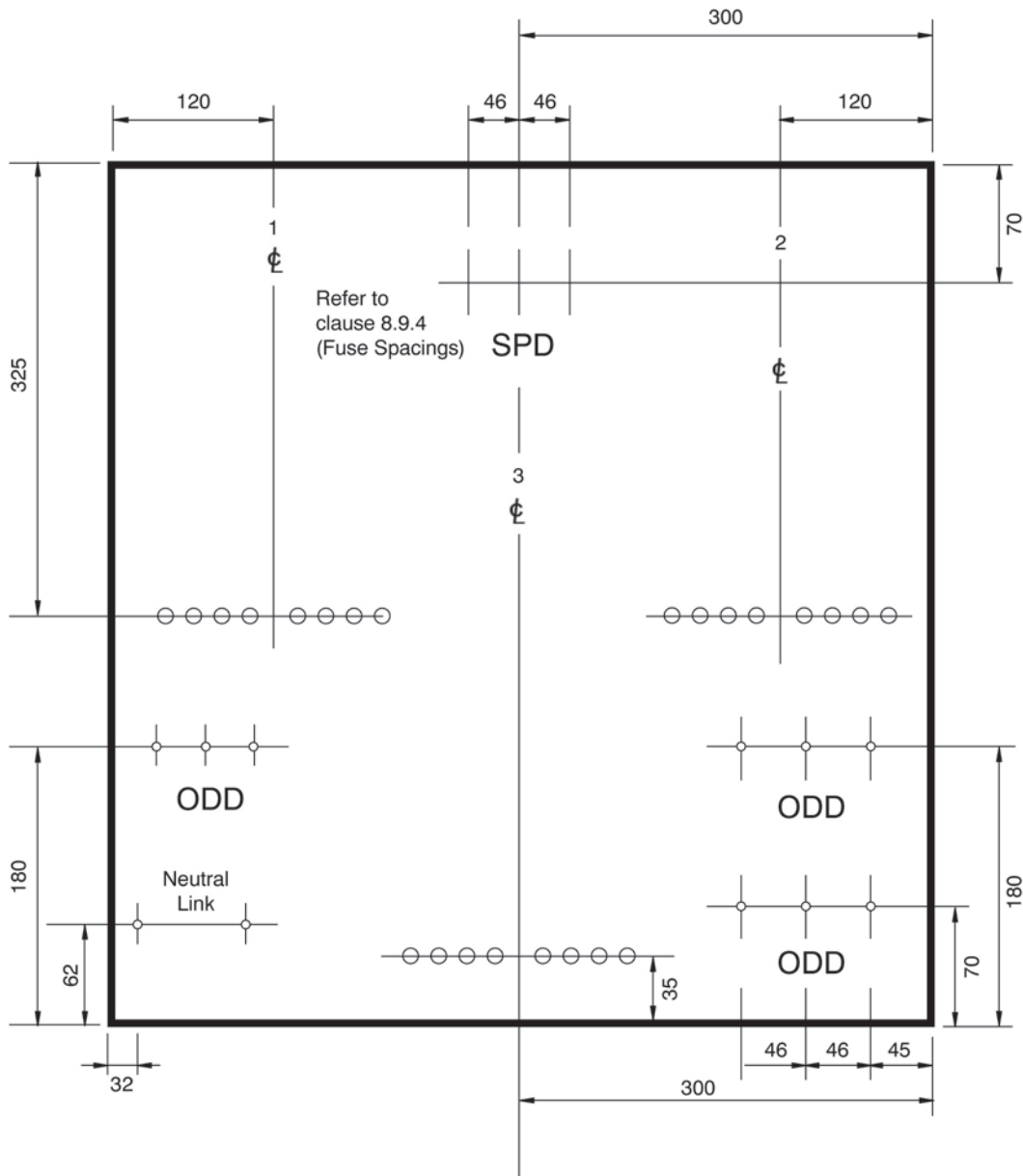

Figure 8.10-Q Typical Meter Panel Drilling Template for Figure 8.10-P



- Notes**
1. Meter panel fuses (ODD) are required for each customer in overhead and underground supply areas.
  2. Refer to Fig 8.10-X for meter template.
  3. Refer to Table 8.9-1 for conductor size limitations.
  4. Where a constant 3 phase load in excess of 50A per phase is expected, the meter panel fuses shall be spaced not less than 20mm apart. In some cases, to accommodate this spacing, a larger meter panel may be necessary.
  5. Meter Panel Wiring
    - Load carrying conductors not less than 4mm<sup>2</sup> or greater than 35mm<sup>2</sup>
    - Meter neutral conductors shall be 4mm<sup>2</sup> or 6mm<sup>2</sup>
    - 25 & 35mm<sup>2</sup> conductors shall have not less than 18 strands
  6. SPD to be provided in accordance with Tables 7.2-1, 7.3-2, 7.4-3 or 7.5-1 which ever is applicable.

**Figure 8.10-R Typical Metering Arrangement for Three Customers  
3 – Multiphase Panel Size 600 mm W x 600 mm H  
Complete with Supply Protection Devices**



**Figure 8.10-S Typical Meter Panel Drilling Template for Figure 8.10-R**

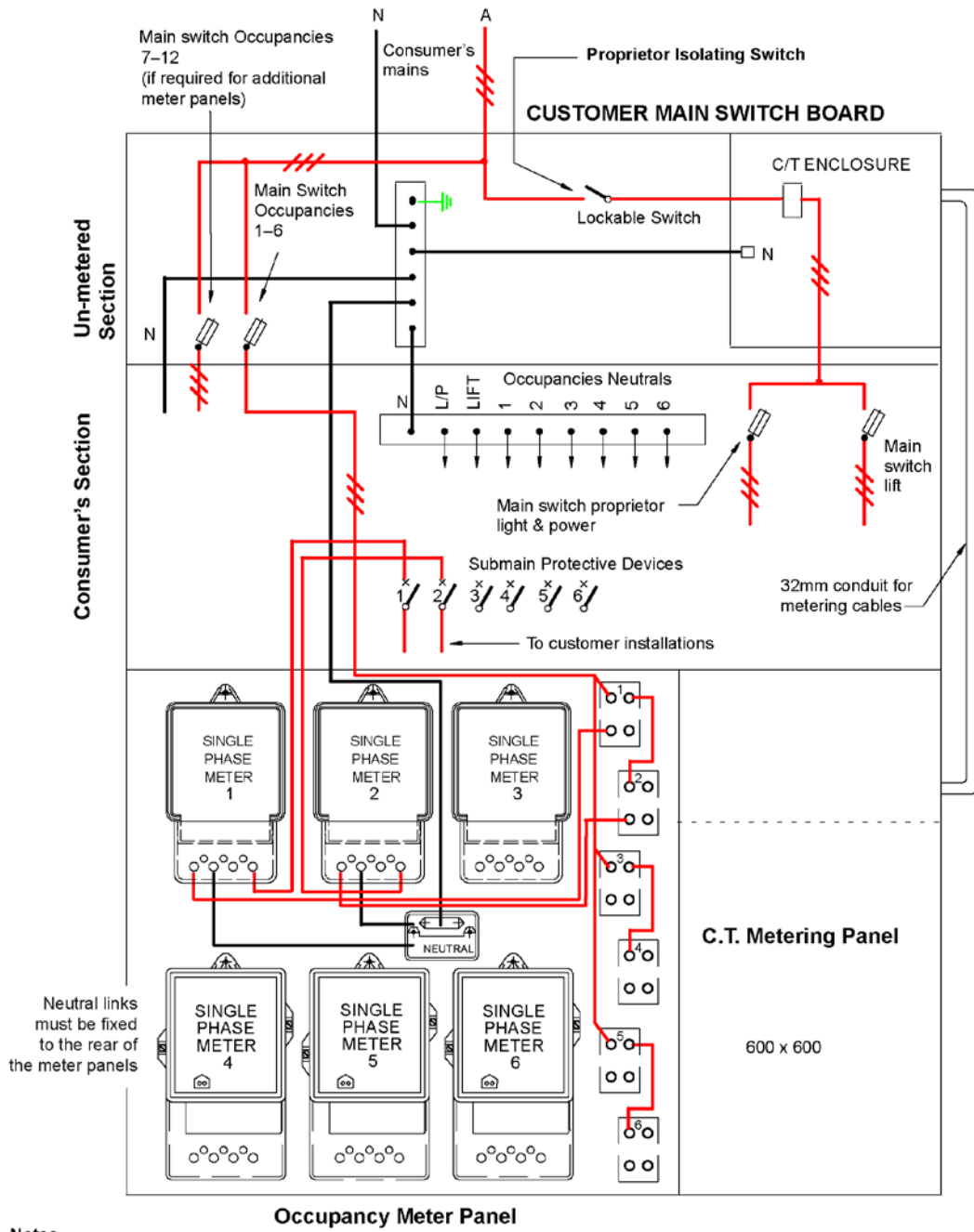

**Notes**

1. A plan of the installation showing the location of the metered and un-metered Mains and sub-mains in relation to the main structural features, together with a schematic diagram indicating the control, isolation and metering arrangements of the installation, shall be submitted to the Responsible Officer for approval prior to the intended commencement of the installation.
2. For simplicity wiring shown only for occupancies 1 & 2.
3. Attention to Wiring Rules regarding switches controlling Safety services is recommended.
4. Meter panel fuses (ODD) are required for each customer in overhead and underground supply areas.
5. Refer to Fig 8.10-W for meter template.
6. Refer to Table 8.9-1 for conductor size limitations.
7. Where a constant 3 phase load in excess of 50A per phase is expected, the meter panel fuses shall be spaced not less than 20mm apart. In some cases, to accommodate this spacing, a larger meter panel may be necessary.
8. Meter Panel Wiring
  - Load carrying conductors not less than 4mm<sup>2</sup> or greater than 35mm<sup>2</sup>
  - Meter neutral conductors shall be 4mm<sup>2</sup> or 6mm<sup>2</sup>
  - 25 & 35mm<sup>2</sup> conductors shall have not less than 18 strands
9. For six customers the neutral link shall be located at the rear of the panel and the SPD shall be provided in accordance with Tables 7.2-1, 7.3-2, 7.4-3 or 7.5-1 which ever is applicable.

**Figure 8.10-T Typical Wiring Diagram for Separately Metered Occupancies Including CT Metering for Proprietor**

A1

A2



A2

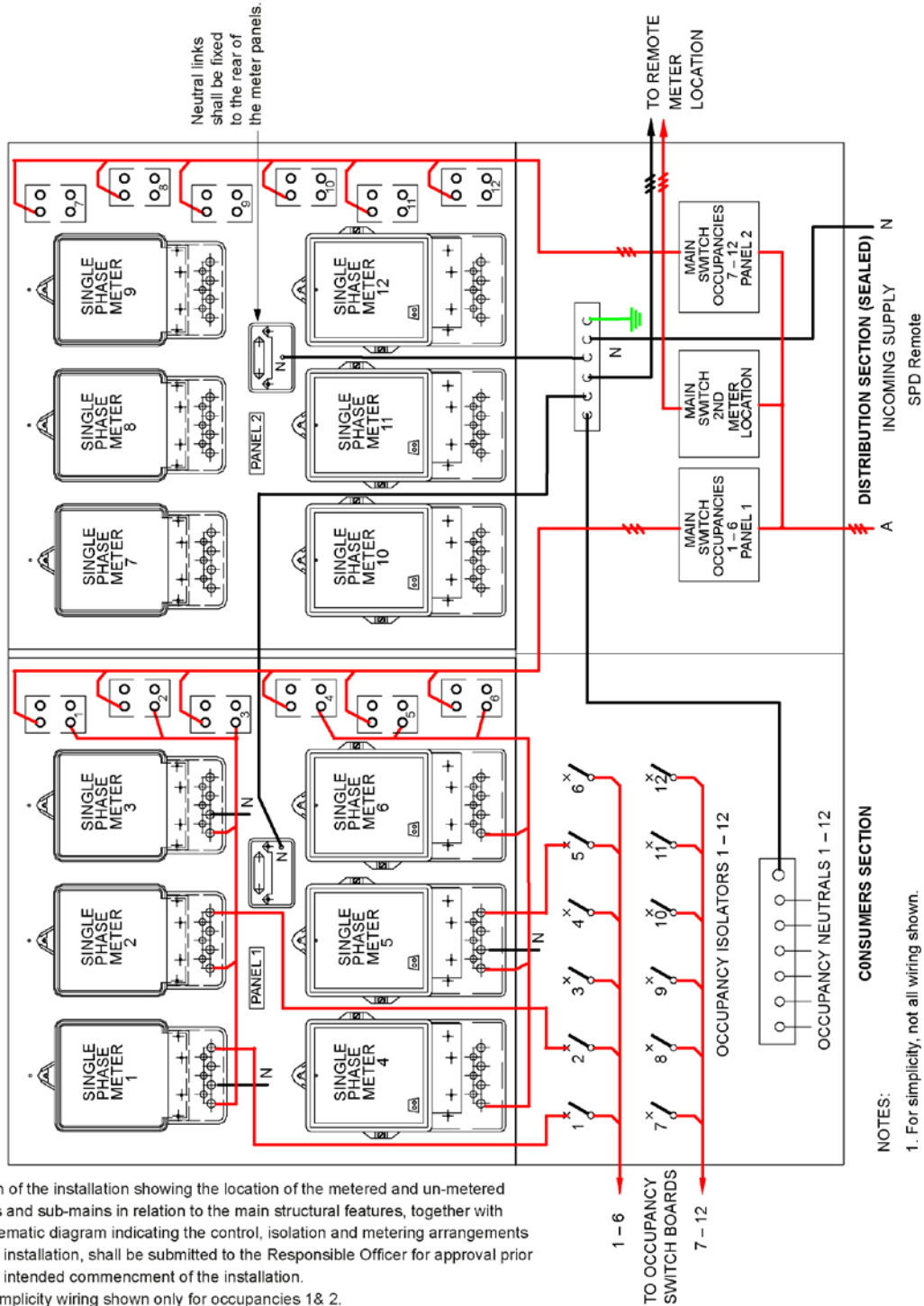

**Notes**

1. A plan of the installation showing the location of the metered and un-metered Mains and sub-mains in relation to the main structural features, together with a schematic diagram indicating the control, isolation and metering arrangements of the installation, shall be submitted to the Responsible Officer for approval prior to the intended commencement of the installation.
2. For simplicity wiring shown only for occupancies 1 & 2.
3. Attention to Wiring Rules regarding switches controlling Safety services is recommended.
4. Meter panel fuses (ODD) are required for each customer in overhead and underground supply areas.
5. Refer to Fig 8.10-W for meter template.
6. Refer to Table 8.9-1 for conductor size limitations.
7. Where a constant 3 phase load in excess of 50A per phase is expected, the meter panel fuses shall be spaced not less than 20mm apart. In some cases, to accommodate this spacing, a larger meter panel may be necessary.
8. Meter Panel Wiring
  - Load carrying conductors not less than 4mm<sup>2</sup> or greater than 35mm<sup>2</sup>
  - Meter neutral conductors shall be 4mm<sup>2</sup> or 6mm<sup>2</sup>
  - 25 & 35mm<sup>2</sup> conductors shall have not less than 18 strands
9. For six customers the neutral link shall be located at the rear of the panel and the SPD shall be provided in accordance with Tables 7.2-1, 7.3-2, 7.4-3 or 7.5-1 which ever is applicable.

**NOTES:**

1. For simplicity, not all wiring shown.
2. Metering neutrals minimum 4mm<sup>2</sup> stranded conductors.

A1

A2

**Figure 8.10-U Typical Arrangements of Main Switchboard and Metering for 12 Occupancies**

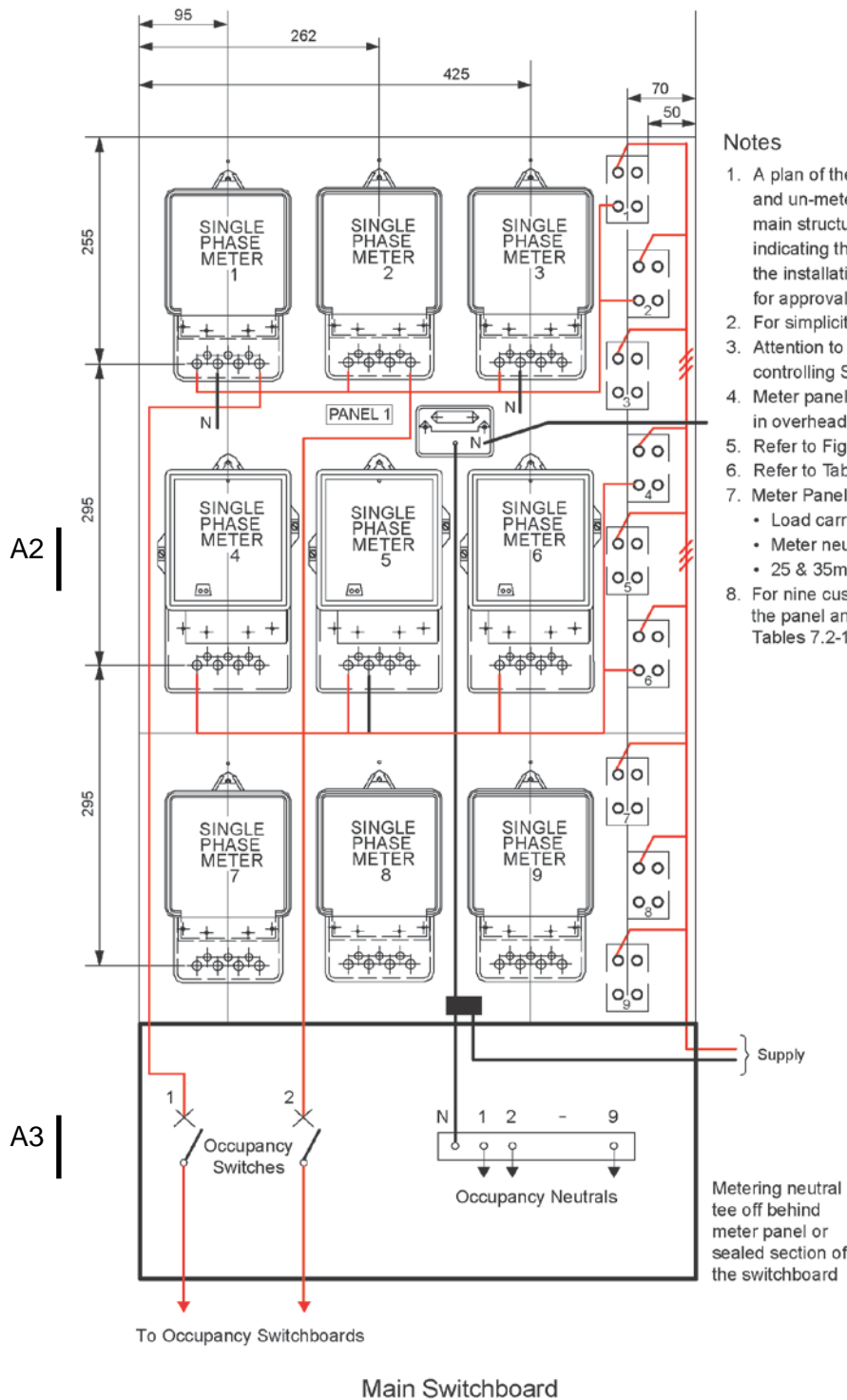

Notes

1. A plan of the installation showing the location of the metered and un-metered Mains and sub-mains in relation to the main structural features, together with a schematic diagram indicating the control, isolation and metering arrangements of the installation shall be submitted to the Responsible Officer for approval prior to the intended commencement of the installation.
2. For simplicity wiring shown only for occupancies 1 & 2.
3. Attention to Wiring Rules regarding switches controlling Safety services is recommended.
4. Meter panel fuses (ODD) are required for each customer in overhead and underground supply areas.
5. Refer to Fig 8.10-W for meter template.
6. Refer to Table 8.9-1 for conductor size limitations.
7. Meter Panel Wiring
  - Load carrying conductors not less than 4mm<sup>2</sup> or greater than 35mm<sup>2</sup>
  - Meter neutral conductors shall be 4mm<sup>2</sup> or 6mm<sup>2</sup>
  - 25 & 35mm<sup>2</sup> conductors shall have not less than 18 strands
8. For nine customers the neutral link shall be located at the rear of the panel and the SPD shall be provided in accordance with Tables 7.2-1, 7.3-2, 7.4-3 or 7.5-1 which ever is applicable.

**Figure 8.10-V Typical Meter and Switchboard Arrangements for 9 Customers all Single Phase. Panel Size 600 mm X 900mm**

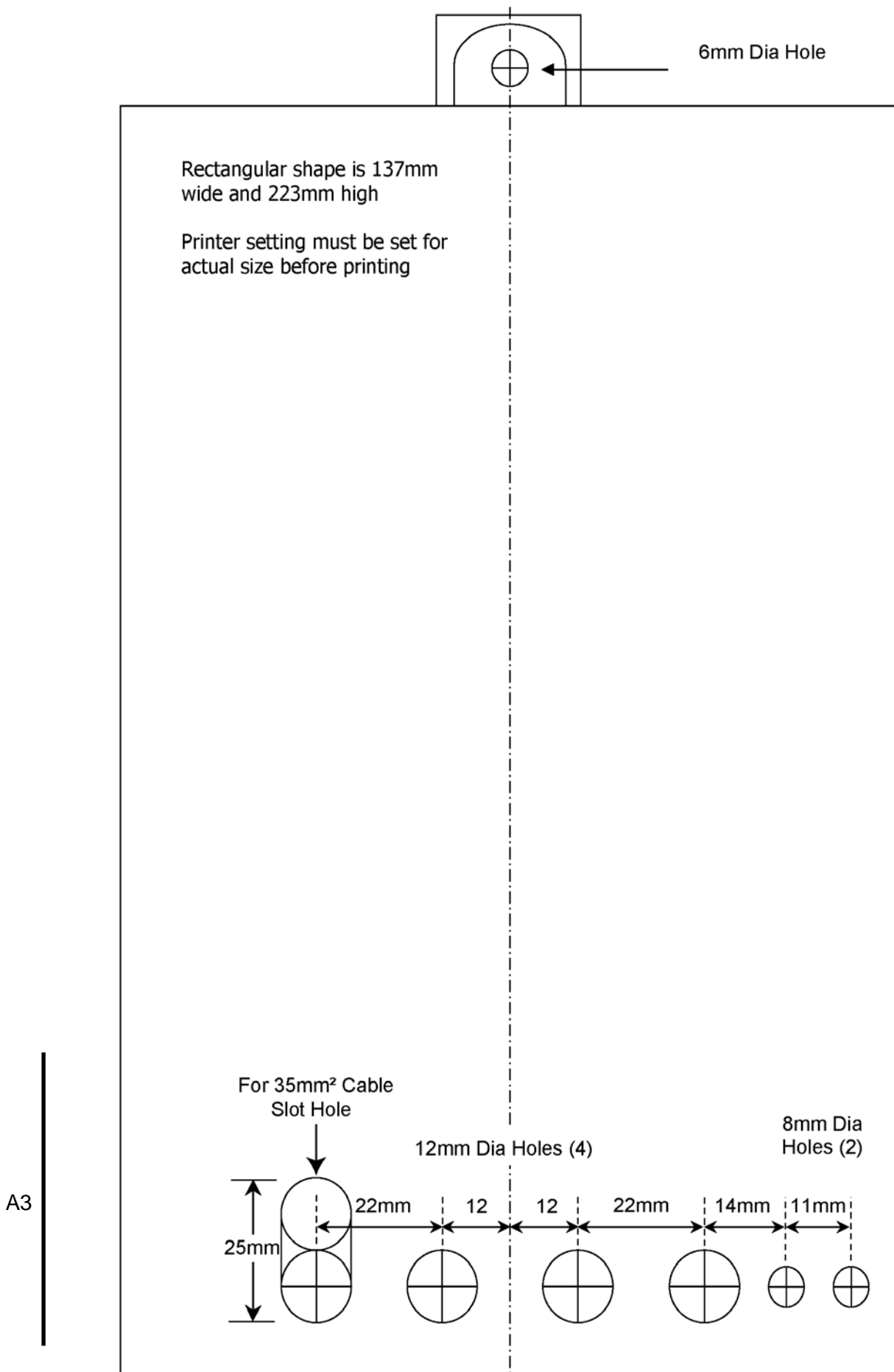

**Figure 8.10-W Single Phase Meter Drilling Template**

**This page intentionally blank**

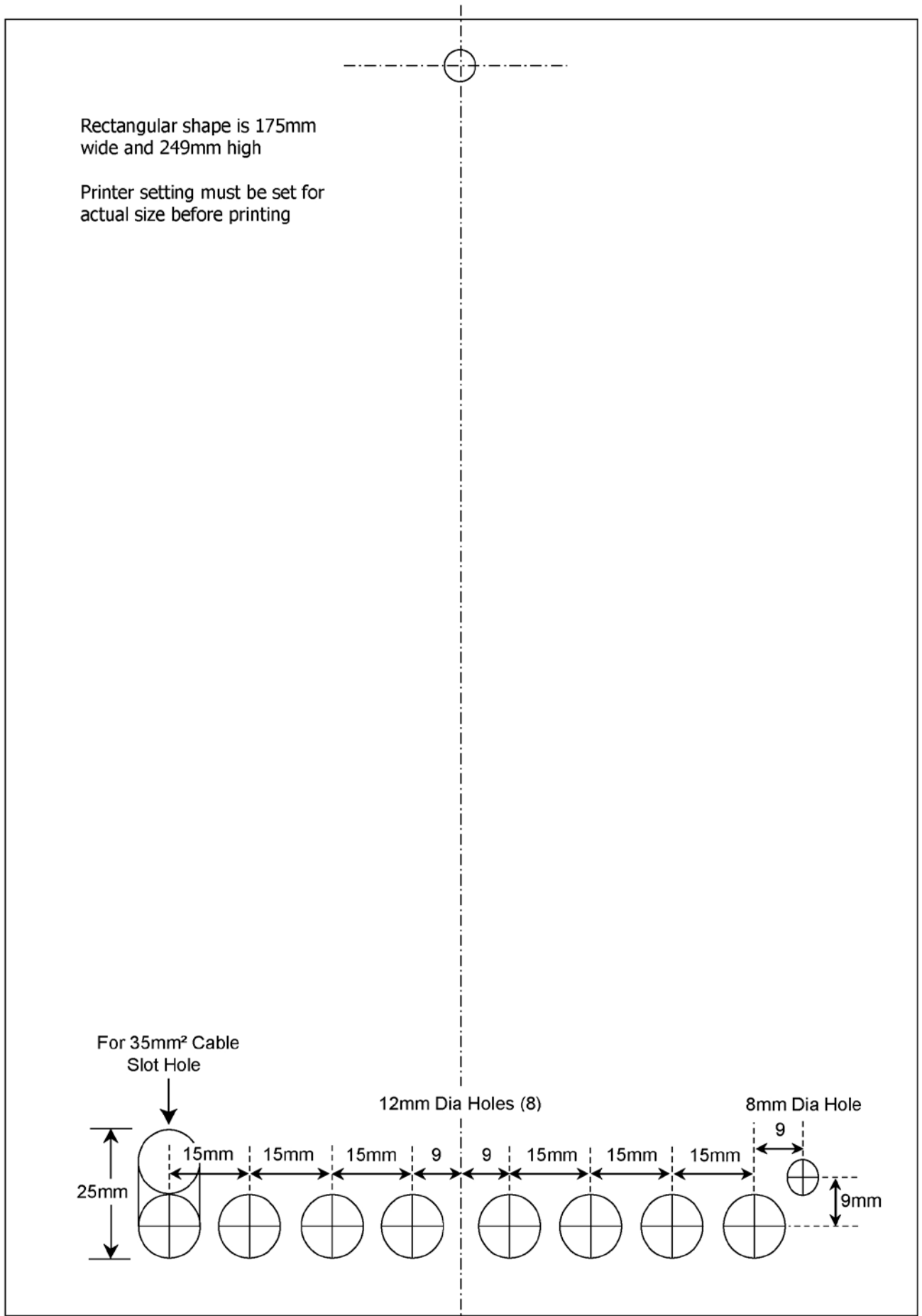

A3

Figure 8.10-X Multi Phase Meter Drilling Template

**This page intentionally blank**

### 8.10.3 Embedded Networks

An embedded network is formed when a 'parent' or 'gate' meter is placed between meters of multiple customers and the poles and wires that form part of the Victorian Distribution Network. This simple act transforms all the electrical distribution system on the customer's side of the parent meter into an embedded network and the customers' meters into 'child' meters.

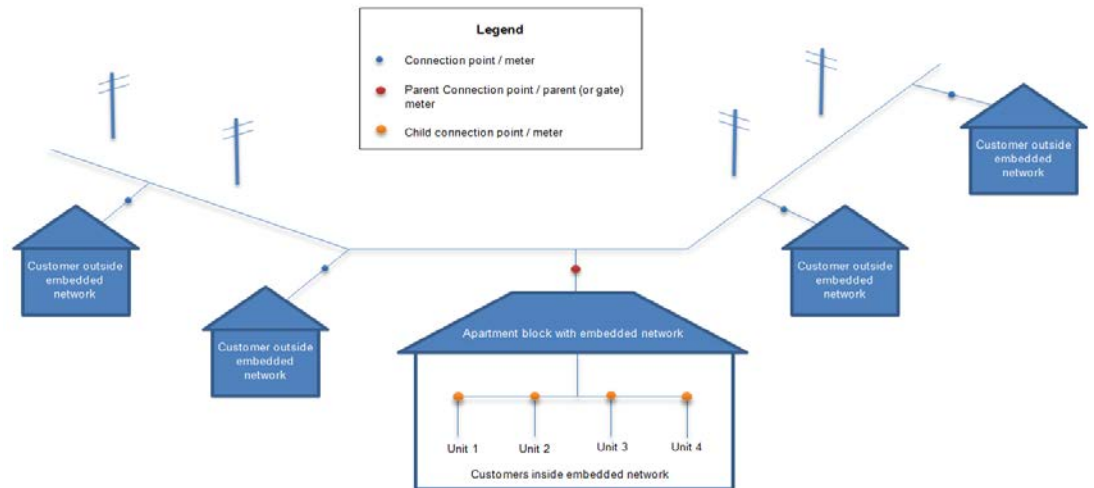

**Figure 8.10-Y Illustrates an Embedded Network in an Apartment Block.**

All Embedded Networks shall, at all times, be installed, operated and maintained in accordance with all applicable requirements within the jurisdiction in which the network is located for the safety of persons and property. This includes, where relevant any industry Code, Rule or Guideline otherwise applicable to a network service provider providing similar services.

#### 8.10.3.1 General

As provided for in the AER - Electricity Network Service Provider – Registration Exemption Guideline, an Exempt Network Operator (ENO) shall ensure that;

- All metering installations used in an exempt network are fit for purpose and
- Compliant with the requirements of the National Measurement Act and
- Any Act administered by the National Measurement Institute and
- The regulations in force under that Act.

An exempt network metering installation for which an Embedded Network Manager (ENM) shall be appointed shall be installed and operated consistent with the AEMO Metrology Procedure:

- Part A National Electricity Market.

The metrology procedure and technical standards applicable to a metering installation remain subject to the laws of the jurisdiction in which the installation resides.

This requirement includes compliance with these rules in the jurisdiction in which the meter is installed.

The Embedded Network shall meet the requirements of the National Electricity Rules. Refer AEMO NEM Network Service Provider Registration Guide, AER 'General

exemptions from the requirement to register as a network service provider’ (General Exemptions), and ‘Guidelines for exemption from the requirement to register as a network service provider’ (Exemption Guidelines issued by AER).

Generally, the proposed arrangement for Parent and Child metering, and for a conversion to an Embedded Network requires a list to be prepared by the ENO. The list shall include information relating to all customers, the NMI, meter number and if the customer will be an ENOC or NEMC.

In addition, the following information shall be provided to the LNSP by the proposed ENO as soon as possible:

- the individual or company name and ABN of the entity undertaking the activity or activities and the entity’s registered address
- contact details for the entity’s representative including Business hours and 24 hour fault and emergency contact
- the number of properties and location of the properties where small scale activities are undertaken for each property
- details of the body corporate and owner or occupier of each premises.
- whether generation, distribution and/or resale of activities is undertaken at each location
- whether the customers within each location are residential, small business (consuming less than 160MWh per annum) and/or large business (consuming more than 160MWh per annum)
- the number of supply points (POS) in each network operated by the ENO

A2

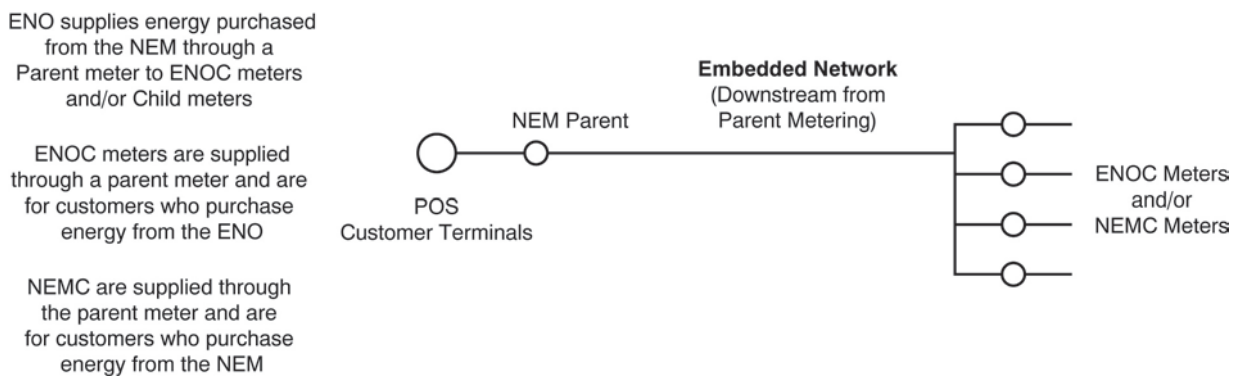

**Figure 8.10-Z Single Installation – Embedded Network (Downstream of Parent Meter)**



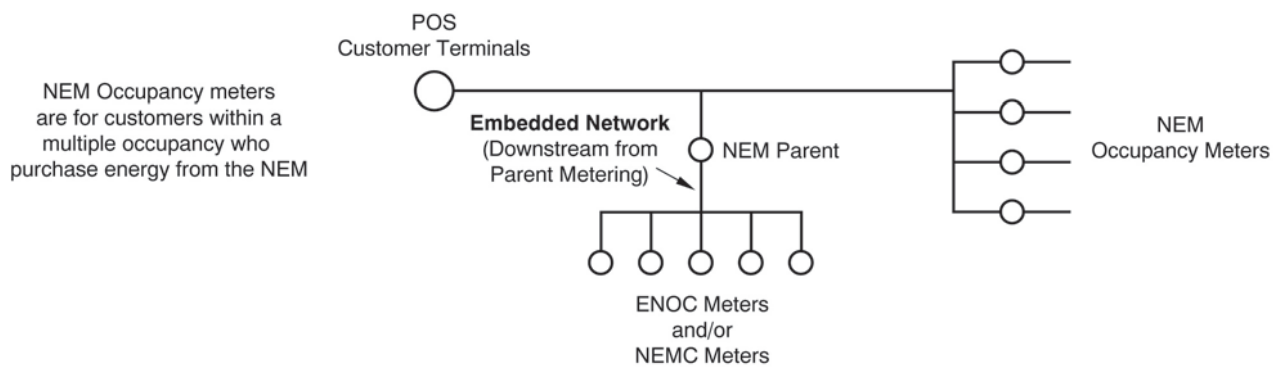

**Figure 8.10-AA Single Installation - Multiple Occupancy including an Embedded Network**

### 8.10.3.2 Facilities

Facilities for the installation of NEM metering shall be provided in accordance with these Rules requirements applicable to multiple occupancies. In addition, the following clauses apply.

### 8.10.3.3 National Electricity Market (NEM) Metering

These Rules apply to the supply, distribution and metering installed for the recording of electrical energy to any customer including at the:

- Parent Metering Point installed for ENO
- Customer metering point within the property upstream of a Parent Metering Point
- NEMC metering point installed for customers connected to the embedded network who purchase electrical energy from the National Electricity Market from a Retailer.

#### a) Typical metering at the Parent Metering (NEM) Point

- Installed in accordance with these Rules
- Labelled “Parent Meter”, NMI, Metering Provider
- Meters total energy supply consumed by embedded network.
- Metering owned, installed and maintained by the AEMO accredited Metering Provider engaged by a Metering Coordinator (MC).
- Metering CTs at the parent metering point shall be provided by the LNSP.

#### b) NEMC metering

- Installed in accordance with relevant sections of these Rules
- Labelled “Child Meter ON Market”, NMI, Metering Provider
- Metering CT’s for any NEMC shall be provided by the ENO

### 8.10.3.4 Embedded Network Operator Customer (ENOC) Metering

Embedded network operators are responsible for the embedded network customer meter management, including provision, installation, maintenance and electricity supply faults that occur within the embedded network. The metering is to be installed and managed in accordance with Regulatory requirements and persons shall be suitably licensed to perform the electrical work.

A2

Where an existing electrical installation consisting of NEM meters is to be converted to an Embedded Network consisting of ENOC meters, then the entire installation is to comply with these Rules, e.g. Timber and or Asbestos meter board/panel shall be replaced.

These Rules apply to the supply, distribution and metering arrangements for customers' who purchase their electrical energy from the embedded network operator, the installation shall be constructed in accordance with these Rules.

Replacement of NEMC meters with ENOC meters on a timber or Asbestos meter board /panel is not permitted. Replacement of the meter board/ panel is required.

ENOC metering may be installed on a customer supplied meter panel that complies with these Rules which contains, or is proposed to contain, NEMC metering provided the metering installation is performed by an AEMO accredited Metering Provider.

ENOC metering CTs are to be provided by the ENO.

#### **a) ENOC metering requirements**

- Labelled "Embedded Network Operators Meter" (to avoid ownership and responsibility confusion when metering)
- Installed for customers of an embedded network operator
- Are normally owned, installed and maintained by the embedded network operators nominated Metering Provider.
- Need to be installed and managed in accordance with relevant legislative (via relevant Commonwealth/State Uniform Trade Measurement Legislation) requirements.
- May be installed on a customer supplied meter panel that complies with these Rules which contains, or is proposed to contain, NEMC metering provided the metering installation is performed by an AEMO accredited Metering Provider. This approval does not remove others from complying with Clause 8.4.5.2 that does not allow ENOC meters to be installed on a meter panel.
- Customer responsible to embedded network operator for energy consumed
- Metering CTs for any ENOC will not be provided by the LNSP.

#### **b) Embedded Network Meter Labelling**

Embedded network meters are to be suitably labelled to avoid confusion. A label identifying each individual "Parent Meter", Child Meter On Market and "ENOC Meter", Metering Provider name and contact phone number shall be fitted in a conspicuous position on or adjacent the respective meter. Label character size shall be not less than 6 mm.

### **8.10.3.5 Conversion to an Embedded Network**

Existing installations may require substantial alterations to their wiring and metering arrangements to convert to an embedded network.

Substantial rework may be necessary to enable compliance with the Wiring Rules.

To ensure correct co-ordination and compliance, a detailed plan of the proposed supply, distribution and metering arrangements for any proposed embedded network or proposed changes to an existing embedded network shall be provided to the relevant Distributor at least two months prior to the proposed changeover date.

### **8.10.3.6 Embedded Network Planning**

The Proponent shall submit to the relevant Distributor, at least two months prior to the proposed changeover date, an electrical Single line diagram and Building general

A2

arrangement which delineates the boundary of the Embedded Network within the property.

The following information shall be provided to the relevant Distributor prior to consolidation of planning and commencement or modification of the embedded network:

Details of any existing customers who intend to convert to customers of the embedded network including:

- National Metering Identifier (NMI)
- Meter Number and Location
- Proposed supply, distribution, protection and control
- Parent metering
- Proposed demand
- Proposed Timeframes to create or modify the embedded network
- 24 hour Contact details for the ENO
- Details of any generation, standby generation or alternate sources of supply

A minimum of three weeks notice shall be provided to the Network Operator for the proposed changeover along with the final and complete list of customers to be connected to the embedded network and the status of either an ENOC or NEMC

### 8.10.3.7

## **Embedded Network Operational Requirements**

### **Electrical Installation Safety**

The ENO is responsible for the electrical safety including the electrical protection of the Embedded Network. All electrical work beyond the point of supply is the customer's responsibility and shall conform with the requirements of the Electricity Safety Act, Electricity Safety (General) Regulations, Wiring Rules and these Rules (to the extent that they apply to the electrical installation), the Distribution Code and all other relevant Rules, Codes or Standards.

### **Disputes**

- In the event of a dispute, the person registered shall make reasonable endeavours to resolve the dispute and continue to distribute or supply electricity to the customer.
- Inform customers of their right to access the services of EWOV or VCAT's dispute resolution mechanism.

### **Regulations**

- Observe the provisions of the Electricity Safety Act or the Regulations or any other instruments made under the Act.
- Observe any Code or Guideline that the AER may issue in relation to embedded networks.
- Observe all applicable provisions of the Electricity Distribution Code.
- Observe all applicable provisions of the NER and AEMO Metrology Procedures
- Not cease to distribute or supply electricity to a customer unless the circumstances of disconnection (including all necessary steps as prescribed by Commission Codes, Guidelines and Procedures) are the same as those that would apply if the customer was supplied by a licensed Retailer and that Retailer legitimately requests disconnection of the customer.

Advice to the ENM for each NEMC in relation to outages reconnections and disconnections and ENO functions which impact on any NEMC.

### **Embedded Network Operating Procedures**

As the operator of an Embedded Network the ENO shall;

- prepare operating procedures for the Embedded Network, the operating procedures shall include outage notification procedures for all customers connected to the Embedded Network, and
- authorise in writing, persons trained in the operating procedures who have been approved by the ENO for operating the installation.

Authorised persons shall;

- Be licenced for the type of electrical work being performed
- Be authorised and trained in the VESI Installation Supply Connection Tests & Procedures (ISCTP)

## **8.11**

### **LV Current Transformer Metering**

#### **8.11.1**

#### **General**

Where in accordance with clause 8.8 (Determination of Meter Current Carrying Capacity) current transformers (CT) metering is to be installed, the applicable requirements of clauses 8.1 to 8.10 and the following rules shall apply.

The customer shall provide adequate space, housing and facilities for the current transformers and metering equipment as detailed in these Rules. Details of the proposed electrical installation loading shall be provided to the relevant Distributor for the purpose of determining the correct CT size. The customer shall provide adequate notice to:

- the relevant Distributor who will supply the current transformers and standard 2.5 mm<sup>2</sup> wiring loom up to a maximum length of 10 metres, and
- to the relevant Retailer who will arrange for the installation of the metering equipment by the Metering Provider.

#### **8.11.2**

#### **Meter Panel**

##### **8.11.2.1**

##### **Panel**

A separate meter panel shall be provided for each CT meter installation.

The meter panel size shall be a minimum of 600 mm H x 600 mm W and a maximum of 900 mm H x 600 mm W plus 10% for a single CT metering installation.

Direct connected metering shall not be installed on the same panel as CT metering.

The meter panel shall be prepared and drilled in accordance with Figure 8.11-G.

##### **8.11.2.2**

##### **Location and Access**

**FAQ 006**

The meter panel and equipment shall be located in accordance with clause 8.4 (Metering Facilities) and accessible in accordance with clause 8.5 (Access)

A clear level paved and illuminated space as shown in Figures 8.11-A and 8.11-B shall be provided in front of the metering position to allow access for meter reading and to accommodate test personnel and their equipment.

Note that clause 8.11.7.2 (CT Wiring Loom) limits the distance between the meter panel and CT chamber to a maximum of 10 m cable length of wiring unless otherwise agreed by the Responsible Officer.

The meter panel is not permitted in a location subject to varying high intensity magnetic fields.

The meter panel is not permitted in a location, enclosure or switchboard subject to temperatures in excess of the temperature limits of specified operating range as per clause 8.8.2.

Conductors carrying current equal to or in excess of 500 amps shall not be installed behind or near the meter panel and surround, unless effectively shielded by an earthed metallic screen or located in accordance with Table 8.11-1. A 50 mm clear space shall be maintained between the rear of the meter panel and any installed screen material.

A2 |

### 8.11.2.3 Clearances

Unless approved by the Responsible Officer, CT metered installations shall be arranged to meet the following clearances:

- The lower edge of the meter panel shall be not less than 700 mm or greater than 1400 mm above the floor or ground level for meter panels located within a meter enclosure, a switchboard enclosure, switchrooms, cupboards or rooms set aside specifically for metering. In all other cases the lower edge of the meter panel shall be not less than 1000 mm or greater than 1400 mm above floor or ground level.
- A minimum of 175 mm in front of the meter panel to the inner face of the door or any internal projection where the meter panel is enclosed.
- A minimum of not less than 50 mm behind the panel

Clear space for working on meters shall be in accordance with Figures 8.11-A and 8.11-B.

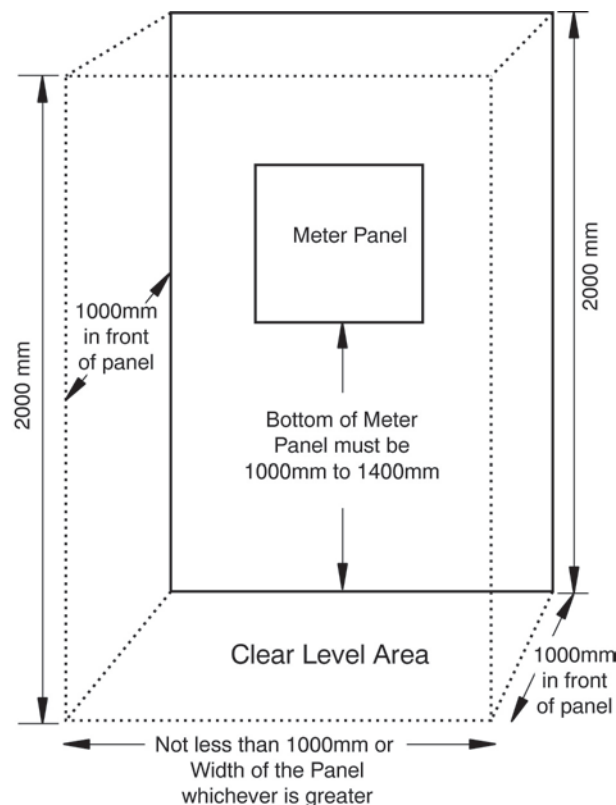

**Minimum Clearances & Heights**

A1 |

**Figure 8.11-A Unenclosed CT Meter Panel Heights & Minimum Clearances**

**This page intentionally blank**

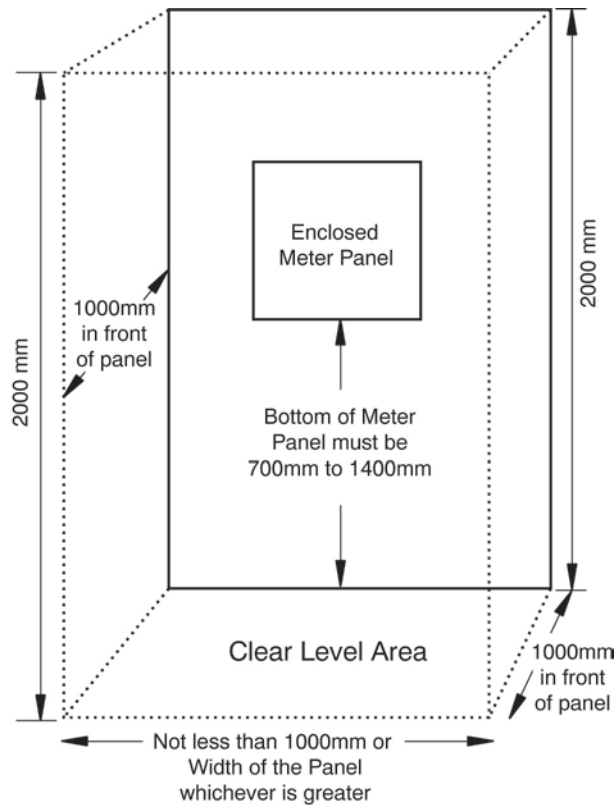

**Minimum Clearances & Heights**

**Figure 8.11-B Enclosed CT Meter Panel Heights & Minimum Clearances**

Unless effectively shielded by an earthed metallic screen from heavy current carrying conductors, the following clearances stated in Table 8.11-1 shall be maintained between the conductors and meter panel:

The CT wiring loom shall not be installed less than the distances provided in Table 8.11-1, where installed within close proximity of conductors carrying current equal to or in excess of 500 amps.

**Table 8.11-1 Conductors to Meter Panel Clearances**

RATING OF CONDUCTOR (Amps)	DISTANCE BETWEEN METER PANEL AND THE NEAREST CONDUCTOR (mm)	
500	200	Interpolate for intermediate values
1000	400	
2000	600	
3000	800	

**8.11.2.4 Wiring**

Unless otherwise required by the Responsible Officer, the preparation, provision and installation of the meter panel wiring, meters and associated equipment shall be the responsibility of the Metering Provider.

The meter panel shall be prepared and wired in accordance with Figure 8.11-G, and all wiring shall be connected in accordance with Figure 8.11-H.

The responsibility for provision and installation of the wiring loom shall be in accordance with clause 8.11.7.2 (CT Wiring Loom).

Where the Metering Provider requires, the meter panel shall be delivered to their premises to enable preparation of the meter panel prior to visiting the site.

**8.11.3 Current Transformers**

**8.11.3.1 General**

Facilities separate and distinct from the meter panel facilities shall be provided for the current transformers in accordance with this clause.

**8.11.3.2 Types & Supply**

Current transformers shall be supplied by the relevant Distributor. The sizes of metering current transformers used may vary and advice should be obtained from the Responsible Officer regarding the type to be used in any specific project. Those in common use are:

Type S	200/5 A Single Ratio
Type B	400–800–1200/5 A
Type C	1000–2000–3000/5 A
Type T	800/5 A Single Ratio
Type W	1500/5 A Single Ratio

Typical dimensions for current transformers are provided in Figure 8.11-E.

**8.11.4 CT Isolation**

Isolation of current transformers shall be in accordance with clause 8.10.1 (Single Occupancy) and the following for multiple occupancies – Refer to Figure 8.11-C.

The ODD for CT metered occupancies within a multiple occupancy building shall be:

- located in a position that can be readily and safely accessed by the relevant Distributors representative at all times;
- capable of isolating the conductor’s that pass through the CTs;
- capable of being locked in the off position, and/or located in a position with a facility for the ODD enclosure to be locked with a padlock with a 5.5 mm diameter hasp; and
- located adjacent to the meters or have a permanent and legible diagram installed at the meter position which accurately shows its location and access arrangement.
- Can be either a Circuit Breaker (CB) or a Combined Fused Switch (CFS)

Any ODD controlling Safety Services shall be labelled in accordance with the regulations and the wiring rules.

**8.11.4.1 Single Occupancy**

Current transformers for a single occupancy electrical installation shall be located on the supply side of the main switch/es and be arranged to allow isolation of supply to the CT’s by means of a supply protection device.

**8.11.4.2 Multiple Occupancy**

Current transformers for a multiple occupancy electrical installation shall be located where they can be removed or replaced without interrupting supply to other customers.

Where occupancies are dependent on a CT metered supply for ancillary services such as public lighting, air conditioning and safety services and they cannot be occupied without such services remaining operational, separate isolation of the supply for ancillary services is optional, provided the aforementioned principles are demonstrated.

A2 |



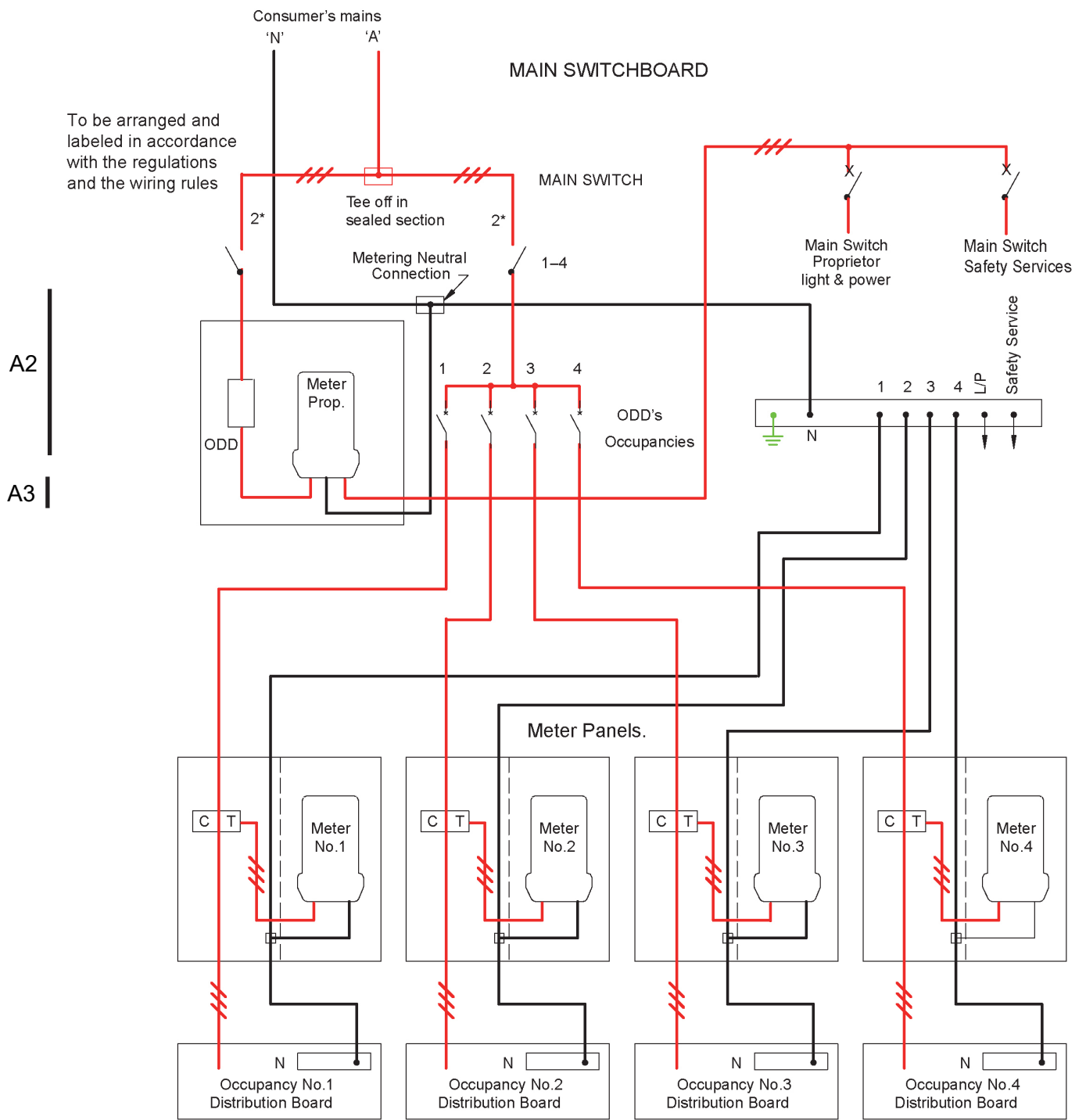

To be arranged and labeled in accordance with the regulations and the wiring rules

A2

A3

Notes

1. A plan of the installation showing the location of the metered and un-metered Mains and sub-mains in relation to the main structural features, together with a schematic diagram indicating the control, isolation and metering arrangements of the installation, shall be submitted to the Responsible Officer for approval prior to the intended commencement of the installation.
2. Attention to Wiring Rules regarding switches controlling Safety services is recommended.
3. SPD shall be located in accordance with Tables 7.2-1, 7.3-2, 7.4-3 or 7.5-1 which ever is applicable.

A2

**Figure 8.11-C Typical Wiring Diagram for 4 CT Metered Occupancies and Proprietor with Direct Connected Metering**

## 8.11.5 CT Enclosures

### 8.11.5.1 General

**FAQ 022**

Metering current transformers shall be mounted in a dedicated enclosure in the form of a box type enclosure equipped with a hinged door which will accommodate the CTs in accordance with Figure 8.11-E and Figure 8.11-F and their associated wiring and equipment.

MEN connection, busbars, wiring or equipment other than that required for metering purposes shall not be located within a CT enclosure. The CT enclosure shall provide effective segregation from other busbars or conductors.

Active busbars, cables and cable terminations shall not extend forward of the CT secondary terminals and shall not obstruct the clear opening dimensions as detailed below.

Neutral and Earth busbars, cables and terminations may be located forward of the CT secondary terminals and shall not obstruct the clear opening access dimensions detailed below.

Potential fuses and their associated wiring may be located forward of the CT secondary terminals and shall not obstruct the clear opening dimensions detailed below.

CT enclosures shall be constructed of materials used for meter enclosures and surrounds specified in clause 8.4. (Metering Facilities).

The minimum space inside the CT enclosure shall be not less than:

Conductors Arranged Horizontally;

- For in-line mounting arrangement – 620 mm H x 400 mm W x 300 mm Deep.
- For trefoil mounting arrangement – 500 mm H x 600 mm W x 300 mm Deep.

Conductors Arranged Vertically;

- For in-line mounting arrangement – 620 mm W x 400 mm H x 300 mm Deep.
- For trefoil mounting arrangement – 500 mm W x 600 mm H x 300 mm Deep.

Busbars contained within the CT enclosure shall not change direction after they enter or before they exit the CT enclosure.

Adequate additional space shall be provided to allow for cable terminations or entry of cables.

The minimum space required for terminating a Distributor's service cable within a CT enclosure shall be in accordance with clause 7.3.2.4 (Consumer's Terminals).

The clear opening through which access to the CT's is obtained shall not be less than:

- In-line mounting arrangement – 560 mm x 340 mm.
- Trefoil mounting arrangement – 440 mm x 540 mm.

The enclosure shall not be less than 300 mm deep with ready access to the CT's at all times.

The CT enclosure shall be fitted with a hinged door or hinged panel which shall have provision for sealing in accordance with Clause 8.4.5.3 (Sealing and Locking)

The door shall be:

- hinged on a vertical side and capable of being secured in the open position at a minimum of 90 degrees to the closed position; or

- hinged at the top if the door is capable of being secured in the open position at a minimum of 170 degrees to the closed position; and

equipped with:

- a handle to open and close the door;
- a latch or securing device to retain the door in the closed position, the device shall be arranged to prevent contact with exposed live parts when the door is closed;
- sealing facilities to enable the door to be sealed in the closed position by the Metering Provider or locking facilities for a padlock with a 5.5 mm diameter hasp if the enclosure is in an outdoor location unless otherwise approved by the Responsible Officer; and
- a label “Electricity Metering Transformers” complying with clause 5.4 (Labelling).

### 8.11.5.2 Location

Clause 8.11.7.2 (CT Wiring Loom) limits the distance between the meter panel and CT enclosure to a maximum of 10 m cable length of wiring unless otherwise agreed by the Responsible Officer.

Clear space for working on CTs shall be a minimum of 1.2 m wide, 1m deep from the CT terminals and of sufficient height to allow work to be performed safely on the CTs.

Unless otherwise approved by the Responsible Officer the minimum mounting height from the ground, floor or platform to the bottom of the lowest CT shall be 500 mm and the maximum mounting height to the top of the highest CT shall be 3 m.

The enclosure shall be installed in a position to enable work on the CTs to be performed safely and conveniently.

Access to the CT enclosure door and equipment within the enclosure shall be such that persons accessing the enclosure are not exposed to live equipment other than that within the CT enclosure.

### 8.11.6 CT Mounting

The customer shall provide the necessary primary conductors and install the CT's.

Friction clamping of CT's to busbars is not acceptable. Methods of mounting current transformers shall be in accordance with this clause and Figures 8.11-E and 8.11-F, ie:

- “in-line” (ie. The bodies of each CT are in the one line); or
- “trefoil” where the centre phase CT is offset from the other two.

For “trefoil” arrangements, the spacing between centres of busbars shall not be less than 125 mm for currents up to 1200 A and not less than 150 mm for currents above 1200 A.

For “inline” arrangements, the spacing between centres of busbars shall not be less than 205 mm

The mounting of CTs shall be such as to allow sufficient space:

- to terminate the primary and secondary conductors;
- to provide for easy CT removal and replacement; and
- to provide safe access to CT secondary terminals for tap changing, regulatory testing and sealing of terminal covers.

CT's shall be mounted with the label “This side to Incoming Supply” or P1 or face with a red dot facing the incoming supply.

The secondary terminals of the CT's shall face outwards for accessibility and testing purposes and be as close as reasonably practical to the access of the enclosure and not more than 300 mm behind the closed door.

The conductor passing through the CT window shall be in the form of a removable section of busbar not less than 300 mm in length as shown in Figures 8.11-E and 8.11-F. Upon removal of the section of busbar, a gap of not less than 200 mm shall exist between any associated line side and load side busbar ends, to allow for removal of the CT. The size of the busbar shall provide for an air gap between the busbars and CT window.

### 8.11.7 CT Meter Voltage and Current Wiring

CT Meter Voltage and Current Wiring shall be connected in accordance with Figure 8.11-G.

#### 8.11.7.1 Fuses

The customer shall provide three 32 A fuse units that shall;

- be HRC, 440V with 32 A staggered offset tag cartridge fuse to AS 2005;
- form part of the active metering voltage supply circuit;
- be installed within the CT enclosure and connected to the active conductors on the line side of the CTs;
- be securely fixed into position to prevent future movement of the fuse base;
- be positioned so as not to obstruct access to the CT secondary terminals and to enable the fuse wedge to be withdrawn toward the operator; and
- be mounted within the enclosure in a position that does not obstruct access for the purposes of installation, removal and testing the CT equipment; or
- be busbar mounted, provided the fuse bases are arranged to ensure the safe operation of the fuse wedges and the busbar surface supporting the base does not extend past the fuse base mounting surface.
- Cables used to connect the fuse units to the active conductors on the line side of the CTs shall be minimum size of 4mm<sup>2</sup> Single Core Double Insulated cable arranged to minimise the likelihood of a short circuit developing over the life of the electrical installation, ie, no potential to contact a busbar or conductor of the opposite phase, or exposed metal.



Unacceptable Arrangement



Acceptable Arrangement

**Figure 8.11-D Busbar Arrangement to Provide for Safe Operation of Fuses**

### 8.11.7.2 CT Wiring Loom

The relevant Distributor shall provide a standard 7 core 2.5 mm<sup>2</sup> wiring loom installed within facilities provided by the customer between the CT enclosure and meter panel.

A maximum route length of a standard wiring loom shall be 10 metres.

Where a longer route is required, the circumstances shall be referred to the Responsible Officer to enable the calculation of burdens and selection of appropriate conductor size.

Where conductors greater than 2.5 mm<sup>2</sup> are necessary the customer will be;

- required to meet the costs involved; and
- may be required to provide and install conductors, complete with identification in accordance with Figure 8.11-G, to the satisfaction of the Responsible Officer.

Within a switchboard, provision for the loom shall be provided in the form of channels, holes, knockouts or conduit of adequate sizes to install the loom.

Where the meter panel and CT enclosure are remote from one another, a 32 mm conduit shall be provided to accommodate a standard loom, and the Responsible Officer may specify a larger conduit where other than a standard loom is to be installed.

Unless otherwise agreed by the Responsible Officer, the conduit shall be rigid, and bends shall be used to negotiate corners and their number shall be kept to a minimum. The use of elbows is not acceptable.

A draw wire shall be provided where the loom is not installed at the time of the conduits installation.

A fixed neutral terminal comprising of a 6 mm tapped hole with a brass metal thread equipped with a flat and lock washer and nut where required shall be provided for the connection of the metering neutral in each CT enclosure.

The terminal shall be connected to the neutral associated with the active conductors being metered or the consumer's mains neutral prior to the CTs.

Where the neutral conductor does not pass through a connection within the CT enclosure, the conductor supplying the terminal shall be double insulated and a minimum size of 4mm<sup>2</sup>.

The tee off connection shall be located in an area and which is segregated from all other wiring and equipment, labelled "metering neutral", and provided with facilities to seal the area with a Distributor's seal.

Earthing of metal metering and CT enclosures shall conform with the requirements of the Electricity Safety Act and Regulations, including size of earthing conductor. Where earthing of a separate metering enclosure is required, the earthing conductor may be installed within the conduit containing the loom.

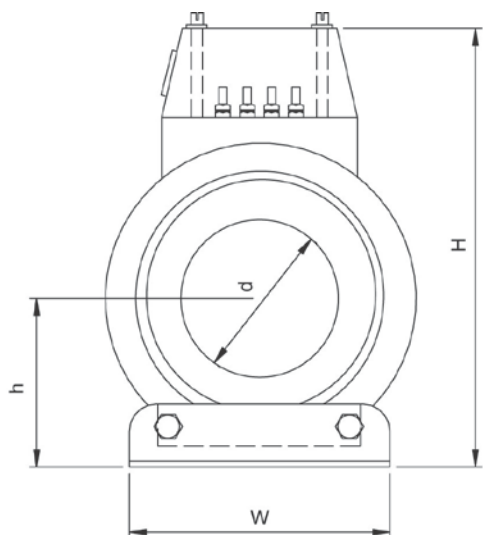

TYPE DESIGNATION	MAX WIDTH (W)	MIN WINDOW DIA. (d)	POSITION OF WINDOW CENTRE (h)	MAX HEIGHT (H)
S	130	45	65	165
B	165	85	85	230
C	165	112	87 or 115*	270
T	165	85	85	230
W	165	112	87 or 115*	270

\* Refer to Note 2

**NOTES**

1. Refer to clause 8.11.5 (CT Enclosures) and 8.11.7.1 (Fuses)
2. Confirm dimensions with the relevant Distribution Company (refer clause 8.11.3.2)

**CURRENT TRANSFORMERS**

\* For circuits carrying greater than 1200A, spacing shall be increased to not less than 150mm.

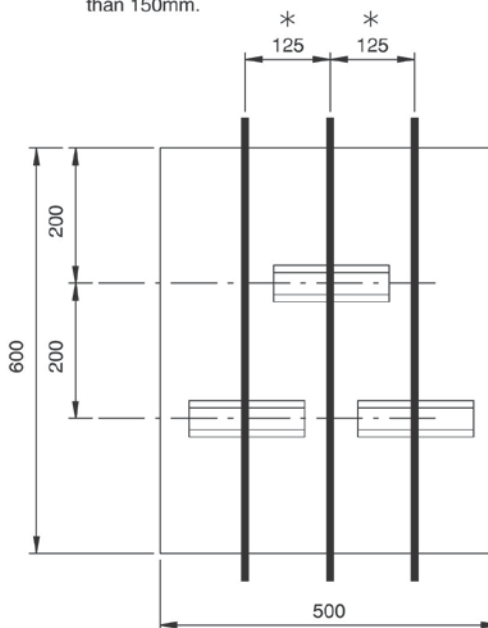
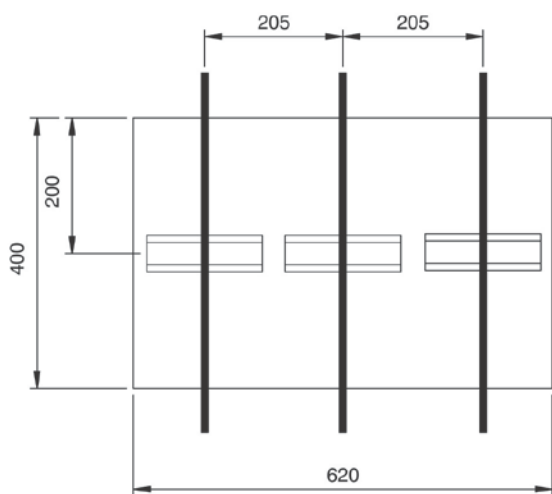

**MINIMUM SPACE IN CUBICLES FOR CURRENT TRANSFORMERS ONLY**

**Figure 8.11-E Dimensions of Current Transformers and Minimum Space Required in Enclosures for Current Transformers**

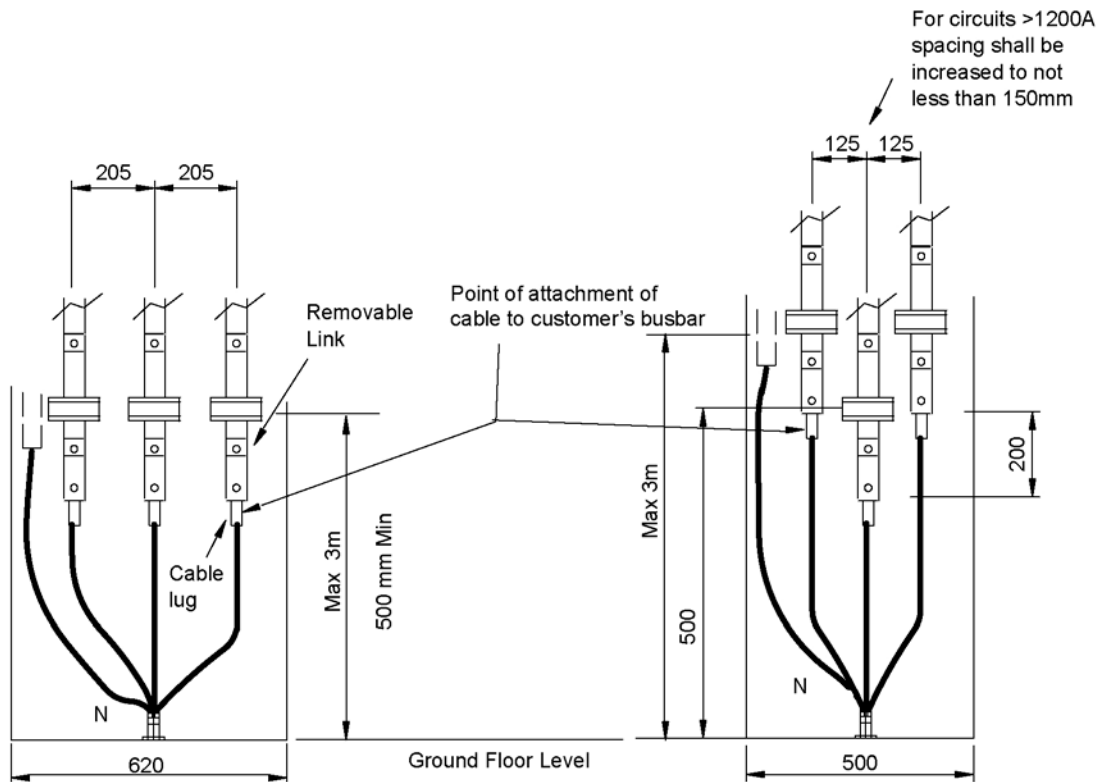

**NOTES**

1. Dimensions of all cubicles, front to rear are 300mm.
2. These drawings do not show 32 Amp meter voltage supply fuses in enclosures.
3. For terminating distributor cables, additional space may be required inside enclosure.
4. Refer clause 8.11.5 CT Enclosures and 8.11.7.1 Fuses
5. Refer to CI 7.3.2.4, Table 7.3-1 and Figure 7.3-B for Supply Connection Facility clearances

A3 |

**Figure 8.11-F Minimum Space Required in Enclosures for Current Transformers**

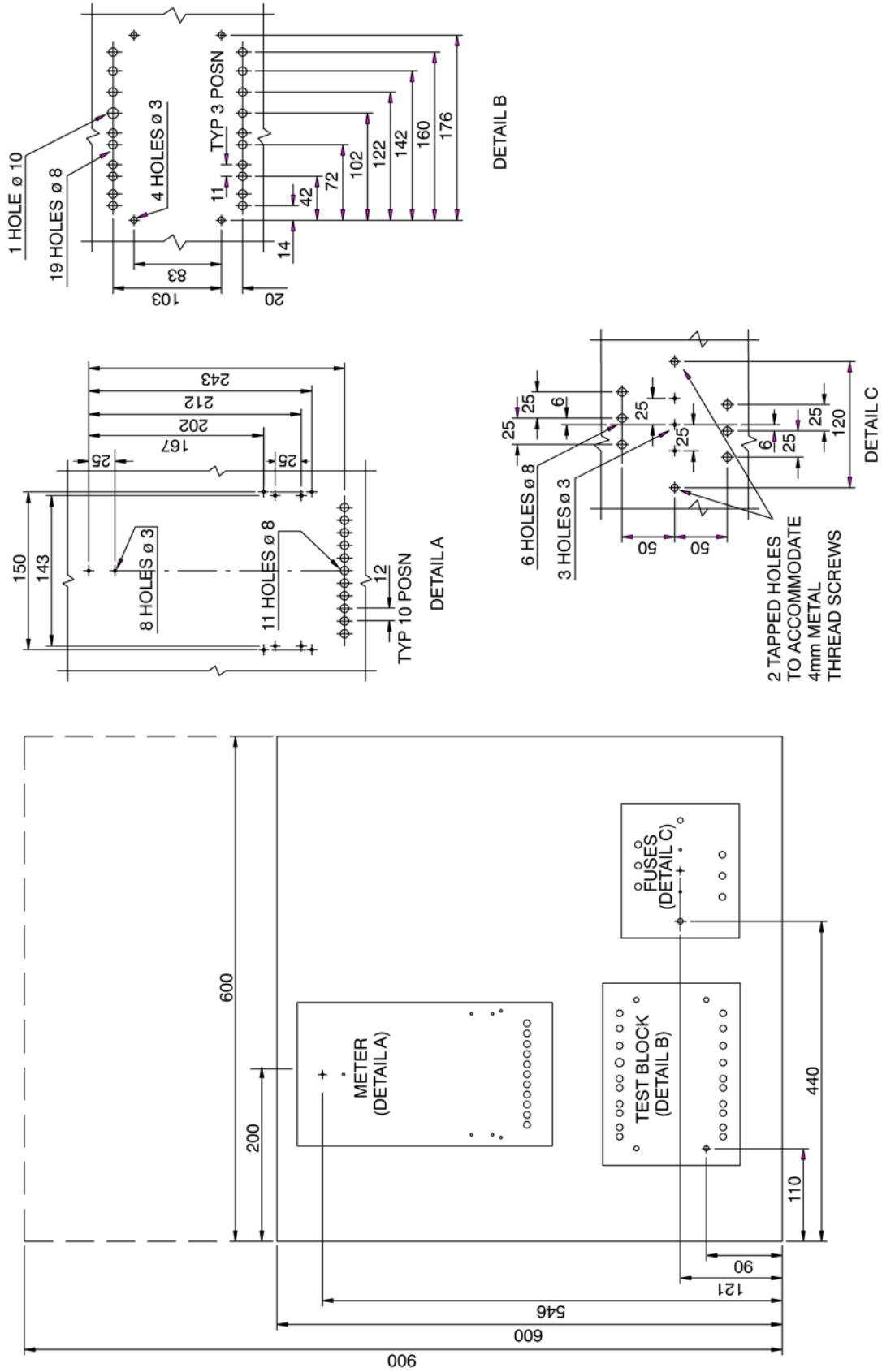
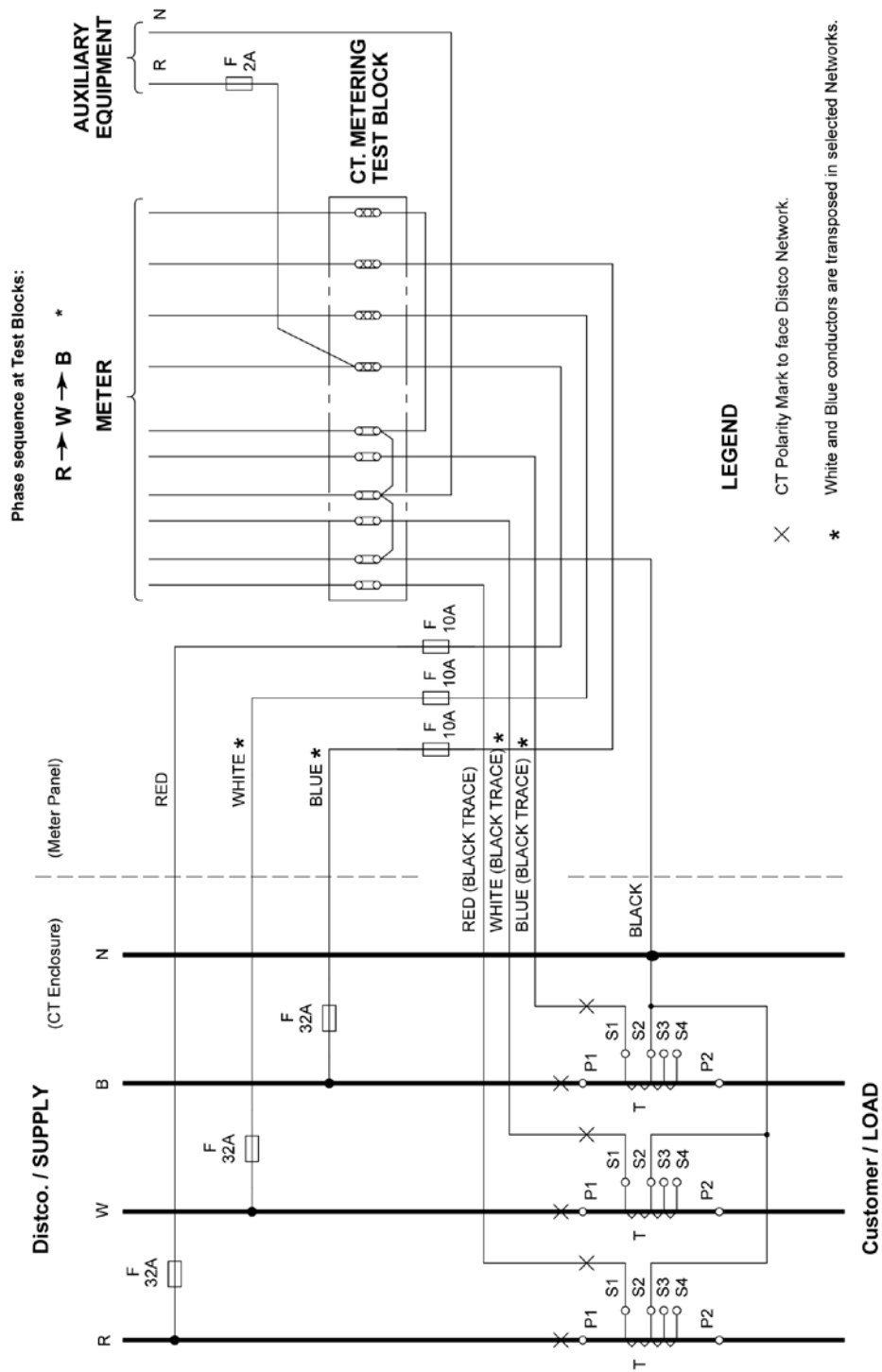

Figure 8.11-G Standard Current Transformer Meter Panel Layout





**Figure 8.11-H Typical Wiring Diagram for L.V. Current Transformer Metering  
(Including Generation Customers)**

## 8.12 Metering Communications Equipment

FAQ 003

### 8.12.1 General

Where the Metering Provider installs metering and communications equipment to enable the remote reading of the meter or other remote functionality, the following rules shall apply to the metering communications equipment. Equipment not owned and installed by the Metering Provider or Dist. Co. shall not be located on, in front of or in the wiring space behind, the meter or meter panel.

In the market definition of “metering installation”, and in the obligations imposed by the Victorian Advance Metering Infrastructure regulatory instruments, metering communications equipment forms part of a metering installation.

The metering communications equipment therefore forms a part of the metering installation for the purpose of these Rules.

Separate metering communications equipment may be provided for each individual meter, or multiple meters may utilise the same metering communications equipment, provided by the one Metering Provider.

Metering communications equipment complying with all relevant Regulations and Australian standards shall be supplied, installed and maintained by the Metering Provider and remain the property of the Metering Provider.

The customer shall provide a suitable location for metering communications equipment as a part of the obligation to meet clause 8.3 (Metering Obligations) of these rules.

In general, this requires the Metering Provider to install metering communications equipment in such a manner so as not to interfere with any facilities and wiring, other than that required to connect the metering communications equipment.

At the design stage of all installations, due consideration shall be given to the amount of space required and location for the metering equipment, including metering communications equipment. The meter panel diagrams in this document are the minimum requirements to cater for metering equipment supplied by Victorian Electricity Distributors

### 8.12.2

#### Equipment

Metering communication equipment may include but not be limited to the following:

- Multiplexer;
- Modem;
- External Antenna (antenna mounted in or on meter enclosure or meter panel);
- Remote Antenna (antenna mounted remotely from the meter enclosure or meter panel);
- Home Area Network (HAN) Interface / Repeater (where not a customer provided HAN);
- Communications Power Supply;
- Overload and short circuit devices provided for the protection of communication equipment;
- Power Cables associated with the communications equipment;
- Antenna cables;
- Associated fixings (Brackets, Conduits etc);
- Communication cables.

### 8.12.2.1 Location

With the exception of antennae, metering communications equipment shall be located on the same meter panel as the individual meter it serves.

The equipment shall be located on the meter panel of the associated meter, such that it will not obstruct any other electrical equipment, including the meter, SPD /ODD, neutral link, etc, and shall allow unhindered opening of the meter panel, and or enclosure door, removal of door where applicable, and removal of the meter panel.

In general, modems and antennae are internal to the meter, however, where an external antenna is required to meet communication requirements it shall be located in the following preferential order:

- Internal to the meter enclosure, and mounted on the meter panel; or
- Internal to the meter enclosure other than on the meter panel, in a location where it will not prevent the normal access and operation of metering equipment, panels door, switchboard etc; or
- External to the meter enclosure and mounted on the meter enclosure. Antenna installation and associated cabling shall be mounted such that it does not alter the integrity or IP rating of the meter enclosure; or
  - Where the external antenna is to be mounted on the top, bottom or sides of the meter enclosure, the enclosure shall not be fully recessed, by installing the enclosure 75 mm proud from the external surface of the wall into which it is installed; or
  - Where the meter enclosure is to be fully recessed, and the antenna is to be installed on the door, the enclosure shall be modified to ensure the door cannot be removed; or
- Remote from the meter enclosure, mounted on the customer's premises at a location provided by the customer and agreed with the Metering Provider. In the selection of external antenna locations electrical safety, radio safety guidelines, aesthetics, potential vandalism and damage should be taken into account in addition to communication performance. Wherever practical, the antenna should be mounted out of sight. E.g. within the wall cavity below the enclosure). Where due to building works etc, and the area set aside for the antenna aside becomes unsuitable, a new position shall be negotiated between the customer and the service provider;
- External antennae installed by providers other than distribution businesses shall not cause any interference with other distribution metering equipment.
- For remote read meters owned by the Distribution Businesses which are to be located within a basement a remote antenna (outside of the building) may be required for communication. During negotiation of supply the customer will need to consult with Distribution Businesses in the installation of conduit and antenna cabling.

### 8.12.3 Installation

#### 8.12.3.1 Connection of Communication Power Supply

The power supply for the metering communications devices shall have the appropriate protection, connection and cabling as detailed below and in accordance with the relevant standards.

These rules do not apply to metering communications equipment wholly contained within the meter or equipment installed under the meter terminal cover and not connected to the main supply.

A1

Power supply for metering communications devices shall originate as follows:

- For direct connect meter:
  - from the line terminal of the meter i.e. extending beyond the meter terminal cover; or
  - from the load side of the SPD or ODD device located on the meter panel prior to the meter;
- For current transformer connected meter from the meter side of the red phase voltage terminal of the metering test block.

The cable for the connection of the power supply shall be 4.0 mm<sup>2</sup> PVC V75, double insulated with copper conductors at a length no greater than 500 mm.

A protective device shall be provided with a maximum rating of 0.5 Amps (a slow blow fuse is recommended). If the protective device is not located within a sealed section of the metering equipment and is not in a sealable fuse holder, it shall be installed within a separate sealable enclosure or device.

Note: A thermal automatic re-settable circuit breaker may be used in place of a single operation fuse.

### **8.12.3.2 Communications Cabling, Communications equipment power cabling and antenna cabling**

Communications cabling, communications equipment power cabling and antenna cabling shall be installed and fixed, loomed and or cable tied in a manner that it will not obstruct any other electrical equipment (switchboard, escutcheons and meter panels) and their operational requirements. The installed cable shall be of a type and installed in compliance with the relevant standards.

### **8.12.3.3 Communications Devices**

Communications devices shall be installed using fixings, fastenings and supports of adequate strength and durability.

#### **External or Remote Antenna**

Antennae, mounting brackets and cabling shall be installed using fixings, fastenings and supports of adequate strength and durability. All external or remote antennae and cabling shall be installed and be of a type in compliance with the relevant standards. The penetration of the meter enclosure for the installation of a remote or external antenna shall be such that it does not affect the IP rating of the enclosure. The external antenna shall be located on the meter panel, or within or on the meter enclosure of the associated meter, in such a manner that it will not obstruct any other electrical equipment (switchboard, escutcheons or meter panels) and their operational requirements.

#### **Customer and third party provided Communication Equipment (e.g. HAN repeater)**

Customer **and third party** Provided Communication Equipment shall not be installed on the meter panel, or obstruct access to the meter panel. The installed equipment shall not obstruct or cause interference to other equipment, including the meter, SPD /ODD, neutral link and metering communications equipment.

# Section 9

## High Voltage (HV) Electrical Installations

The VSIR Management Committee would like to thank the following industry participants for their valuable assistance and knowledge sharing in the preparation of this section.

A3 | ABB  
AusNet Services  
CitiPower  
Electrical Inspections Victoria  
Metering Dynamics  
NHP  
Nilsen  
Powercor  
RANS Electrical  
Siemens  
Stowe Australia  
United Energy

<b>Section 9 - Contents</b>		<b>Page</b>
<b>9.1</b>	<b>Scope</b>	<b>9-4</b>
<b>9.2</b>	<b>Contractual Arrangements</b>	<b>9-4</b>
<b>9.3</b>	<b>Systems of Supply</b>	<b>9-4</b>
<b>9.4</b>	<b>Preliminary Information</b>	<b>9-5</b>
<b>9.5</b>	<b>Installation Design</b>	<b>9-5</b>
<b>9.6</b>	<b>Conversion from Low Voltage to High Voltage Supply</b>	<b>9-5</b>
<b>9.7</b>	<b>General Design</b>	<b>9-6</b>
9.7.1	Circuit Connections	9-6
9.7.2	Control of Incoming High Voltage Supply	9-6
9.7.3	Incoming Cable Connection Facility Space	9-7
Figure 9.7-A	Typical Underground HV Customer Example	9-7
<b>9.8</b>	<b>Protection</b>	<b>9-8</b>
<b>9.9</b>	<b>Insulation Co-ordination</b>	<b>9-8</b>
<b>9.10</b>	<b>Short Time Withstand Voltage and Current</b>	<b>9-8</b>
9.10.1	Short Time Withstand Current	9-8
9.10.2	Short Time Withstand Voltage	9-8
Figure 9.10.2-A	Typical REFCL Isolation Transformer Installation	9-9
9.10.2.1	Isolating Transformer Solution	9-9
9.10.2.2	Primary Assets Hardening Solution	9-9
9.10.2.3	Conversion to Low Voltage	9-10
9.10.2.4	Conversion to 66 kV	9-10
9.11	Earthing	9-10
9.11.1	General	9-10
9.11.2	Size of Earthing Conductors	9-10
9.11.3	Earthing of Metering Equipment	9-11
<b>9.12</b>	<b>Distributor's Acceptance Requirements</b>	<b>9-11</b>
<b>9.13</b>	<b>Metering</b>	<b>9-11</b>
9.13.1	General Requirements	9-12
9.13.2	Single Feeder Metering Requirements	9-12
9.13.2.1	Meters Panels	9-12
9.13.2.2	Freestanding Meter Enclosures	9-13
9.13.3	Metering Transformers	9-13
9.13.3.1	Compliance	9-13
9.13.3.2	Test Facilities	9-14
9.13.3.3	Mounted in Switchgear	9-14
9.13.3.4	Supplied from an Underground Cable	9-15
(a)	Located Outdoors	9-15
(b)	Located Indoors	9-15
Table 9-13-1	Metering Transformers Performance Guidelines	9-16
Figure 9.13-A	Typical 3 Phase 4 Wire Metering Wiring Diagram	9-17

A2

A2

<b>Section 9 - Contents</b>		<b>Page</b>
Figure 9.13-B	Typical Metering Marshalling Point and Metering Terminal Point	9-18
<b>9.14</b>	<b>Testing and Commissioning</b>	<b>9-19</b>
<b>9.15</b>	<b>Customer's HV Installation Operation and Maintenance</b>	<b>9-19</b>
9.15.1	Operating Procedures	9-19
9.15.2	Trained Operators	9-19
9.15.3	Maintenance	9-19

## 9.1 Scope

A2

This Section details a Distributor's requirements for Customers taking supply at high voltage, up to 66 kV installations. The purpose of this Section is to ensure the Customer's high voltage installation consists of suitable equipment, provides a safe environment to operating personnel and the general public and does not adversely affect the Distributor's supply system.

These requirements are additional to the requirements of Electricity Safety Act and Regulations and apply to both new installations, and alterations or extensions to existing Customer installations.

For loads above 10 MW which are either likely to grow or cause significant voltage fluctuations to the Distributor's supply system, supply at 66 kV should be considered.

This section also applies to embedded generators connecting to the network at high voltage.

## 9.2 Contractual Arrangements

A Customer requiring a supply of electricity at high voltage shall be required to enter into:

A2

- an Electricity Supply Contract with a Retailer; and
- an agreement with a Metering Coordinator
- an electricity distribution connection agreement, contract or deemed electricity distribution contract.

And where applicable:

- an Extension Agreement with the Distributor; and/or
- an electricity distribution demand agreement or contract

Refer to the AEMO for additional information for electricity market operation.

A2

Large generation supplies may need market registration.

## 9.3 Systems of Supply

The Distributor will negotiate the system of supply and the voltage of supply with regard to the proximity of its relevant high voltage systems to the Customer's point of supply and the nature of the Customer's load.

One of the following nominal supply voltages may be made available:

- 6.6 kV;
- 11 kV;
- 22 kV; or
- 66 kV.

As most of the existing 6.6 kV areas of supply are scheduled for conversion to either 11 kV or 22 kV, any Customer currently taking supply at 6.6 kV should take this into account.

The supply shall be made available at a nominal frequency of 50 Hertz (cycles per second).



**9.4****Preliminary Information****FAQ 017**

The Customer shall provide the earliest possible notice (preferably 12 months) to their selected Retailer, Metering Coordinator and the Distributor of the intention to plan for a high voltage supply.

The following preliminary information shall be provided to the Distributor and Metering Coordinator:

- A single line diagram of the proposed HV installation. (Refer Figure 9.7-A)
- An overall site plan showing the proposed location of the HV equipment, including the network connection point, VTs, CTs & metering panel location;
- The preferred Point of Supply (new installation);
- The anticipated annual GWh throughput;
- The anticipated maximum demand (MVA) required for the installation;
- Provide details of any proposed or existing HV and LV on-site generation
- Any disturbing loads (eg. large motors, large scale battery installations arc furnaces regenerative braking, etc).

Negotiations should precede detailed design work, placement of orders for equipment and letting of contracts to avoid loss to the Customer arising from designs or equipment being found by the Distributor or Metering Coordinator to be unsuitable for connection to the supply system.

**9.5****Installation Design**

The installations supply, protection, earthing and metering arrangements shall be:

- Installed to the requirements of the relevant Acts, LNSP requirements, and the relevant Australian standards, and.
- Metrology aspects of the design shall be acceptable by the nominated Metering Coordinator, and
- Arranged to comply to the requirements of Clause 6.5 (Supply Use Obligations) and the Electricity Distribution Code in respect to interference to the Distributor's supply system: and
- Comply with all applicable Regulations, National Electricity Rules, Codes of Practice, Metrology Procedures and these Rules.

Standards which should be referenced and installation components which should be considered include the items listed in the Appendices attached to this Section.

**9.6****Conversion from Low Voltage to High Voltage Supply**

Taking supply at high voltage may involve the transfer of ownership of high voltage assets.

Assets being transferred from a Distributor to private ownership shall comply with the Electricity Safety Act.

The installation compliance conditions are to be negotiated with the Distributor. Reconfiguration of the connection point from HV to LV requires reallocation of the National Meter Identifier (NMI).

A2

## 9.7 General Design

### 9.7.1 Circuit Connections

A2

The preferred supply arrangement is via a single Distributor high voltage feeder and all HV connections shall be separately metered.

Arrangements can be negotiated for a second, high voltage feeder where required. Paralleling of high voltage feeders may be permitted subject to the conditions as detailed in Clause 9.7.2.

### 9.7.2 Control of Incoming High Voltage Supply

FAQ 012, 018

A3

There shall be a maximum of one main switch per HV supply. Approval by the Distributors Responsible Officer is required if the design incorporates more than one main switch.

The main switch shall consist of an automatic circuit breaker/s capable of making and breaking the maximum prospective fault currents on all phases.

There shall be a maximum of two main switches.

Approval by the Distributor Responsible Officer is required if the design incorporates more than two main switches.

The main switch or switches shall be:

- located as near as possible to the Customer's Point of Supply; and
- readily accessible to authorised persons; and
- provided with adequate means of isolation and safety earthing for maintenance purposes.

In addition to the above requirements and in accordance with the requirements of the "Code of Practice of Electrical Safety For Work On or Near High Voltage Electrical Apparatus" (Blue Book) the following is required:

- The incoming high voltage cable shall be capable of being earthed via a fully rated earth switch located on the supply side of the main switch circuit breaker. The earth switch may be located either on the line or load side of the CT VT cubicle.
- The earth switch shall be integral to the high voltage metering transformers

A2

The earth switch shall be capable of being locked in the "OFF" and "EARTHED" positions and shall remain under the operational control of the Distributor who shall fit their operational locks to the earth switch.

The locking facility on the earth switch shall be suitable for padlocks with a 10 mm shackle.

Remote operation of the earth switch on the line side of the main switch is not permitted.

Normally, where more than one high voltage supply is provided to a Customer, the main switches shall be interlocked in such a manner that paralleling of the high voltage supplies shall not be possible.

Where technically feasible, consideration will be given to allowing momentary paralleling of the Distributor's high voltage feeders, to permit transfer from one feeder to the other without interruption to supply.

Permanent paralleling of high voltage feeders to provide a no break supply may also be considered, subject to the installation of additional protection at the zone substation and the Customer's installation at the Customer's expense.

### 9.7.3 Incoming Cable Connection Facility Space

Where the Distributors cable terminates in the customers switchboard the following space requires shall be provided:

- 900 mm clear space below the termination point; or
- Trifurcating a multicore cable outside of the switchboard; or
- Use single core cables above any gland plate

This may be achieved by the use of a trench, pit or similar below the switchboard.

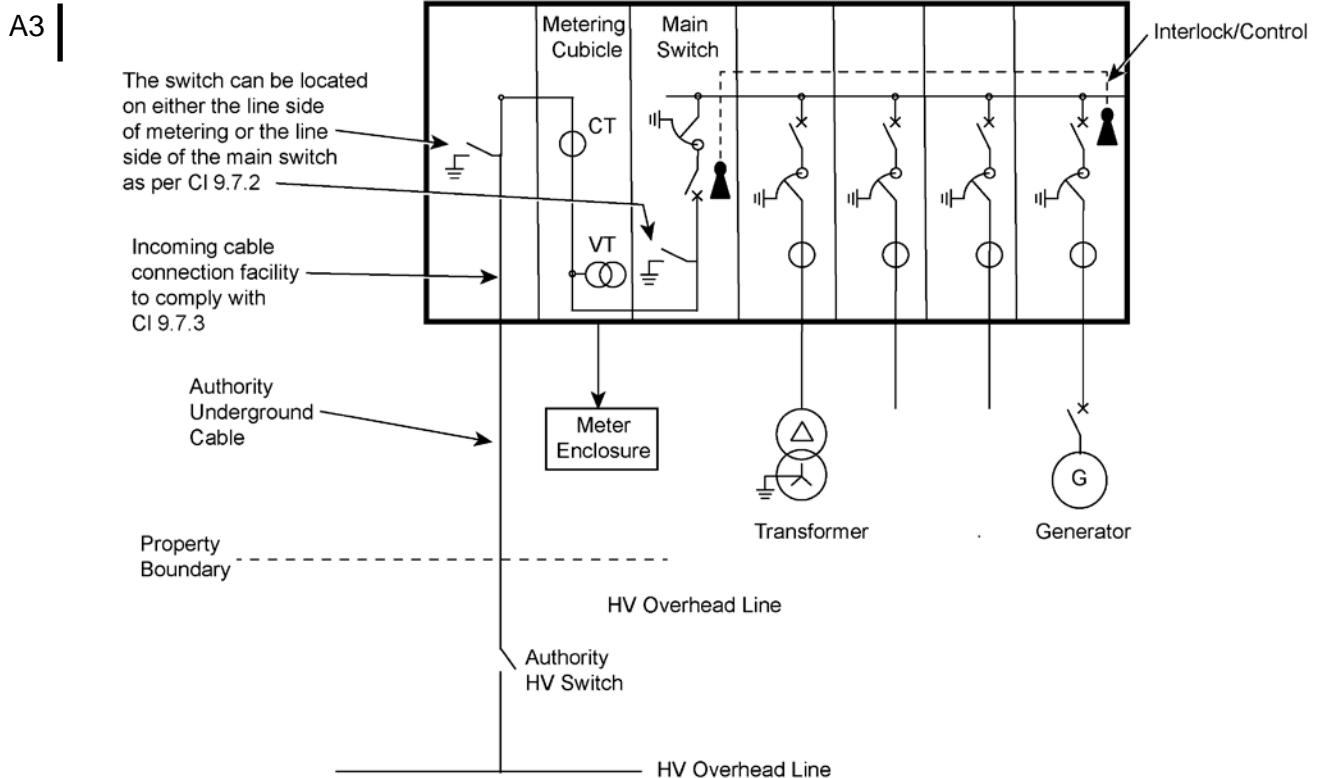

#### NOTES

- The point of supply shall be agreed between the Distribution company and the customer.
- Dual wound VT must be located on the load side of metering CT.

Figure 9.7-A Typical Underground HV Customer Example

FAQ 019

## 9.8 Protection

The main incoming circuit breaker/s shall be fitted with a protection system which is compatible with the Distributor's high voltage protection system. The Customer shall test the main protection system at the time of commissioning the installation to demonstrate that the performance meets the design parameters.

Prior to placing orders for equipment, the customer shall discuss the installations protection requirements with the Distributor.

The main circuit breaker shall be fitted with three phase inverse time over-current and inverse time earth fault and definite time sensitive earth fault protection that incorporates three phase tripping (lockout without reclose) as a minimum, and self-powered relays are not permitted. More complex protection arrangements may be required, in particular cases to meet acceptable protection performance criteria depending on the Customer's installation arrangement, the Distributor's system arrangement and the required protection performance levels. The central protection requirements of Clause 6.9.3.14 are to be considered for these supplies.

It is preferred that current transformers for over-current protection be located on the supply side of the main circuit breaker.

Protection settings and equipment shall be subject to the acceptance of the Distributor prior to commissioning. Any modification of the settings shall be subject to the acceptance of the Distributor.

In general, the Customer's primary phase fault protective devices for faults at the voltage level of the supply shall detect and clear the bolted short circuit faults not greater than 150 milliseconds at the fault level nominated at the point of supply. Any proposed operating time greater than 150 milliseconds shall be discussed with the Distributor at an early stage.

## 9.9 Insulation Co-ordination

The safety clearances, separation of live parts and insulation levels (impulse strength) shall be in accordance with AS 2067 and IEC 60071 Series or be type tested in accordance with AS 62271.200

## 9.10 Short Time Withstand Voltage and Current

### 9.10.1 Short Time Withstand Current

High voltage switchgear, conductors, associated equipment and earthing systems shall be capable of withstanding the maximum fault current which may be imposed on it for duration of at least one second and in some instances for three seconds. Actual fault currents and their maximum duration at any particular location on the Distributor's high voltage system will be made available upon request.

### 9.10.2 Short Time Withstand Voltage

Rapid Earth Fault Current Limiter (REFCL) installations

The 'Rapid Earth Fault Current Limiter' (REFCL) is a network protection device installed on the 22 kV distribution network to reduce the risk of fires caused by faulted powerlines by rapidly limiting the current that is released in a phase to ground earth fault only.

During a phase-ground fault, the neutral voltage may increase up to 13.9 kV leading to elevated phase to ground voltages on the two un-faulted phases. The un-faulted phases are required to withstand 24.2 kVrms continuous or as identified in the Electricity Distribution Code

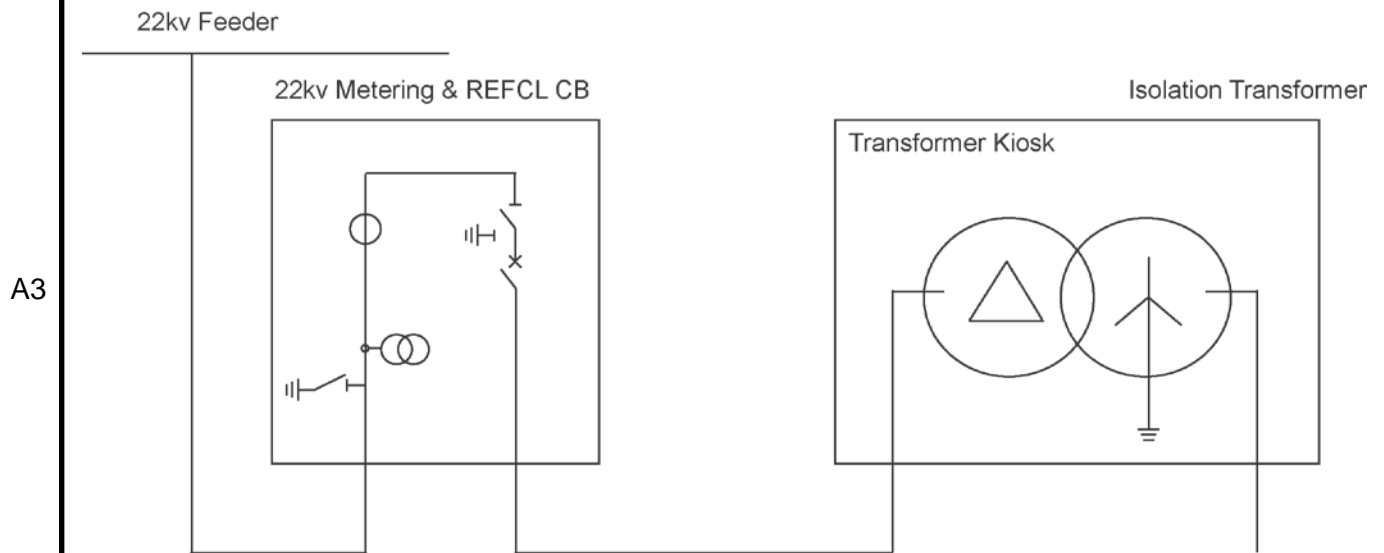

\* REFCL CB and metering to comply with clauses 9-7-2 and 9-13

### Figure 9.10.2-A Typical REFCL Isolation Transformer Installation

Voltage changes relate to phase-to-earth voltages only with phase-to-phase voltages remaining unaffected by REFCL operation. This means that, while HV customers are directly impacted by REFCL operation, customers supplied by LV are unaffected.

HV customers connected to a 22 kV REFCL protected network shall take all reasonable measures to mitigate or eliminate the risk of loss of damage to their equipment, premises or business as a result of exposure to the over voltages generated during REFCL operation. Given this impact on HV customers, the solutions which are currently utilised by HV customers in REFCL areas connecting to the distribution network may include:

- Installation of an Isolating Transformer
- Hardening of Primary Assets
- Conversion to Low Voltage
- Conversion to 66 kV

A2

Each Distribution Business may have specific requirements when connecting to a REFCL protected 22 kV distribution network. Contact the relevant Distribution Network operator prior to carrying out any work to discuss the specific requirements and available options for becoming a HV customer on any 22 kV distribution network.

#### 9.10.2.1 Isolating Transformer Solution

An isolating transformer may be installed at the HV customer's point of connection to eliminate the exposure of over voltages associated with REFCL operation as a result of phase to ground faults on the distribution supply network. As a consequence, any earth fault downstream of isolating transformer will NOT be detected or cleared by the REFCL equipment. A fault within the HV customer's 22 kV network (downstream of the isolation transformer) shall be detected and cleared by customer's own protection equipment. Additionally, no bare overhead conductor may be installed downstream from the isolating transformer to ensure any bushfire risk is mitigated.

#### 9.10.2.2 Primary Assets Hardening Solution

The second method which mitigates voltage stress on HV customer assets during REFCL operation is to identify primary assets within the customer installation which are not capable of being able to withstand an elevated voltage of 24.2 kVrms as identified in the

Electricity Distribution Code. Any assets or equipment which cannot meet these requirements shall be identified and replaced with equipment which can withstand an elevated voltage of 24.2 kVrms as identified in the Electricity Distribution Code

However, in order for the REFCL technology to work effectively, the network capacitance must be balanced across all phases. As such, it is the HV customer's responsibility to maintain the capacitive balance of their 22 kV network and it is the HV customer's responsibility to ensure any works shall not introduce any capacitive imbalance.

A fault within the HV customer's 22 kV network will be initially detected and cleared by the REFCL.

### 9.10.2.3 Conversion to Low Voltage

The third engineering solution available that eliminates voltage stress on HV customer assets during REFCL operation is for the HV customer to convert their HV primary assets to LV. Converting the installation to LV eliminates any impacts associated with REFCL operation.

### 9.10.2.4 Conversion to 66 kV

The fourth engineering solution available that prevents voltage stress on HV customer assets during REFCL operation is for the HV customer to convert their HV primary assets to 66 kV if applicable. Converting the installation to 66 kV eliminates any impacts associated with REFCL operation.

## 9.11 Earthing

### 9.11.1 General

The earthing system of the Customer's high voltage installation shall comply with the Electricity Safety (General) Regulations and these Rules.

Special attention should be paid to the management of "step and touch" potentials that may occur under earth fault conditions associated with any earthing system installed within a customer's installation. Particular attention should be paid to the separation of independent earthing systems and the proximity of earthed infrastructure such as metallic fences and buildings to earthing systems so as to avoid the possibility of hazardous step and touch potentials.

Earthed primary neutral windings are not permitted on any transformer of the nominal supply voltage. It is recommended that the Customer use Delta-Star transformers to comply with this requirement.

### 9.11.2 Size of Earthing Conductors

Earthing systems shall be designed to withstand the maximum system design fault current levels as specified in Clause 9.10.1 (Short Time Withstand Currents).

Conductors used within the customers installation for combined or separate earthing systems should have a minimum equivalent copper cross-sectional area as follows:

- Sub-transmission voltage protective earthing conductors: 66 kV – 120 mm<sup>2</sup>;
- High voltage protective earthing conductors:
  - 22 kV – 70 mm<sup>2</sup>,
  - 11 kV – 95 mm<sup>2</sup>;
  - 6.6 kV – 95 mm<sup>2</sup>
- Low voltage earthing conductors: refer to the Wiring Rules
- Equipotential bonding conductors: refer to the Wiring Rules

### 9.11.3 Earthing of Metering Equipment

The enclosure of the meter, metering transformers and any metal supporting structure/s shall be connected to the same earth grid as the Current Transformer and Voltage Transformer secondaries. The size of earthing conductors used for this purpose shall be in accordance with Clause 9.11.2 (Size of Earthing Conductors).

The cross sectional area of earthing conductors associated with metering secondary wiring but not associated with the installation earthing system shall be 4 mm<sup>2</sup>.

### 9.12 Distributor's Acceptance Requirements

**FAQ 020**

The Customer shall submit the following details for written acceptance prior to supply at high voltage being made available:

- Final single line diagram;
- Agreed maximum demand;
- Main circuit breaker specification;
- Protection settings for main circuit breaker;
- Compliance to the Distribution Code, including but not limited to a Systems study, Protection study and Earthing study;
- Copy of HV Metering VT and CT test certificates – refer to Clause 9.13.3 (Metering Transformers)

Before final connection is made the customer shall provide:

- The Electricity Suppliers Copy of the Prescribed Certificate of Electrical Safety;
- A copy of:
  - the site specific HV operating procedures; Refer to Clause 9.15.1 (Operating Procedures);
  - commissioning and test certificates as determined by the Customer and as prescribed by the Electricity Safety (General) Regulations which shall include trip tests on the incoming circuit breaker; Refer also to Clause 9.14 (Testing and Commissioning);
  - HV plant and equipment maintenance plan. Refer to Clause 9.15.3 (Maintenance);
- Contact details for Customer Authorised Electrical Operator and Operating Authority; Refer to Clause 9.15.2 (Trained Operators);
- Notification of metering work (NOMW)
- HV clearance to energise the installation.

### 9.13 Metering

The following high voltage metering requirements are applicable to single feeder high voltage installations (up to 66 kV) and are consistent with the National Electricity Rules, and the Electricity Customer Metering Code.

Other high voltage installations such as dual high voltage feeders, cogeneration installations and National Electricity Market Type 2 installations will require additional provisions.

### 9.13.1 General Requirements

Metering equipment shall be installed by the Metering Provider in accordance with the applicable requirements of Section 8 Low Voltage Metering and the following specifications. These include:

- A clear, illuminated (during normal business hours), paved and level space as specified in Clause 8.5 (Access), shall be provided in front of the metering position to allow access for meter reading and to accommodate test personnel and their equipment. A clear space 1.0 m deep is required in front of the meter position for safe access by Metering Provider and Distributor personnel.
- Access shall be direct (ground floor), or by stairs or lift. Ladder access is not acceptable.
- Metering equipment shall not be installed in unsuitable locations as described in Clause 8.6.4 (Unsuitable Metering Locations) and shall not be located within HV enclosures without prior approval from the Metering Coordinator where entry to the area requires the issue of an Electrical Access Authority.
- Acceptable to the Metering Coordinator to ensure the accessibility by other metering providers to meet their obligations under NER to rectify faults within reasonable timeframes.
- Metering equipment shall not be subjected to industrial contamination, extremes in temperature, or vandalism.
- Enclosures shall comply with the same requirements contained in Clause 8.4 (Metering Facilities).
- Metering enclosures shall be connected to the earth grid.
- The earthing design will consider step and touch potential around the meter panel location and as such a grading ring or extension of the earth grid may be required to ensure the safety of a person in its proximity.

### 9.13.2 Single Feeder Metering Requirements

#### 9.13.2.1 Meters Panels

The customer shall provide the meter panel/s and a suitable enclosure or surround for mounting a lift-off hinged panel on which to mount the metering equipment. For details see Figures 8.10-E and 8.10-F.

A clear space is required to provide access for mounting of metering equipment in accordance with Figures 8.11-A and 8.11-B. See Clause 8.6 (Location).

The minimum size meter panel for HV metering shall be 600 mm X 600 mm. In some cases, the Metering Coordinator may approve a maximum size 900 mm high x 600 mm wide meter panel.

Meter enclosures shall comply with Clause 8.4 (Metering Facilities) and 8.8.2 (Temperature Limits). The door on meter enclosures shall be labelled "Electricity Meters".

The Metering Provider will provide and install the wiring on the meter panel. The route length, size of cable and provision shall be discussed with the Metering Provider at the earliest opportunity possible and shall be installed by the customer.

As per the National Electricity Rules Chapter 7 design guidelines the metering point will be located close to the connection point, all metering circuits will be designed with a minimum amount of terminals and have sealing provisions for the Metering Provider seals.

A2



Meter panels will be for the exclusive use of metering provider equipment only and other equipment such as SCADA and protection devices will not be permitted to be installed within the same panel.

### 9.13.2.2 Freestanding Meter Enclosures

The Customer shall install and maintain:

- A metering enclosure (cubicle) complying with the requirements of Clauses 8.4 (Metering Facilities), and in particular designed, constructed and located to ensure the metering equipment does not exceed its temperature limits of specified operating range as per Clause 8.8.2.
- a formed all-weather roadway for vehicles to the meter position.

### 9.13.3 Metering Transformers

#### 9.13.3.1 Compliance

Voltage transformers shall comply with AS6004.2, “Voltage Transformers for Measurement and Protection”, and current transformers shall comply with AS 60044.1, “Current Transformers for Measurement and Protection”. Instruments tested to IEC61869 are acceptable with the Metering Coordinator approval but must also meet National Electricity Rules requirements.

The transformers should meet the performance requirements detailed in Table 9.13-1 any variation from this will require an exemption letter from the Metering Coordinator or Distributor.

The metering transformers shall be solely for metering purposes and are not to be used for other purposes such as protection or load monitoring as required by the National Electricity Rules Chapter 7.

Metering transformers mounted within the Customer’s high voltage switchgear shall only be acceptable if approved by the Metering Coordinator and Metering Provider and meet the sealing and accessibility requirements.

Test certificates from an accredited and registered laboratory shall be provided to the relevant Distributor and the Metering Coordinator and Metering Provider prior to installation. The test certificate shall show conclusive evidence that the transformers comply with the relevant Australian or IEC Standard specification.

The CT & VT information shall be written in legible English and be included on the test certificate:

- Serial No.
- Make
- Insulation ratings
- Burden rating
- Accuracy Class
- Specification
- Date of Test
- Laboratory or testing authority name and address where test occurred.
- Laboratory or testing authority NATA or ILAC accreditation.
- Name of person authorising the report.
- Reference to test methods (AS60044 or IEC61869)
- Proof of compliance with high voltage insulation requirements.

A2

- Test ratio(s), Burden(s), Currents, Voltages. Absolute values of Magnitude and Phase
- Determination of errors at each test point.
- A statement of measurement uncertainty on each report.

### 9.13.3.2 Test Facilities

The metering transformer test marshalling point (MMP) shall be provided behind the meter panel. For regulatory testing and verification purposes a test marshalling point shall be housed in the back of the meter panel enclosure and fitted with sealing or locking facilities in accordance with Clause 8.4.5.3 and labelled “Metering Marshalling Point” (MMP).

A VT, CT “Metering Terminal Point” (MTP) can be located within the switchboard enclosure or the field.

The metering marshalling point shall not be located within high voltage areas that require the issue of an Electrical Access Authority for entry. The metering terminal point (MTP) can be located within the HV area. Refer to Figure 9.13-A & 9.13-B for a typical wiring diagram test marshalling point.

The CT & VT name plate and NATA or ILAC test date is to be duplicated and displayed at the metering marshalling point in the metering enclosure.

Refer to Fig 9.13-B for typical metering marshalling point and metering terminal point definitions.

### 9.13.3.3 Mounted in Metal Clad Switchgear

The following requirements shall be met when metering transformers are located within the high voltage metal clad switchgear cubicle:

- The metering transformers shall be mounted within a HV metering chamber which is able to be placed under the Metering Provider seals. The HV CT’s, VT’s and chamber design shall be approved by the Metering Coordinator prior to purchase and construction.
- The layout of the transformer shall be such that identification of transformer polarities can be readily established, and such that there is ready access to the secondary terminals of all transformers for routine testing.
- No other devices apart from metering equipment (with the exception of anti-condensate heaters) shall be located within the HV metering chamber unless approved by the Responsible Officer.
- CTs to be installed with P1 facing the network and P2 facing the customer.
- The voltage transformers shall be permanently mounted within the HV metering chamber.
- Primary side fusing of VT's is acceptable. Discrimination is to be considered and labelling of the cover to state that 'Primary side VT fuses behind'. Spare fuses must be provided locally
- Where there are secondary terminals on metering transformers shall be accessible.
- The secondary windings of the Voltage Transformers shall be fused at the metering marshalling point (MMP) if the MMP is located within 3 route metres from the VT terminals. If the MMP is located greater than 3 route metres away from the VT terminals, then an additional set of fuses shall be installed at the metering terminal point (MTP) located adjacent to the VT CT chamber. HRC off set links to AS 60269 Series and equipped with 10 ampere fuse cartridges shall be installed within the MTP. Fuse sizes are to be as follows:

A3

- Metering Terminal Point (optional) – 10 A
- Metering Marshalling Point – 6 A
- Metering Panel Potential Fuse – 4 A
- The metering transformers shall be installed on the supply side of the Main Incoming Circuit Breaker. Provision for Customer switching or isolation prior to the metering transformers is not permitted.
- Secondary wiring from the current transformers metering terminal point shall be continuous. Continuous means not switched or run via other electrical equipment.
- Secondary wiring from the metering terminal point to the metering marshalling point shall be continuous. Continuous means not switched or run via other electrical equipment.
- Provision shall be made within the HV chamber for the application of safety earths to all high voltage conductors, to facilitate safe work on the metering transformers.
- The current and voltage transformers shall conform to the AEMO Metrology Procedure Part A.
- For 3 phase 3 wire metering the white phase secondary winding of the voltage transformer, which is earthed, shall not be fused. Refer Figure 9.13-A.

#### 9.13.3.3.1 Dual wound CT's and VT's

##### (a) CT's

Dual wound CT's shall have one core that is class 0.5, is compliant with the Rules stated burden requirements and is provided with a NATA or NATA Equivalent Test Report. The approval for the use of a 2nd core for other purposes is the responsibility of the Customers Metering Coordinator (MC) /Meter Provider (MP) and the obligation is on the MC to consult with AEMO, and provide evidence that the proposed "other purpose" will not interfere with the accuracy and performance of the NEM Metering under the NER. If the 2nd core is not used it shall shorted at the metering marshalling point. Provision of evidence of compliance early in the project phase will avoid unnecessary delays at connection time.

##### (b) VT's

In order to install dual wound VT's, a letter (on a business letterhead) from the customer's Metering Co-ordinator is required to be provided to the Distributor. The letter must provide written confirmation that the dual VT's comply with all the appropriate standards for acceptance of this equipment. Provision of the letter early in the project phase will avoid unnecessary delays at connection time.

#### 9.13.3.4 Supplied from an Underground Cable

##### (a) Located Outdoors

Metering transformers shall be installed within an enclosure mounted on a concrete pad supplied and installed by the Customer. Locking facilities suitable for padlocks (10 mm hasp) shall be provided for securing of the metering transformer enclosure.

##### (b) Located Indoors

Where metering transformers are located indoors and enclosed in a cage or cubicle, the requirements of Clause 9.13.3.1 (Compliance) shall apply in addition to the following.

The transformer enclosure shall be designed and installed in accordance with the requirements of AS 2067.

A3

A2

The Customer shall provide and install a minimum of a 40 mm conduit for the secondary wiring from the transformer enclosure to the metering position. The customer shall provide and install the secondary wiring from the VT's & CT's via the metering terminal point to the metering marshalling point in those conduits. The type and size of the secondary wiring shall be determined after consultation with the Metering Coordinator.

The enclosure shall also contain a suitable earthing bar between the CT's and VT's to allow for the earthing of secondary wiring circuits.

Sealing facilities shall be provided for securing of the metering transformer enclosure.

**Table 9.13-1 Metering Transformers Performance Guidelines**

DESCRIPTION	REQUIREMENT
<b>Voltage Transformers</b>	
ratio – 11 kV	Primary Voltage: $\sqrt{3}$ /110: $\sqrt{3}$
ratio – 22 kV	Primary Voltage: $\sqrt{3}$ /110: $\sqrt{3}$
Class	0.5
rated burden	4 mS for three phase units or 12 mS for single phase units
rated output	25 VA (min) per phase
voltage factor installed	1.9 / 8 h
insulation level – 11 kV	28 kV (PFWV), 95 kV (LIWV)
insulation level – 22 kV	50 kV (PFWV), 125 kV (LIWV)
<b>Current Transformers</b>	
Ratio	100 – 200 / 5 A or 200 – 400 / 5 A (ext 120%)
Class	0.5
rated burden	0.6 ohm
rated output	15 VA
rated short time current – 11 kV	18.4 kA / 3 s
rated short time current – 22 kV	13.1 kA / 3 s
insulation level – 11 kV	28 kV (PFWV), 95 kV (LIWV)
insulation level – 22 kV	50 kV (PFWV), 125 kV (LIWV)

**Notes:**

These guidelines only apply to 11/22 kV HV supply connections and further information should be obtained from the National Electricity Rules and the Metering Coordinator for 66 kV metering requirements.

A3

TYPICAL 3 PHASE 4 WIRE METERING WIRING DIAGRAM

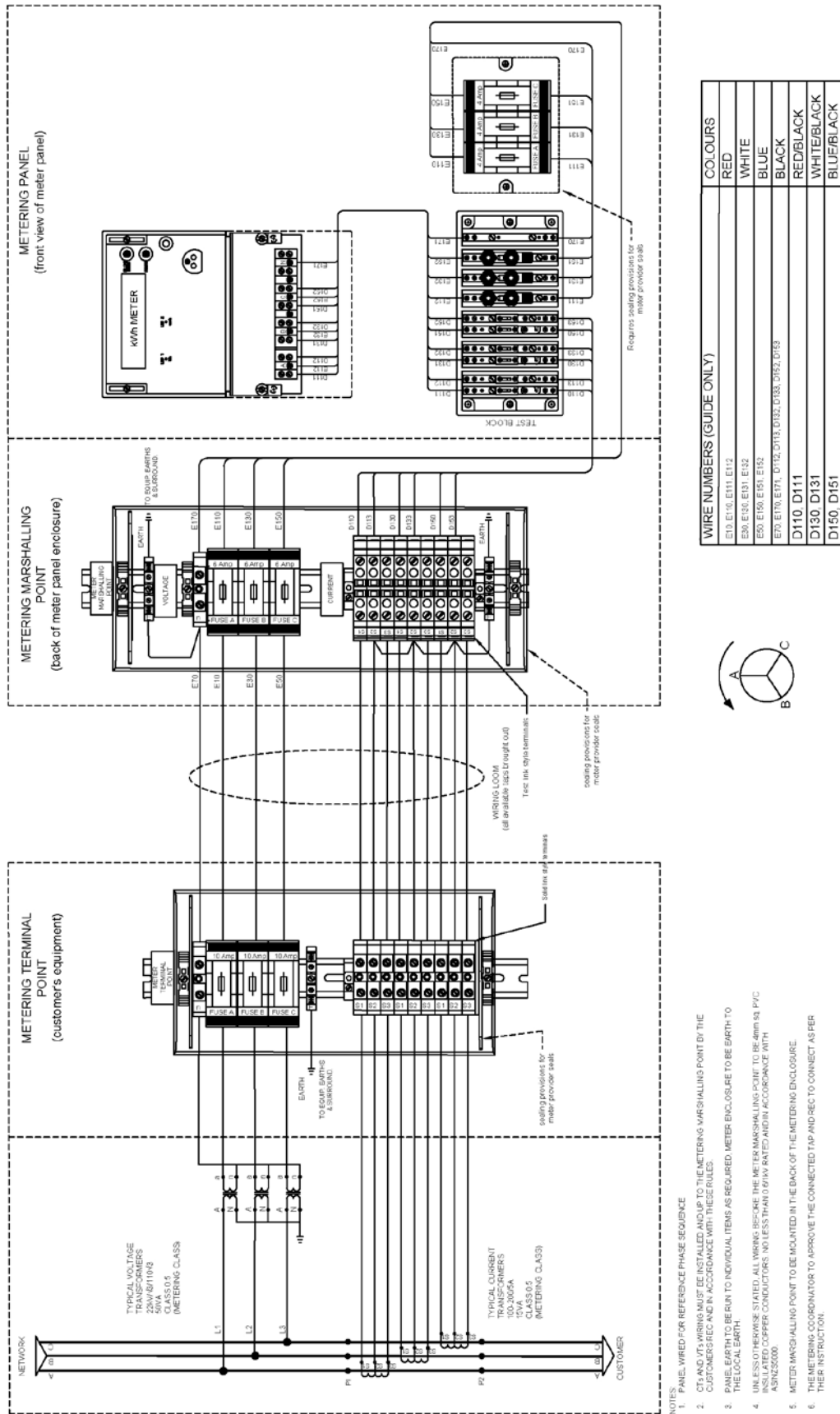

Figure 9.13-A Typical 3 Phase 4 Wire Metering Wiring Diagram

Note: For 3 Phase 3 wire arrangements contact the Metering Coordinator or refer to the VSIR website.

A2

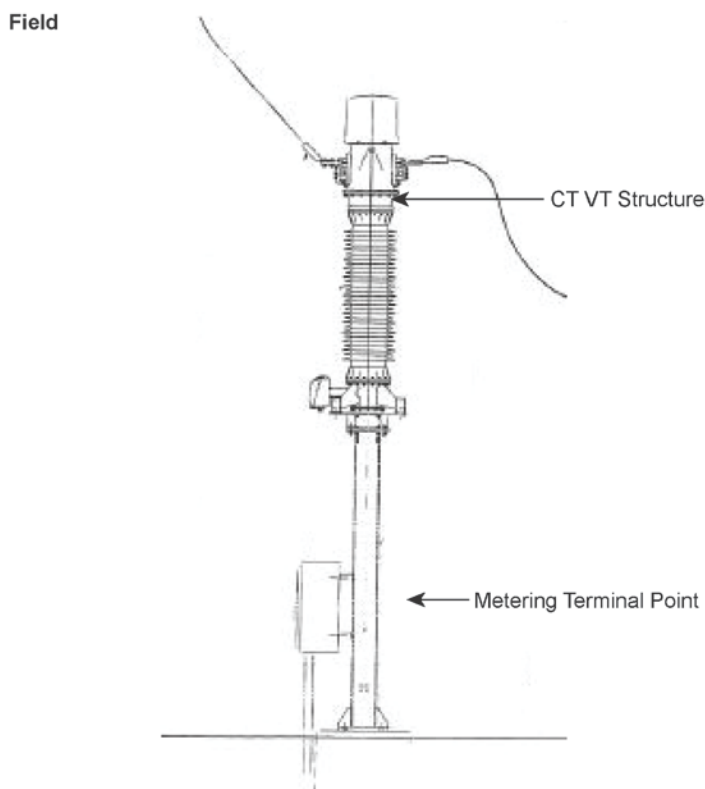
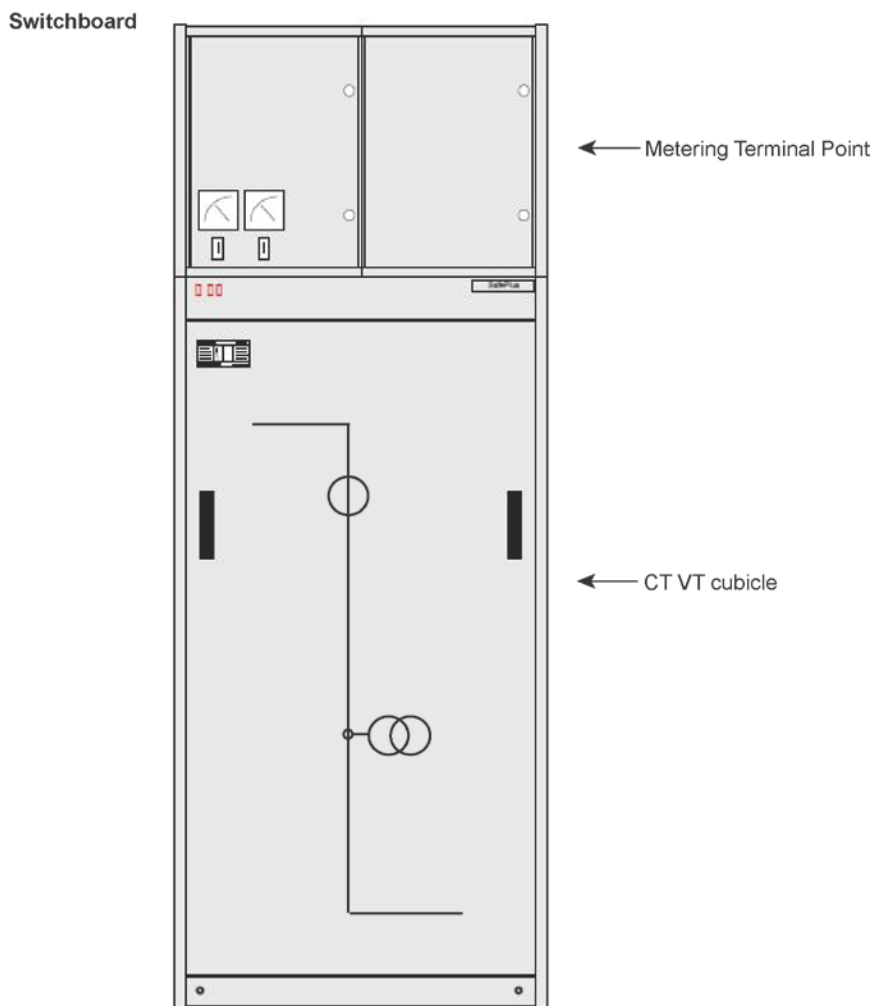

Figure 9.13-B Typical Metering Marshalling Point and Metering Terminal Point

## 9.14 Testing and Commissioning

The Electricity Safety Act requires that an inspection of new or altered high voltage equipment constituting prescribed work shall be performed in accordance with the regulations prior to connection of supply.

The high voltage equipment shall be tested on site in accordance with the requirements of the Wiring Rules and other relevant Australian Standards. These tests shall be performed by a competent testing organisation.

Test reports on all high voltage electrical equipment up to and including the main circuit breaker shall be available to the Distributor for approval prior to supply being made available.

The Distributor will not connect the whole or any part of the installation which in the opinion of the Distributor is unsatisfactory for connection to the supply system.

## 9.15 Customer's HV Installation Operation and Maintenance

### 9.15.1 Operating Procedures

The Electricity Safety Act requires HV customer's, to have, maintain and use up to date HV Operation Procedures and a trained operator.

The minimum operating procedures for customer's high voltage installations are set out in the Blue Book.

The Customer shall provide to the Distributor a copy of the Customer's high voltage operating procedures, prepared in accordance with the "Blue Book".

### 9.15.2 Trained Operators

The Customer shall ensure that high voltage switchgear, other than control switches designated for the use of plant operators, shall be operated only by persons selected and authorised by the Customer for that purpose.

The Customer shall ensure 24 hour availability of a suitably trained Authorised Electrical Operator to undertake switching operations on the high voltage assets as required by the Distributor for the purpose of inspection of HV metering transformers, load shedding, routine maintenance and emergency repair of the incoming high voltage supply cable.

The customer shall provide the Distributor with a current list of their Authorised Electrical Operators. This list shall be made available to the Distributor's operational control centre.

### 9.15.3 Maintenance

A Customer who takes supply at high voltage shall ensure that the high voltage installation is maintained in good order and any malfunction should not create a hazard or cause interference to the Distributor's supply system.

The Customer shall provide a written maintenance proposal for the Main Incoming Circuit Breaker before supply is made available.

A2

**This page intentionally blank**



# Appendix A

A3	<b>Appendix A - Contents</b>	<b>Page</b>
	Guidance for High Voltage Installations (Informative)	A1-1
	A1 Equipment and Standards	A1-3
	A1.1 Circuit Breakers	A1-3
	A1.2 Transformers	A1-3
	A1.3 Underground Cables	A1-4
	A1.4 High Voltage Motors	A1-4
	A1.5 Generators	A1-4
	A1.6 Protection and Control Equipment	A1-5
	A2 Installation	A1-6
	A2.1 Underground Cables	A1-6
	A2.2 Overhead Lines	A1-6
	A2.3 Substations	A1-6
	A2.4 Energy and Time Impulses	A1-6
	A2.5 Operating Equipment	A1-6
	A3 High Voltage Earthing	A1-6
	A3.1 Combined Earthing System	A1-7
	A3.2 Separate Earthing System	A1-7
	A3.3 Other Earthing Requirements	A1-7
A3	A3.4 High Voltage Embedded Generation	A1-8
	A3.4.1 Embedded Generation	A1-8

## A3 | **Guidance for High Voltage Installations (Informative)**

This appendix is to provide advice to customers of some of the issues to be considered when planning for and designing a high voltage installation.

Consideration of the following is considered good industry practice.

### A1 **Equipment and Standards**

Relevant Australian Standards for plant and equipment, including, but not limited to :-

- Switchgear and Controlgear AS 2067, AS 62271
- Transformers AS 2374
- Underground Cables AS 1026, AS 1429.1
- Motors and Generators AS 1359
- Current Transformers AS 60044
- Voltage Transformers AS 1243
- Protection Relays IEC 60255
- High Voltage Fuses AS 1033 or IEC 60282

#### A1.1 **Circuit Breakers**

- manufacturer;
- type number;
- class - indoor or outdoor;
- rated voltage;
- rated insulation level (lightning impulse withstand level);
- rated load current;
- rated short circuit breaking current;
- rated short circuit making current;
- minimum clearances in air - between phases and to earth;
- type of closing mechanism;
- whether trip free or fixed trip and with lock-out preventing closing;
- rated supply and /or pressure of closing mechanism; and
- details of any interlocking systems.

#### A1.2 **Transformers**

- manufacturer;
- rated voltages and tapping range;
- rating (kVA);
- lightning impulse withstand level;
- vector group symbol;
- insulating medium; and
- type of connections.

### **A1.3 Underground Cables**

- manufacturer;
- voltage designation;
- number of cores;
- conductor material, size and where applicable, size of reduced neutral conductor;
- type of insulation;
- construction details;
- type of terminations proposed;
- fault withstand rating of core and screen;
- proposed method of installation including mechanical protection; and
- screen earthing details for each end of any incoming supply cable.

### **A1.4 High Voltage Motors**

- manufacturer;
- type of motor and if an induction motor – cage or wound rotor;
- rated power (kW or hp);
- rated voltage;
- rated current;
- method of starting to be employed;
- starting torque in terms of the rated load torque and the maximum starting current
- which may be taken from the supply with the starting apparatus in the circuit;
- if thyristor control equipment is proposed, details relating to the harmonic current
- generation is required; and
- frequency of starting.

### **A1.5 Generators**

- manufacturer;
- type of generator;
- rated output;
- rated voltage;
- rated current;
- synchronous, transient and sub transient reactance. (if generator is connected to the supply system through a solid state inverter indicate three phase short circuit current at output side of inverter);
- details of generator neutral earthing;
- type of excitation;
- voltage regulation; and
- speed regulation.

## A1.6 Protection and Control Equipment

- Current Transformers:
  - rated transformation ratios;
  - primary current rating;
  - secondary current rating;
  - type classification;
  - accuracy classification;
  - accuracy limit factor;
  - rated burden;
  - rated secondary reference voltage;
  - manufacturer serial number(s);
  - secondary winding configuration; and
  - applicable standard if not to AS 60044.
- Voltage Transformers:
  - rated transformation ratios;
  - rated secondary voltage;
  - type classification;
  - accuracy classification;
  - rated burden;
  - rated output;
  - rated voltage factor and duration;
  - manufacturer serial number(s);
  - secondary winding configuration;
  - primary connections; and
  - applicable standard if not to AS 1243.
- Protection Relays:
  - manufacturer;
  - type; and
  - settings.
- High voltage fuses:
  - type;
  - rated current or reference current; and
- Battery and battery charger details.

**A2 Installation****A2.1 Underground Cables**

A3 | The high voltage underground cables shall be installed in accordance with the Electricity Safety (General) Regulations.

After installation and before activation, the cables should be tested in accordance with the relevant industry standards and cleared for service.

A3 | In accordance with the Electricity Safety (General) Regulations a detailed drawing recording the route, depth of wiring system and other relevant information should be produced by the customer. This drawing should be available for the use of all persons concerned with future ground openings on the property.

**A2.2 Overhead Lines**

A3 | Overhead lines shall be designed and constructed in accordance with the Electricity Safety (General) Regulations.

**A2.3 Substations**

All apparatus should be clearly and uniquely labelled to ensure correct identification by operating and maintenance personnel.

The design of the substation should provide suitable safety clearances and earthing points to allow safe access for maintenance and inspection without the need to de-energise the entire installation. This should be in accordance with the Code of Practice on Electrical Safety for Work on or Near High Voltage Electrical Apparatus (the Blue Book).

**A2.4 Energy and Time Impulses**

If a Customer wishes to monitor and control energy management equipment, energy and time impulses are available on request from the Metering Provider. The cost of this will be in addition to other costs incurred. The form of pulses provided will be at the discretion of the Metering Provider.

The Distributor will bear no liability under any circumstances for possible malfunctions of the pulsing equipment.

**A2.5 Operating Equipment**

High Voltage apparatus such as operating sticks, safety earths, gloves and insulating mats shall be made available by the Customer for use by their HV operators in accordance with the Customer's high voltage operating procedure.

## A3 High Voltage Earthing

### A3.1 Combined Earthing System

The preferred earthing system is the “combined earthing system”. A combined earthing system is one where the high voltage and low voltage equipment is earthed to a common terminal bar.

A combined earthing system shall be installed to the requirements of the Act and Regulations.

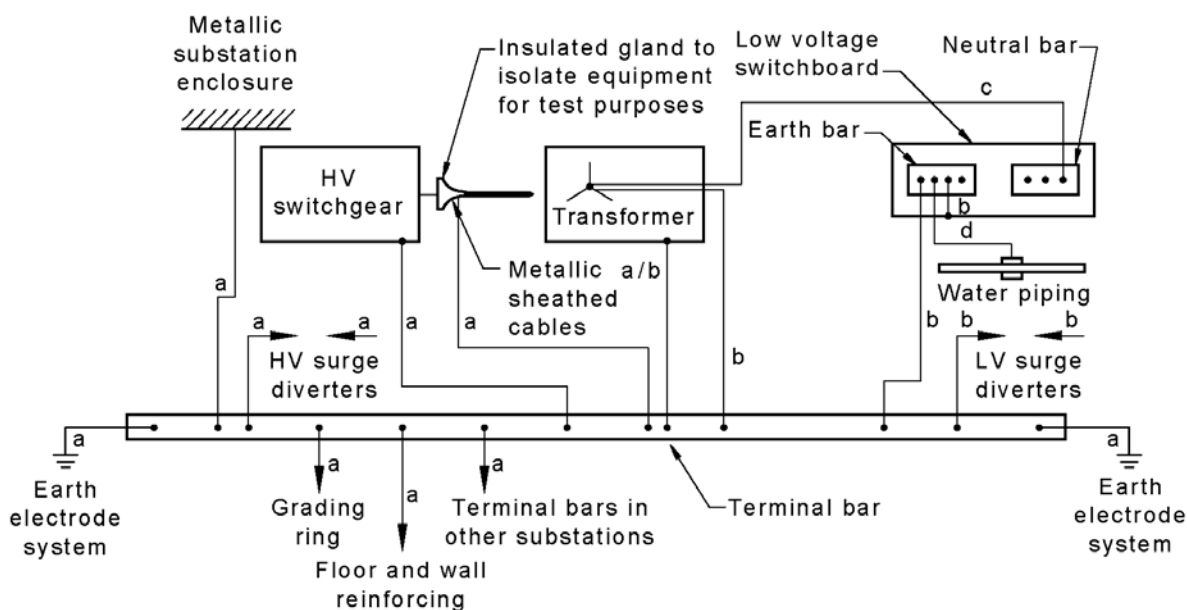

#### LEGEND:

- a = Conductor sized to HV fault current and in accordance with AS2067
- b = Conductor sized to LV fault current and in accordance with AS2067
- c = Neutral conductor sized in accordance with AS/NZS 3000
- d = Conductor sized in accordance with AS/NZS 3000

NOTE: All the earth connections shown above may not be required in a particular situation.

**Fig A3.1 - A Guide to the Combined Earthing System**

### A3.2 Separate Earthing System

A ‘separate earthing system’ is permitted, where appropriate, however, there is particular safety hazards to manage with separate earthing systems. If a separate earthing system is installed, then the customer should advise the Distributor and provide details of the installation.

### A3.3 Other Earthing Requirements

Generally, metallic substation fences, doors or enclosures should be connected to the earthing system and a grading ring should be installed around the substation enclosure in accordance with AS 2067.

Reinforcing in the substation floor or walls should be connected to the common earth terminal bar.

A3

**A4**

**High Voltage Embedded Generation**

**A4.1**

**Embedded Generation**

Embedded HV generation requires a Distributor contract. This contract will establish the appropriate requirements. Refer to Clause 6.9.7 for further information